

User Manual – LDD-1321

**meerstetter
engineering** 

 Member of Berndorf Group



Developed, assembled, and tested in Switzerland

Index

1	Introduction.....	4
1.1	Important Documents	4
1.2	How to Contact Support.....	4
2	Basic Functions	5
2.1	The Status Bar of Service Software	5
2.2	Remote Control Options	8
2.3	Firmware Updates	9
3	Operating the Current Driver	10
3.1	Theory of Operation.....	10
3.2	Driver Settings.....	13
4	Temperature/Light Measurement and Analog Interfaces	16
4.1	Temperature Measurement	16
4.2	Light Measurement.....	17
4.3	Voltage Input	17
5	Data Logging	18
5.1	Monitor Data Logger.....	18
6	External Hardware	19
6.1	GPIO Control Signals	19
6.2	Cooling fans	20
7	Special Functions	24
7.1	Parameter Handling.....	24
8	Troubleshooting and Errors	26
8.1	Quick Reference.....	26
8.2	Error Numbers, Instances and Parameters.....	27
A	Change History.....	31

Meerstetter Engineering GmbH

Schulhausgasse 12

CH-3113 Rubigen

Switzerland

Phone: +41 31 529 21 00

Email: contact@meerstetter.ch

Meerstetter Engineering GmbH (ME) reserves the right to make changes without further notice to the product described herein. Information furnished by ME is believed to be accurate and reliable. However typical parameters can vary depending on the application and actual performance may vary over time. All operating parameters must be validated by the customer under actual application conditions.

LDD-1321 User Manual 5292A

LDD-1321 Firmware Version v1.00

Release date: 14 June 2023

1 Introduction

This manual covers the functionality of the LDD-1321 digital (laser) diode driver.

Most of the explanations in this document assume that you use the “LDD-1321 Service Software”, but all the operations can also be done by your own application if you implement similar functionality along our communication protocol. Most of the commands are documented in our communication protocol documents.

If you cannot find the feature or setting you need, please do not hesitate to contact our support. We do also provide customized firmware solutions.

1.1 Important Documents

- [Datasheets](#)
 - Technical specifications
 - Hardware configurations
 - Ordering information
- [LDD-1321 Communication Protocol](#)
 - Protocol specification
 - Commands, Parameters
 - Example Applications and [APIs](#)
- [Temperature Sensor Suggestions](#)
 - Description, part numbers and distributors for NTC sensors
- [Application Notes](#)
 - Additional Information about various usage scenarios of our devices

1.2 How to Contact Support

For optimal technical assistance we need the following information:

- Configuration file, exported while the error is present
 - Click “Export Config” in the footer.
- Monitor History
 - Click “Maintenance” tab” → “Monitor Data Logger” → activate checkbox “Export all Monitor Values to CSV File (Debug)” → “Export Logged Monitor Data to CSV File”
- A picture showing your system, the controller and the sensor leads.
- Datasheets of your diode, Peltier element, power supply and any other important parts involved in your setup.

You can also use the [TeamViewer software from our website](#) for a remote-control session. As soon as you start the tool we will be able to recognize you, but please make sure to call or write us beforehand to make sure someone is available.

2 Basic Functions

2.1 The Status Bar of Service Software

The bottom row of the software is always visible and shows the following information:

- Connection status
- Device status
 - Ready: normal standby status (no errors). Output stage disabled.
 - Run: normal operating status (no errors). Output stage enabled.
 - Error: an error occurred. Output stage disabled.
 - Bootloader: the firmware is being updated.
- Operating parameters
 - Output current and voltage.

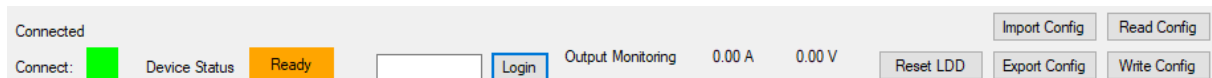

Figure 1. Status bar in the bottom row of the Service Software.

2.1.1 Status LEDs and Service Software Status

The device features two status LEDs. In normal operation, the green LED is blinking.

In the case of any error occurring, the device enters an error status, and the red LED is lit. Power circuitry (output stage) is immediately deactivated to ensure safety. Control, monitoring, and communication circuitry remains active. In case of software / configuration errors (i.e. not hardware faults), parameters can be reconfigured on the fly. The device needs to be software-reset or power-cycled to clear the error status.

Table 1. Status LED description.

Green LED	Red LED	Signification
Blinking slowly (~1 Hz)	-	“Ready” status (no errors). Output stage disabled
Blinking fast (~2Hz)	-	“Run” status (no errors). Output stage active
-	Static on	“Error” status. Output stage disabled
Static on	Static on	“Bootloader” status

When the Service Software is connected to a device, its status is displayed in the bottom of the software window.

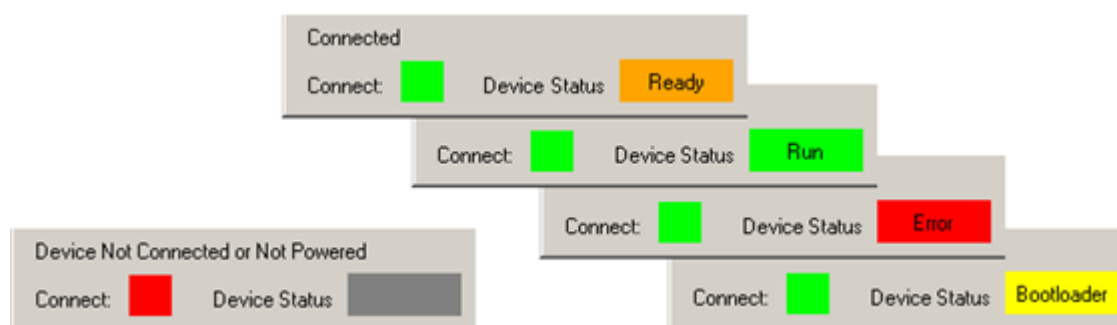

Figure 2. Service Software color codes for connection and device status.

Error Status:

If the device enters the error status, please go to the “Monitor” tab, there you can find the error number and description on the right side of the window.

Alternatively, you can find a list of all errors at the end of this User Manual.

2.1.2 Writing and Reading Device Parameters

Changed parameters are saved to the controller by clicking “Write Config” in the footer. Multiple parameter fields can be written at once. Be aware that also fields in tabs which are not currently displayed are written to the controller.

Parameters are read automatically when a connection to the controller is established.

2.1.3 Importing and Exporting .ini Configuration Files with the Service Software

Device configuration sets can be exported as backup or for support purposes. They are specific to each unit as they contain calibration data.

- Export

- To save a configuration file on the PC, click on “Export Config” in the bottom right corner of the Service Software.
- All actual values are also stored. The values are useful for support and analysis.
- Import
 - To load a configuration file from the PC, click on “Import Config” in the Service Software.
 - By default, calibration data is only imported when the serial number in the configuration file matches the connected device's serial number (this option can be disabled in the relevant tabs at the bottom).

2.2 Remote Control Options

This is an overview of the different remote-control options for the device. It's possible to configure, control and monitor the device using any software which can communicate over an appropriate interface. In the corresponding communication protocol document a list of the software options available from us can be found.

Generally, all parameters available in the Service Software can be read and written by other means using the communication protocol.

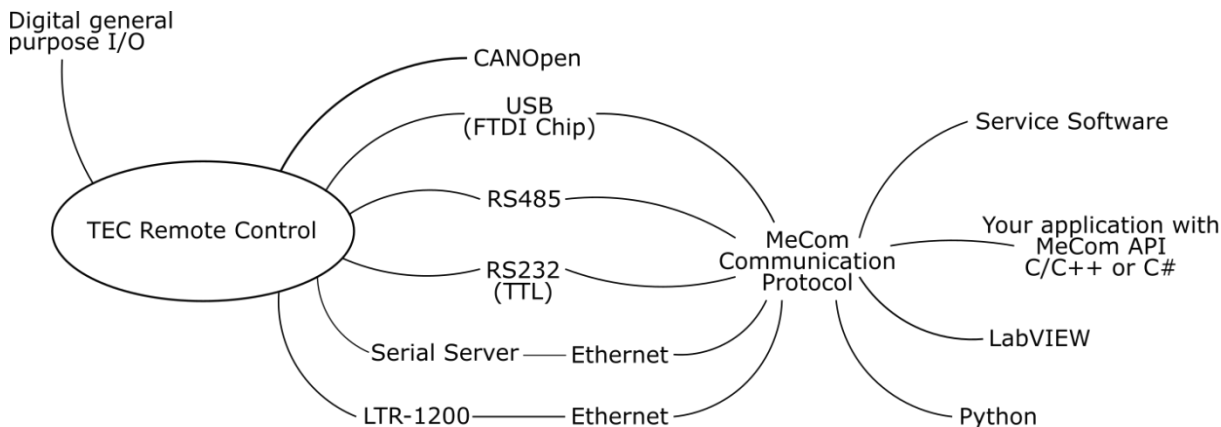

Figure 3. Remote control options (TEC shown for illustrative purpose, check datasheet for actually available interfaces).

2.2.1 Serial Communication

Serial communication is used to send data from a host to the device and receive data from it, respectively. The following physical interfaces are supported:

- USB
- RS485 (check out our [TEC Application Note - RS485 Interface](#), valid for other devices too)
- RS232 TTL¹

Communication using the Service Software and RS485 is only possible using a USB–RS485 adapter or an Ethernet serial server, since the Service Software only connects to FTDI² chips or TCP port 50'000.

2.2.1.1 Addressing specific devices

Assign a unique “Device Address” to the device if multiple devices are operated on the same bus. The “Device Address” can be set on the “Operation” tab when the Service Software has already connected to the device. You can then tell the Service Software to use a specific device address to communicate. To do this, open the “Maintenance” tab and look for “Service Communication Settings”. For more application arguments, check our communication protocol document. All devices have a 1-unit load receiver input impedance, allowing up to 32 transceivers on the RS-485 bus.

2.2.2 Ethernet Communication

It's possible to use a standard Serial Server to connect our devices to an Ethernet interface. We have tested devices from Lantronix (e.g. XPort, UDS1100) and Moxa (e.g. NPort 5130). Please check [TEC Application Note - RS485 Interface](#), valid for other devices too.

¹ Availability dependent on device.

² One option is the [USB RS485 converter cable from FTDI Chip](#), available in different lengths.

2.3 Firmware Updates

You can [download the firmware \(contained in the software package\)](#) from our website and update your devices using the Service Software.

The Service Software and the Firmware are strongly related. Only when a Service Software and a Firmware with a matching Version Number are used the full functionality can be guaranteed. However, it is usually possible to connect to a device with an old Firmware with a new Service Software and vice-versa. Functionality will be limited, but firmware updates are possible.

Matching version numbers: All our published software has a version number similar to this: "vX.YZ". It is important that at least X and Y is matching. Z can be different.

Follow these steps to update devices:

- Read the software release notes
- Backup the current configuration. This is important because it is possible that the current configuration will be lost during the update.
- In the tab "Maintenance" locate "Device Boot Loader".
- If the *.msi* installation package has been used, the correct hex file is already selected, otherwise
 - click browse and choose the new *.hex* file.
- Click "Update"
- The device will reboot once the update completes.
- You can check the firmware version in the tab "Monitor".
- Re-import the before exported *.ini* file (if necessary).
- Fill missing parameter values into new parameter fields (if applicable).

3 Operating the Current Driver

3.1 Theory of Operation

This device features a linear-mode laser diode driver, which uses a transistor (pictured as a current source) to regulate the current in the laser. The anode power supply is integrated in the device. This topology requires to consider the power dissipated on the current sink, as the portion of the voltage that does not fall on the load will fall on it.

To enable simple and safe use, this device automatically shuts down if the safe operating area of the current sink is not respected.

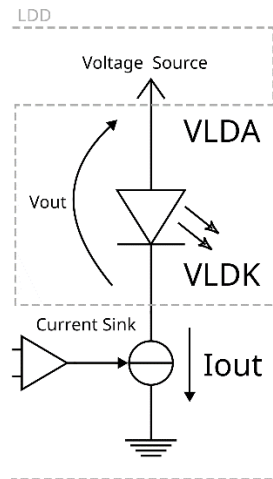

Figure 4. Topology of the device.

The anode voltage is set by the firmware depending on the laser characteristics input by the user, and the current limit (Max Nominal Current).

Anode Voltage Settings		
	Actual	New
Supply Enable	Static OFF	<input type="button" value="v"/>
Laser Forward Voltage	1	<input type="text"/>
Laser Diff. Resistance	0.2	<input type="text"/>

Figure 5. Anode Voltage Settings (values not relevant).

Output Stage Limits		
	Actual	New
Max Nominal Current [A]	?	<input type="text"/>
Min Nominal Current [A]	?	<input type="text"/>
Current Error Threshold [A]	?	<input type="text"/>
Voltage Error Threshold [V]	?	<input type="text"/>

Figure 6. Output Stage Limits.

The anode voltage is set according to the following formula:

$$V_{LDA} = V_f + \left((R_{diff} + R_{internal}) \cdot I_{lim} \right) + 1$$

Where $R_{internal} = 50 \text{ m}\Omega$, V_f = Laser Forward Voltage, R_{diff} = Laser Diff. Resistance, I_{lim} = Max Nominal Current.

This is activated by setting the Supply Enable to Static ON, and the effective anode voltage can then be seen in the monitor tab.

Due to the topology of the LDD, part of this voltage will fall on the load, and part of it on the current regulating transistor.

This transistor is subject to a safe operating area (SOA) as pictured in the datasheet. Violating this limit will cause the device to error out and shut down its output, to prevent damage.

To determine if the LDD will be able to drive your load, you can use the following steps:

1. Determine the characteristics of your load. As examples, we will take a laser diode and a 4Ω resistor.

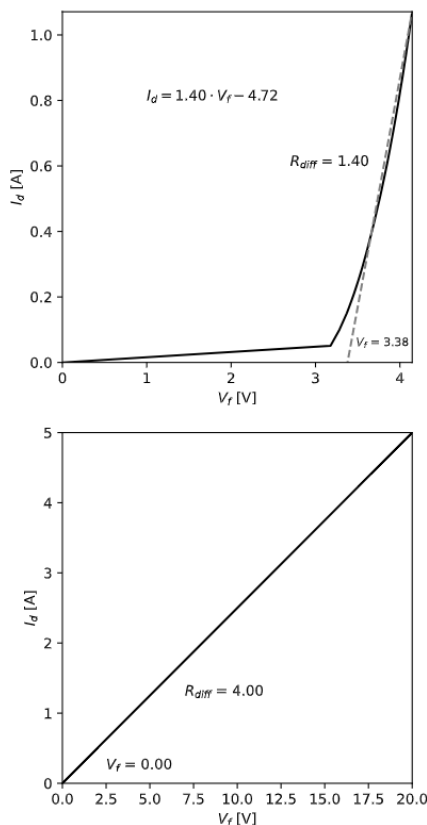

Figure 7. Example characteristic curves.

The laser diode IV-curve is provided in its datasheet. Defining a differential resistance and forward voltage means making a simple linear model of this curve.

As a current limit, we will use 1.2 A for the laser, as specified in its datasheet, and 1.5A for the resistor.

Taking 2 points on the line, these characteristics are obtained: $R_{diff} = 1.4$ A, $V_f = 3.38$ V.

The case of the resistor is simpler: the forward voltage is zero, and the differential resistance is its resistance, 4.

2. Determine the V_{LDA} .

For the first load, the LDD will set the nominal anode voltage to 6.12 V, for the second load it will set it at 7.08V.

3. Calculate the load line.

Knowing the anode voltage and knowing how much voltage falls on the load at every level of current, we can calculate the relation between the cathode voltage (which is the voltage that will fall on the transistor) and the load current.

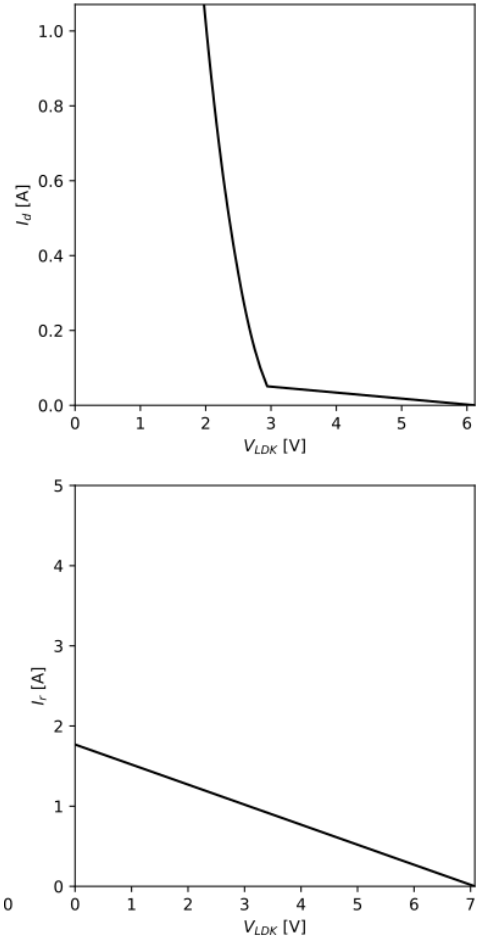

Figure 8. Load lines.

4. Draw the load line on the SOA chart.

By transferring this line on the SOA chart (to build in margin, I will take the one at the temperature limit of the device), we can now see if we will be able to operate the load in all the operating points that are of interest.

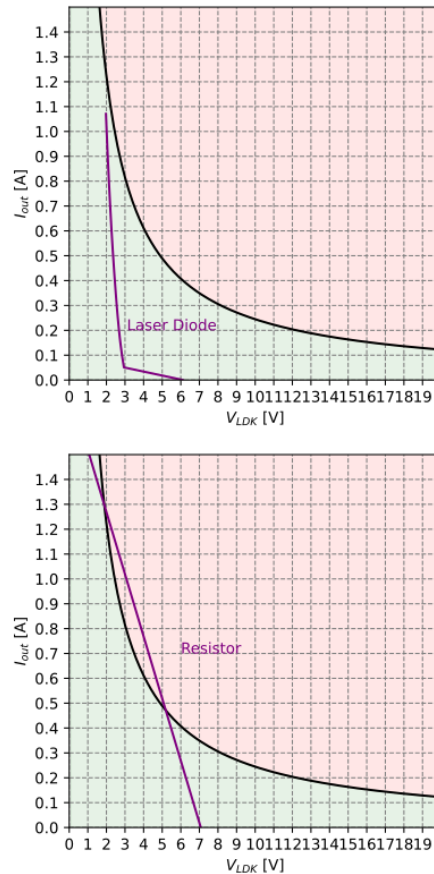

Figure 9. The load lines superimposed on the SOA chart.

The laser diode will be in the safe operating area at all its operating points.

The resistor load line, however, crosses into the unsafe area for middle values. This means that if such a resistor is taken as a test load and driven at currents above ~ 0.4 A, the device will error out.

Note that this process does not consider the device temperature limit: if adequate cooling is not provided, the device can still shut down due to overheating, even if the transistor is still within its safe operating area. To increase the efficiency, it's important to not use an excessive V_{LDA} even if the load line would be in the operating area, therefore it's useful to set the maximum current to a current that is actually needed, and not the maximum current supported by the laser.

3.2 Driver Settings

3.2.1 Operation Settings

The "Operation" tab features the settings that control the current driver.

LDD

Input Source Selection		Actual	New
Output Enable	?		▼
Nominal Output Current*	?		▼
Nominal Output Current Values			
Set Current [A]	?		
Current Control Settings			
Slope Limit [A/s]	?		
Anode Voltage Settings			
Supply Enable	?		▼
Laser Forward Voltage	?		
Laser Diff. Resistance	?		
Output Stage Limits			
Max. Nominal Current [A]	?		
Min. Nominal Current [A]	?		
Current Error Threshold [A]	?		
Voltage Error Threshold [V]	?		

Figure 10. LDD settings.

The Output Enable setting sets the behavior for turning the current on and off. The available settings are:

Table 2. Output Enable options.

Value	Effect
Static ON	Output on.
Static OFF	Output off.
Volatile	Output enable controlled by volatile parameter (see communication protocol document).
GPIO	Output enable controlled by GPIO.

Note that in all cases, the anode supply must be enabled for the driver to be able to drive a current. See 3.1 Theory of Operation.

“Nominal Output Current” sets the source for the nominal current, this can be “Set Current” (the non-volatile parameter shown in the same tab) or volatile (a volatile parameter, see communication protocol document).

“Set Current [A]” is the non-volatile parameter for the nominal current.

The “Slope Limit” acts on the internal nominal current, whose rate of change can be limited. This will cause the driver to ramp the current when turning on or after modifying the set current.

Setting this to a high level means the current rise will be as fast as the analog bandwidth of the driver allows it to be and can lead to worse control during transients, especially on inductive loads.

The “Anode Voltage Settings” provide the controller with a model of the load, used to set a V_{LDA} appropriate for the load. “Supply Enable” turns the anode power supply on and off. See 3.1 Theory of Operation for information on the “Laser Forward Voltage” and “Laser Diff. Resistance” settings.

The “Output Stage Limits” settings define the limits and error thresholds for the current and voltage (on the load).

“Max Nominal Current [A]” also contributes to setting the anode voltage.

“Min Nominal Current [A]” will limit the nominal current and can be set down to zero, but the effective minimum current is determined by the LDD’s characteristics (see datasheet).

The error thresholds will cause an error and a shutdown of the output when crossed, they should therefore be set a bit higher than the nominal values, but low enough to protect the load against incorrect settings. The turn-off is subject to a reaction time, so that for a short time e.g. the current can be above the threshold before being turned off, depending on the event that causes the threshold crossing.

3.2.2 Calibration Settings

The tab “Advanced” > “LDD” features calibration settings. Some of these can be used by the user for

4 Temperature/Light Measurement and Analog Interfaces

4.1 Temperature Measurement

This input can accommodate NTC sensors.

Error thresholds to protect your load against overheating are available in the “External Temperature” tab. They can be activated via the setting in the “External Temperature Errors Enable” box. The error limits can be set for each input in the “External Temperature Error Limits” box.

Figure 11. External Temperature Error Settings.

If the “ADC Limit Errors” are enabled, an error will be thrown if the NTC sensor has reached a resistance value that is at the edge of the measurable range of the controller. It offers a selection of different threshold detections, one for only the upper value, another only for the lower value and one for both.

Figure 12. External Temperature Errors Enable for ADC Limit Errors.

If the “Temperature Limit Errors” are enabled, the crossing of the thresholds set in “External Temperature Error Limits” will be detected and cause an error. It offers a selection of different threshold detections, one for only the upper value, another only for the lower value and one is for both.

Figure 13. External Temperature Errors Enable for Temperature Limit Errors.

The “External Temperature Measurement Settings” allow an additional user calibration for each input.

Figure 14. External Temperature Measurement Settings.

The “External Temperature Measurement Limits” are calculated values showing the range of measurable resistance of the input. The corresponding maximum and minimum temperatures are calculated for each temperature input using the sensor characteristic found in tab “Advanced” > “External Temperature Measurement”, in “External NTC Sensor Characteristics”.

Monitor	Operation	Light Power Control	External Temperature	Analog Interfaces	Maintenance	Advanced
External Temperature Measurement		LDD Measurement	Analog Interfaces	GPIO	Temperature Correction	Misc
External Temperature ADC Calibration 1			External Temperature ADC Calibration 2			
		Actual	New		Actual	New
	Offset	0	<input type="text"/>		0	<input type="text"/>
	Gain	1	<input type="text"/>		1	<input type="text"/>
External NTC Sensor Characteristics 1			External NTC Sensor Characteristics 2			
		Actual	New		Actual	New
Upper Point	Temperature [°C]	60	<input type="text"/>	Upper Point	Temperature [°C]	60
	Resistance [Ω]	2488	<input type="text"/>		Resistance [Ω]	2488
Middle Point	Temperature [°C]	25	<input type="text"/>	Middle Point	Temperature [°C]	25
	Resistance [Ω]	10000	<input type="text"/>		Resistance [Ω]	10000
Lower Point	Temperature [°C]	0	<input type="text"/>	Lower Point	Temperature [°C]	0
	Resistance [Ω]	32650	<input type="text"/>		Resistance [Ω]	32650

Figure 15. External NTC Sensor Characteristics settings.

4.2 Light Measurement

The optional light measurement input offers the possibility to observe the photodiode current via a parameter shown on the Monitor tab (“Photodiode Input [mA]”). In absence of the feature the value will always be NA.

Through the parameter “LP System Scale” LP_{gain} , the conversion factor to translate the photodiode current I_{ph} into an emitted light power P_{light} , can be defined. This parameter depends on the photodiode and the optical coupling of the system. You can set this arbitrarily in the absence of an absolute reference measurement.

$$P_{light} = \frac{I_{ph}}{LP_{gain}}$$

The above formula shows the relationship between the emitted light power and the photodiode current. The scale setting is in the “Advanced” > “Analog Interfaces” tab.

The tab “Advanced” > “Analog Interfaces” also features the “Photodiode Rs” setting. Note that “Photodiode Rs” depends on the hardware configuration and does not need to be modified by the end user.

The resistance values correspond to each configuration:

Table 3. Photodiode input configurations.

Photodiode Rs [Ω]	Configuration [mA]
5600	0.5
2700	1
1300	2
680	4

These settings have no effect on devices that do not have this feature.

4.3 Voltage Input

The analog voltage input is displayed in the “Monitor” tab.

In “Advanced” > “Analog Interfaces” you can set a user calibration through offset and gain parameters.

5 Data Logging

5.1 Monitor Data Logger

For external plotting and data analysis, logged data can be exported to a .csv file, in the “Maintenance” tab in the box “Monitor Data Logger”.

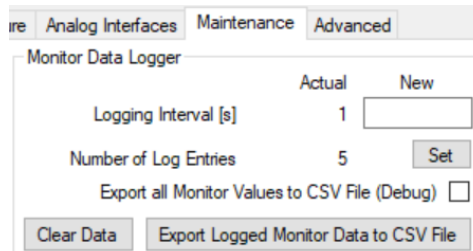

The screenshot shows a software interface with three tabs: "Analog Interfaces", "Maintenance", and "Advanced". The "Maintenance" tab is active. Inside this tab, there is a section titled "Monitor Data Logger". It contains the following elements:

- A table with two columns: "Actual" and "New".
- A row for "Logging Interval [s]" with the value "1" in the "Actual" column and an empty input field in the "New" column.
- A row for "Number of Log Entries" with the value "5" in the "Actual" column and a "Set" button in the "New" column.
- A checkbox labeled "Export all Monitor Values to CSV File (Debug)" which is currently unchecked.
- Two buttons at the bottom: "Clear Data" and "Export Logged Monitor Data to CSV File".

Figure 16. Monitor Data Logger.

- Each log entry is time stamped.
- At relaunch of the software the log is erased, and the log interval is set to the smallest value of 1 s.
- The general data logging duration is not limited. It depends on the available RAM on the PC and the logging interval.
- For critical long-term monitoring we recommend exporting the log regularly and to relaunch the Service Software occasionally (e.g. every couple of days).
- The exported file of the logged data contains the value of various monitor parameters such as the output current.
- Select “Export All Monitor Values to CSV File (Debug)” to export more values, which can be useful if you send the file to Meerstetter for diagnosis.

6 External Hardware

6.1 GPIO Control Signals

The GPIO control signals can be used as general purpose I/O (GPIO) or for predefined functions. The functions described in Table 4 can be independently assigned to the GPIO signals in the “Advanced” > “GPIO” > “GPIO General” tab. Many functions are separately available as several channels. For these functions, the channel can be chosen as well. For the functions which are not available in multiple instances this setting has no effect.

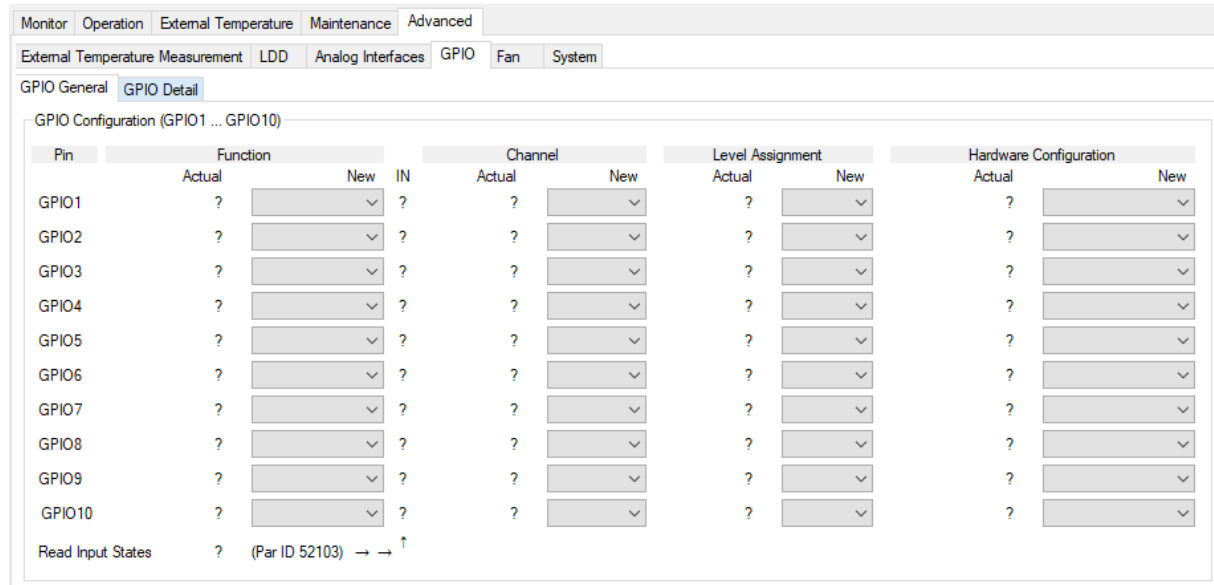

Figure 17. GPIO General settings.

Table 4. GPIO functions.

Function Name	Description
No Function	The GPIOx has no function. The pin is at high impedance state.
Signal Control	The GPIOx signal is used as digital I/O, controlled by the communication interface. Refer to the communication protocol document for more information.
LDD OK	The GPIOx signal is logic 1 if the device is in the “Ready” or “Run” status.
HW Enable	The GPIOx signal is used as input to enable the output of the driver. In the “Operation” tab select “GPIO” as “Output Enable” source. If the signal is logic 1, the driver output is enabled.
Fan PWM	The GPIOx signal is used as PWM output for the Fan Control feature. Only selectable for GPIO5 and GPIO6 (see chapter 6.2 Cooling fans). For this function, the "Hardware Configuration" is usually set to "Out PushPull" to properly drive the PWM input of the fan.
Fan Tacho	The GPIOx signal is used as frequency input for the fan control feature (see chapter 6.2 Cooling fans). For this function, the "Hardware Configuration" is usually set to "IN Weak Up", because the fan's tacho output usually has an open collector output.
Pump	The GPIOx signal is set to logic 1 to enable a pump. Use the "CHx Pump Control" settings to configure the behavior.
Dev Adr +1 Dev Adr +2 Dev Adr +4	The GPIOx signal is used as input signal. For each pin which is logic 1 and with this function enabled, 1, 2 or 4 is added to the device address. This is only done once at startup.

Function Name	Description
Pulse Input	When this pin is logic 0 the target current used by the current control loop is set to the Value of "Min Nominal Current". When the pin is logic 1, the target current is left unaltered (= Nominal Current). When multiple pins are configured as Pulse Input the GPIO with the highest number is used. If no GPIO is configured as Pulse Input the target current is left unaltered.

The Logic Level of each pin can be assigned under "Level Assignment" in the "GPIO" tab. For inputs, Logic Level "Positive" means that a high voltage is read in as logic 1 while a low voltage (pin connected to GND) is logic 0. This can be inverted by setting the parameter to "Negative". For outputs, the logic level inverts the Signal when set to "Negative". This means that the "LDD OK" signal outputs 0 V when the LDD is in "Ready" or "Run" status and the Level Assignment is set to "Negative".

The Pins can be individually configured under "Hardware Configuration" in the "Advanced" → "GPIO" tab. When a signal is used as an input the hardware configuration must be made accordingly or the function will not be operational. The hardware configuration is described in **Error! Reference source not found..**

Table 5. GPIO Pins Hardware Configuration.

Function Name	Description
In WeakNo	The GPIO Pin is configured as Input. No PullUp or PullDown Resistor is activated.
In WeakUp	The GPIO Pin is configured as Input. A weak PullUp Resistor to 3.3 V of approximately 50 kΩ is activated.
In WeakDown	The GPIO Pin is configured as Input. A weak PullDown Resistor of approximately 50 kΩ is activated.
OUT PushPull	The GPIO Pin is configured as Push Pull Output. No PullUp or PullDown Resistor is activated.
OUT OD NoPull	The GPIO Pin is configured as an Open Drain Output. No PullUp or PullDown Resistor is activated.
OUT OD WeakUp	The GPIO Pin is configured as an Open Drain Output. A weak PullUp Resistor to 3.3 V of approximately 50 kΩ is activated.

For input signals like buttons, it is usually easier to set the pin to "Negative" logic and "In Weak Up". This way the switch can be connected between the GPIO pin and GND.

6.2 Cooling fans

Up to two fans can be connected and controlled by the device. The "Fan Control Feature" is intended to keep the temperature below a specified temperature, by using the slowest fan speed possible. For example, this can be used to cool the LDD itself, or the heatsink of your laser system. Please refer to chapter 6.1 on how to configure the fan control signals.

6.2.1 Fan Requirements

The "Fan Control Feature" is only compatible to fans with the following features:

- PWM control signal input to control the fan speed. The device generates a 25 kHz or 1 kHz PWM signal from 0 to 100%. 3.3 V voltage level.
- Optional, but recommended: frequency generator signal output which represents the rotation speed. The output should be an open collector output signal.

For the logic level voltage definitions of the LDD, please refer to the datasheet.

6.2.2 Fan Recommendations

To obviate the need for a separate power supply, it is recommended to use a fan with the same supply voltage as the LDD needs.

We have tested the following fans, which fulfill the above-mentioned requirements. All fans stop (0 rpm) at 0% PWM signal.

Table 6. Recommended fans.

Fan	Manufacturer P/N	DigiKey P/N	Voltage [V]	Power [W]	Dimensions [mm]		
					L	H	W
1	FFB0424VHN-TZT4	603-1818-ND	24	2	40	40	28
2	AFB0624EH-SP50	603-1803-ND	24	6	60	60	25
3	PFB0824DHE-YDG	603-2028-ND	24	32	80	80	38
4	AFB1224EHE-EP	603-1735-ND	24	20	120	120	38
5	FFB0412VHN-TP03	603-1206-ND	12	2	40	40	28
6	AFB0612DH-TP11	603-1211-ND	12	10	60	60	25
7	EFC0812DB-F00	603-1159-ND	12	4	80	80	15
8	FFC1212D-F00	603-1789-ND	12	17	120	120	25
9	PF40281BX-000U-S99	259-1666-ND	12	11	40	40	28

6.2.3 Optimized Settings

The following values are optimal settings for the CHx Fan Speed Controller parameters in combination with the corresponding fan. The bypass option ("Bypassing Speed Controller") is used for fans with integrated speed controller, to disable the speed controller.

Table 7. Suggested fan settings.

Fan	0% Speed [rpm]	100% Speed [rpm]	Kp [%/rpm]	Ti [s]	Td [s]	Bypass
1	-	-	-	-	-	Yes
2	-	-	-	-	-	Yes
3	-	-	-	-	-	Yes
4	-	-	-	-	-	Yes
5	0	10000	0.005	0.5	0	No
6	0	10000	0.005	0.5	0	No
7	0	4200	0.005	0.5	0	No
8	0	4400	0.005	0.5	0	No
9	0	22500	-	-	-	Yes

6.2.4 Connecting the Fan to the Device

- If the fan supports the same supply voltage as the TEC Controller, it is recommended to connect the fan's GND and VCC to the LDD's GND and VIN, respectively.
- If a separate power supply is used for the fan, make sure that the two GND terminals of the power supplies are connected. Never leave the fan's GND unconnected when the fan is powered. Otherwise, the GPIOx pins may be destroyed.
- Assign the correct function to the GPIO signals (see chapter [6.1 GPIO Control Signals](#)).
- The PWM input of the fan must be connected to GPIO5 or GPIO6, since only these outputs generate a PWM signal. As an example, you can configure the GPIO as follows:
 - Pin: GPIO4
 - Function: Fan PWM
 - Level Assignment: Positive
 - Hardware Configuration: OUT PushPull
- The frequency output signal of the fan can be connected to any of the GPIO signals. As an example, you can configure the GPIO as follows:
 - Pin: GPIO3
 - Function Fan Tacho
 - Level Assignment: Positive
 - Hardware Configuration: IN WeakUp

6.2.5 Control Function

The Fan control feature uses two PID controllers.

The first PID controller sets the required cooling power depending on the temperature of the heatsink. In most cases only P control is used. We recommend a value of 30 %/°C for Kp. Thus, for a target temperature of 40 °C the fan will rotate with 0% speed at 40 °C and 90% speed at 43 °C.

This required cooling power is then converted into a nominal fan speed. For example, if the minimum and maximum fan speeds are set to 1000 rpm and 11000 rpm, respectively, the required cooling power of 50% is converted into a nominal fan speed of 6000 rpm.

The second PID controller sets the fan speed by varying the PWM output signal until the nominal fan speed is reached.

The "Fan Speed Controller" should be set up before without temperature regulation of the heatsink. This can be done by setting both the "Target Temperature" and the "100% Speed" to a high value. This allows to use the "0% Speed" as a fixed rotation speed. The fan should reach the nominal speed as fast as possible.

It is possible to stop the fan by an external GPIOx signal. This is useful, e.g., if a door of a compartment is opened (see chapter [6.1 GPIO Control Signals](#)).

If a hysteresis is needed the parameters "Min Speed Start" and "Min Speed Stop" can be used. If those values are set to zero, they will be ignored.

6.2.6 Fan Parameter Description

Table 8. CHx Fan Control Enable

Parameter Name	Options and Description
Fan Control Enable	<ul style="list-style-type: none"> Disabled Enabled: Enables the fan controller

Table 9. CHx Fan Temperature Controller

Parameter Name	Options and Description
Actual Temperature Source	<ul style="list-style-type: none"> External 1: the actual temperature for the temperature controller is taken from the external temperature input 1. External 2: the actual temperature for the temperature controller is taken from the external temperature input 2. Device LD: the actual temperature for the temperature controller is taken from the temperature of the LDD's output stage. Device TEC: this temperature source is not available at time of publication.
Target Temperature	Target temperature (set point) for the temperature controller
Kp, Ti, Td	PID controller parameters for the temperature controller

Table 10. CHx Fan Temperature Controller

Parameter Name	Options and Description
0% Speed	Minimum rotation speed
100% Speed	Maximum rotation speed
Min Speed Start	Minimal speed above which the fan is started
Min Speed Stop	Minimal speed below which the fan is stopped
Kp, Ti, Td	PID controller parameters for the Fan Speed Controller
Bypassing Speed Controller	<ul style="list-style-type: none"> Yes: Disables the Fan Speed Controller. "Relative Cooling Power" is written directly to the PWM output. No: The built-in speed controller is used.
Fan Surveillance	Disables Error 175 (ERROR_FAN_CONTROL_LIMIT) and Error 176 (ERROR_FAN_BLOCKED) This can be used when no tachometer signal is available.

7 Special Functions

7.1 Parameter Handling

7.1.1 Settings Dump (.mepar File) with the Service Software

In cases where many or all settings of a device are to be changed from a host software or a host microcontroller, a settings dump function is available. This generates a file which can be dumped to a device using third party host systems.

- Every parameter which is labeled with “New”, that contains information will be stored in the .mepar file.
- In the “Maintenance” tab click “Create File” in the box “Create *.mepar file (for Settings Dump)”.

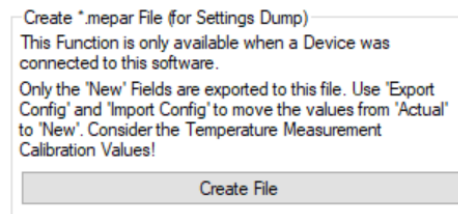

Figure 18. Settings Dump.

- For every parameter stored in the .mepar file, a line contains the parameter string that is specific to function, firmware and device type.
- Using the MeCom communication protocol, the .mepar file can be sent line-by-line to one or several devices. These batch configurations will immediately become active.
- It is also possible to download just one single setting (i.e., one line of the .mepar file) directly from the Service Software to a device.
- Copy a line from the file and paste it in the field. Click “Send String”.

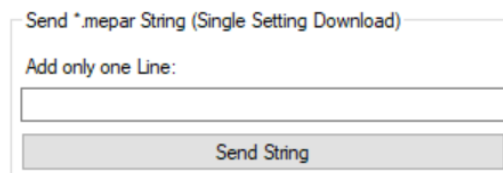

Figure 19. Single Setting Download.

7.1.2 Parameter System Save to Flash Configuration (Save Data to Flash)

See tab “Advanced” > “System”.

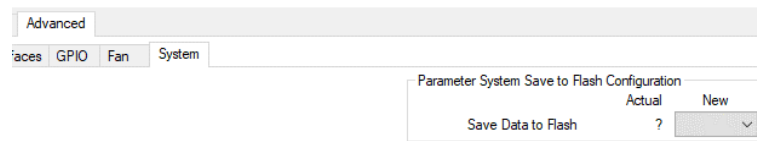

Figure 20. Flash Configuration.

Table 11. Settings saving behavior.

Option	Description
Enabled	Default setting. Every time a parameter is changed a 0.5 s delay timer is started. After expiration, all changed data is saved to the non-volatile flash.
Disabled	Saving data to the non-volatile flash is disabled. This is useful when the device is connected in a bus system, where parameters are changed regularly. This prevents early failure of the flash memory due to frequent rewrites.

8 Troubleshooting and Errors

8.1 Quick Reference

Table 12. Typical issues.

Problem	Possible Reason	Possible Solution
The Service Software is not starting.	The Service Software does not work with 64-bit versions of Microsoft Visual C++ 2015 Redistributable Package	Make sure that the correct version (32-bit) of Microsoft Visual C++ 2015 Redistributable Package is installed.
The output is suddenly switched off.	An error happened.	Check the error message in the "Monitor" tab.
The firmware is too old.	The firmware is too old to connect to the Service Software.	Update the firmware.
PID upper error while the output current is rising.	The anode voltage is insufficient to support driving such a current.	Check if the laser characteristics are correct.
FET SOA error.	The SOA is being crossed.	See 3.1 Theory of Operation and the device datasheet.
VLDA over/under.	The VLDA voltage does not reach the setpoint.	Check if the input voltage is sufficiently higher than the setpoint. Disconnect the load and check if VLDA works normally. Check load for short circuits.

8.2 Error Numbers, Instances and Parameters

- Error Numbers from 1 through 99, excluding 30 through 39, designate error conditions that are universal across the whole range of Meerstetter devices
Error numbers starting from 100 designate conditions that are specific to LDD-1321 devices (see tables below).
- Error Instance can designate the involved instance of a functionality or be useful information for Meerstetter Engineering technical support.
- Error Parameters are additional information to help Meerstetter Engineering technical support in the process of error diagnosis or remote debugging.

8.2.1 Error Numbers 1 – 99 (universal)

Table 13. Processor Errors

#	Description	Error Condition
1 – 10	MCU system malfunction	-

Table 14. HMI Errors

#	Description	Error Condition
11	Emergency stop was triggered by LTR-1200	-
12	LTR-1200 HMI regularly sends 'free' signals to all rack-internal devices such that they can activate their output stages (if enabled)	No signal received for more than one second

Table 15. Parameter System Errors

#	Description	Error Condition
20-21	Internal parameter system malfunction	-
22	Parameter set corrupt	Configuration flash empty or defect (fix: see error #23)
23	Parameter set incompatible with current firmware version	Load .ini file saved prior to FW update, or Default.ini
24	Firmware does not recognize valid device	-
25	Internal parameter system malfunction	Access to a non-existing instance
26	Internal limit system malfunction	-
27	Parameter write or read wrong datatype function used	-
28	Parameter write value out of range	-
29	Parameter save to flash called from interrupt	-

Table 16. Power Supply Errors

#	Description	Error Condition
30	Input voltage net too low	< 10.5 V
31	Input voltage net too high	> 25.5 V
32	Internal 8 V power net too low	< 7.5 V
33	Internal 8 V power net too high	> 8.225 V
34	Internal 5 V power net too low	< 4.7 V
35	Internal 5 V power net too high	> 5.25 V
36	Internal 3.3 V power net too low	< 3.1 V
37	Internal 3.3 V power net too high	> 3.5 V
38	Internal -3.3 V power net too low	< -3.5 V
39	Internal -3.3 V power net too high	> -3.1 V

Table 17. Flash Memory Errors

#	Description	Error Condition
50	On-board flash failure	Write Timeout
51	On-board flash failure	Erase Timeout
52	On-board flash failure	Invalid Address

Table 18. Communication Error

#	Description	Error Condition
53	Send buffer overflow error	-

Table 19. Device Temperature and Hardware Errors

#	Description	Error Condition
60	Device running too hot	See datasheet.
61	Communication error with I/O hardware during factory test	-

8.2.2 Error Numbers 100 – ... (specific to LDD-1321 devices)

Table 20. Power Output Errors

#	Description	Error Condition
100	Output overcurrent	> "Current Error Threshold"
101	Output overvoltage	> "Voltage Error Threshold"
102	FET SOA error	The safe operating area of the FET was violated
103	PID upper limit error	Current control saturated at its upper limit
104	Fast switchoff output overcurrent error	Device overcurrent
105	VLDA over	$0.2 \text{ V} + 10 \% \cdot V_{VLDA_{nom}}$
106	VLDA under	
107	LDD VLDA is off! Enable it before turning on the current.	Output was enabled with VLDA off
108	LDD output current deviation too high.	A high deviation of the current from the setpoint has been detected. Possible reasons include shorts between your load and any fixed potential. Both laser terminals need to be floating.
110	Interlock error	Interlock low

Table 21. External Temperature Measurement Errors

#	Description	Error Condition
140	12 bit ADC raw value below safety margin	< 40 (1%)
141	12 bit ADC raw value above safety margin	> 4050 (99%)
142	Measured temperature too low	< "Lower Error Threshold"
143	Measured temperature too high	> "Upper Error Threshold"

Table 22. Fan Control Errors

#	Description	Error Condition	Further Information
175	The fan does not reach the desired rotation speed.	Fan PWM Signal is 100% and the reached Speed is < 60% of the nominal speed for 12 s.	Check if your fan can reach the defined "100% Speed [rpm]" in the "Advanced > Fan" tab. If not, reduce the "100% Speed [rpm]" to a value, which your fan can reach. Check whether the fan is broken.
176	The fan does not rotate.	Fan Speed = 0 and PWM Level > 35% for 10 s.	Check if the fan wiring and GPIO configuration of the TEC Controller are correct. Check whether the fan is blocked or broken.

Table 23. Various Errors

#	Description	Error Condition
183	No package has been received within the specified watchdog timeout time	-

A Change History

Date of change	Version	Changed/ Approved	Change / Reason
2023-06-14	A	RS / HS	• Initial Release