

Setup Guide – SKT-1165



**meerstetter
engineering** 

 Member of Berndorf Group



Index

1	General Information	4
1.1	Overview	4
1.2	Block Diagram	5
1.3	Additional requirements	5
1.4	SKT-1165 vs. TEA-1145.....	6
2	Setup	7
3	Safety Notes	9
3.1	Intended use.....	9
3.2	Hot Surface and Air	9
3.3	Condensation Water.....	9
3.4	Power Supply	9
3.5	Electrostatic Discharge	10
3.6	EU Declaration of Conformity	10
3.7	General Safety Warnings.....	10
4	Further Information	11
A	Change history	12

Meerstetter Engineering GmbH

Schulhausgasse 12

CH-3113 Rubigen

Switzerland

Phone: +41 31 529 21 00

Email: contact@meerstetter.ch

Meerstetter Engineering GmbH (ME) reserves the right to make changes without further notice to the product described herein. Information furnished by ME is believed to be accurate and reliable. However typical parameters can vary depending on the application and actual performance may vary over time. All operating parameters must be validated by the customer under actual application conditions.

Document 5248F

Release date: 4 June 2026

1 General Information

1.1 Overview

The starter kit consists of the following components:

Components	Description
TEC Controller TEC-1091	Controller which drives / controls the Peltier element, the fan, and the display.
Display DPY-1113	Status display.
Peltier Assembly TEA-1145 <ol style="list-style-type: none">1. Peltier Element2. NTC Thermistor3. NTC Thermistor4. Heat Sink5. FAN6. Power Connector7. USB Connector	<ul style="list-style-type: none">> Cooling and heating (internally mounted)> Measurement of object temperature (internally mounted)> Measurement of sink temperature (internally mounted)> Removal of heat> Used for increased heat removal and improves the thermal efficiency of the Peltier assembly



Figure 1: Overview SKT-1165

1.2 Block Diagram

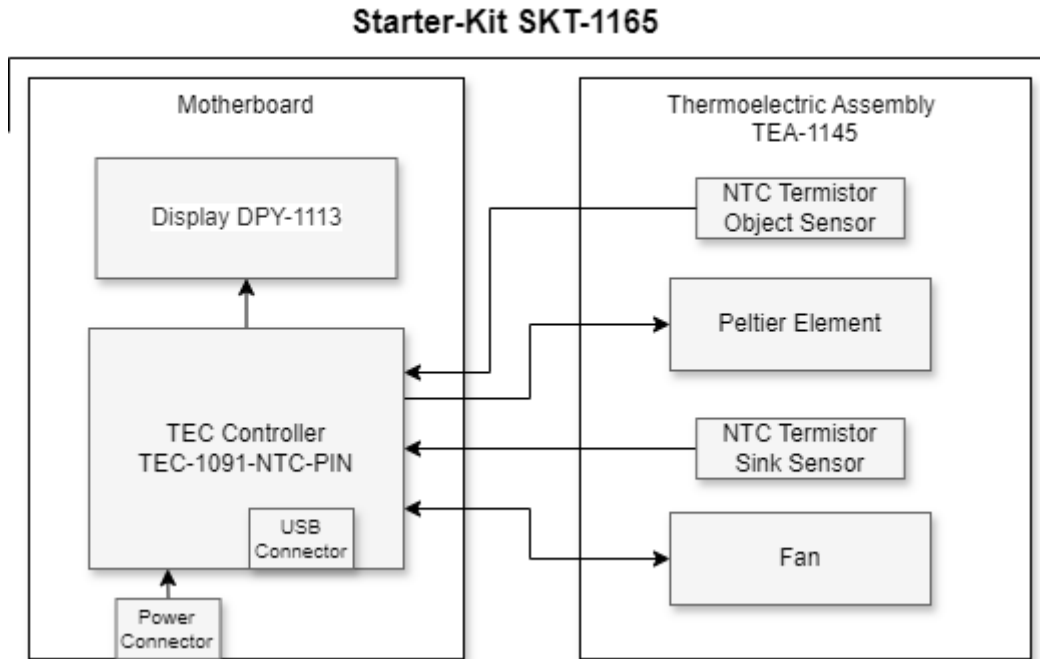

Figure 2: Block Diagram SKT-1165

1.3 Additional requirements

These parts are not included as standard:

- PC with Microsoft Windows 7 or newer
- Power supply (24 V, 5 A or more); Recommended [power supply](#) (cable length < 3m)

1.4 SKT-1165 vs. TEA-1145

The TEA-1145 (Thermoelectric Cooling Assembly) and the SKT-1165 (Starter Kit) have the same TEC design. The SKT already has a TEC controller, a display and a motherboard that has the connections for the TEA.

The TEA is the Thermoelectric Cooling Assembly and can be seen in Figure 3 at position 1, it is basically the top half of the Starter Kit.



The TEA can also be removed from the SKT by simply removing the four side screws, position 2 in Figure 3.

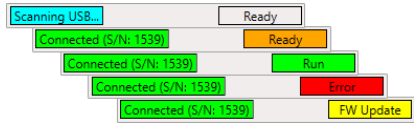

Figure 3: SKT vs. TEA

2 Setup

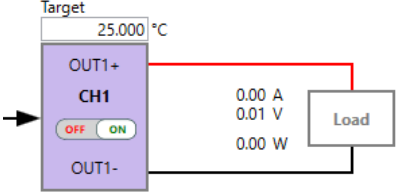
Step	Action	Information / Feedback														
1	Hardware Setup															
1.1	✘ Unpack your Starter Kit	① Your Starter Kit will be delivered fully assembled.														
1.2	✘ Be sure that the power supply has the following polarity:  ✘ Plug in the power supply.	① The power supply must be able to provide enough electric power (24 V, 5 A). A fitting power supply can be ordered from our web shop. We can recommend the following power supply .														
1.3	✘ Connect the DC-Jack from the power supply to the X0 connector (number 6 in Figure 1) on the motherboard of the TEC Controller of your Starter Kit.	🔍 The green LED starts flashing continuously on the TEC Controller. 🔍 The TEC Controller starts to cool / heat to 15°C.														
2	Install and Start the Software															
2.1	✘ The latest TEC-Family Configuration Software Package (.msi) can be downloaded here. ✘ The compatible software can be found on the TEC label (see below). Any other versions can be downloaded here. TEC-1091-NTC-PIN S/N xxxxx_V1.04 <div style="border: 1px solid red; padding: 2px; display: inline-block;">FW v6.31</div> meerstetter.ch ✘ Execute the MSI-file and follow the instructions.	① The MSI setup procedure will also provide you with the FTDI USB driver and Microsoft .NET files if you do not have the necessary versions already installed. 🔍 The "... Additional" folder also contains the firmware upgrade file for the TEC Controller itself and some other helpful stuff.														
2.2	✘ Connect the TEC Controller on X3 to your PC using the provided Mini-USB-B cable (number 7 in Figure 1 Overview SKT-1165). ✘ Open the Configuration Software.	🔍 When the TEC Configuration Software is connected to a TEC Controller, the status of the device is displayed in the bottom of the software window:  🔍 If an error occurs, the "Device Status" changes to red. <div style="background-color: red; color: white; padding: 5px; display: inline-block; font-weight: bold;">Error</div> By hovering over the field, you can get more information about the error. <div style="border: 1px solid gray; padding: 5px; font-size: small;"> <p>TEC Configuration Software / System Status</p> <p>System is in error condition. Please check the errorText.</p> <p>Error Number: 142</p> <p>Error Text:</p> <p>Instance: 1</p> <p>Parameter: 9</p> <p>LR Temperature Measurement Error</p> <p>Measured LR temperature < 'Lower Error Threshold' [User set]</p> <p>Click on this icon to Reset</p> <p>Communication Interface Information:</p> <table border="0"> <tr><td>Instance</td><td>1</td></tr> <tr><td>MeParID_Status</td><td>104</td></tr> <tr><td>MeParID_ErrorNr</td><td>105</td></tr> <tr><td>MeParID_ErrorInst</td><td>106</td></tr> <tr><td>MeParID_ErrorParameter</td><td>107</td></tr> <tr><td>MeParID_ErrorText</td><td>110</td></tr> <tr><td>MeParID_Reset</td><td>111</td></tr> </table> <p>Please check the documentation for more details about those parameters.</p> </div>	Instance	1	MeParID_Status	104	MeParID_ErrorNr	105	MeParID_ErrorInst	106	MeParID_ErrorParameter	107	MeParID_ErrorText	110	MeParID_Reset	111
Instance	1															
MeParID_Status	104															
MeParID_ErrorNr	105															
MeParID_ErrorInst	106															
MeParID_ErrorParameter	107															
MeParID_ErrorText	110															
MeParID_Reset	111															

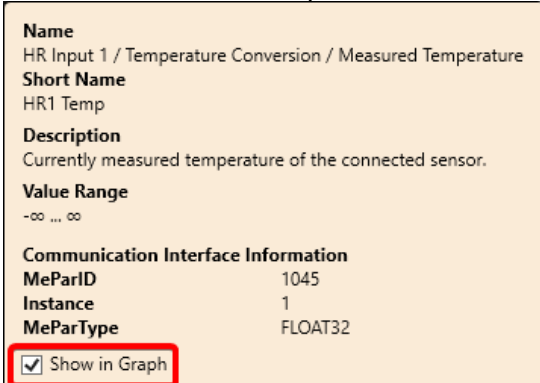
3	Temperature Control	
3.1	<p>✘ In the main window click in to the “Target” field and set it to 20.</p> 	<p>① Our goal is now to keep an object at a constant temperature. First, we set the target temperature.</p>
3.2	<p>✘ Save the changed settings to the TEC Controller by hitting [Enter] or clicking on “Unsaved parameters” in the bottom right corner of the window.</p> <p>Unsaved parameters</p>	<p>① Generally, you must set values by typing them into the corresponding fields and by hitting [Enter].</p>
3.3	<p>✘ Observe the temperatures in the “Graph” window. In the main window click on the following icon.</p> 	<p>① This procedure can be done with every parameter in the software.</p> <p>🔍 The temperature will converge to 15 °C.</p>
3.4	<p>✘ Add a curve to the graph by hovering over the parameter field and check the checkbox “Show in Graph”.</p> 	

3 Safety Notes

3.1 Intended use

The Starter Kit SKT-1165 is a complete thermal solution to control the temperature of the top plate between -10 °C and $+60\text{ °C}$. It is made for the use in inside laboratories or offices at normal room temperature and humidity. Use the SKT-1165 in accordance with these instructions.

See chapter Overview in this document for the description of the components.

Check out our website for the main features: [SKT-1165](#)

3.2 Hot Surface and Air

The hot/cold plate is intended temperature range is -10 °C to $+60\text{ °C}$. The hot surface warning sign is not applied to the Hot/Cold plate because it is the main function of the SKT-1165, and the surface temperature is limited to 60 °C .



Figure 4: Hot/cold Plate of the SKT-1165

The red marked area in the picture is the hot/cold plate.

The fan is mounted inside the device, see also chapter [Overview](#). If the fan is running, the air is drawn in at the bottom and blown out at the top (red and blue arrows). Keep a distance to other devices and do not block the air.

3.3 Condensation Water

The Hot/Cold plate is intended to get cold, and the plate might get icy with temperatures below 0 °C depending on the air humidity and the duration of the low temperature.

When warming up, the plate might get wet by condensation or melting ice. The water does not do anything to the aluminium plate or the insulating foam. The user must contain or dry off the water to make sure that no water gets into the open electronics of the display and the controller.



Figure 5: Water on the hot/cold plate

3.4 Power Supply

A nominal power supply of $24\text{ VDC} / 5\text{ A}$ is recommended for the SKT-1165. The supply voltage range is $22 \dots 25\text{ VDC}$.

Make sure the polarity of the power supply is correct, reversing the polarity of the supply causes the fuse to blow. The correct polarity of the Barrel Jack Plug is to have the 24 VDC on the inner Pin and 0 VDC on the outer shell.

There is no other protection against reverse polarity. Replacing the fuse must be done by Meerstetter Engineering GmbH or by trained personnel after contacting the support, but this will void any warranty.

The current recommendation of 5A includes a power reserve. This enables the SKT-1165 to deliver the full power of 40W cooling power. A smaller current rating is possible if the user limits the output current of the controller accordingly.

The length of the cable between the power supply and the SKT-1165 must be shorter than 3 meters.

3.5 Electrostatic Discharge

The SKT-1165 can withstand electrostatic discharges (ESD) of 8kV human body model. Due to the open design, it is advised to touch the controller and the display only in a ESD protected environment.

3.6 EU Declaration of Conformity

The SKT-1165 is CE marked and meets the requirements regarding EMC and RoHS. The EU Declaration of Conformity can be provided on request.

3.7 General Safety Warnings

- ✓ Be attentive, pay attention to what you are doing and use common sense when working with the appliance.
- ✓ Place the device on a stable, dry and level surface.
- ✓ No water or other liquid should get in contact with the display, the controller or the fan.
- ✓ The surface of the plate can become hot and cause burns, let it cool down and before transport.
- ✓ The device should not be operated near flammable materials or on heat-sensitive surfaces. Ensure sufficient distance from other devices.
- ✓ Do not open the device or disconnect internal cables.

4 Further Information

Component	Link	Reference
TEC Controller	TEC-1091 Datasheet	
	PID Autotuning TEC Family User Manual	Page 21
Display	DPY-1113 Display Datasheet	
	Display Software Configuration TEC Family User Manual	Page 34
Peltier Element	TE72001-241-060BS	
Object Temperature Sensor	NTCLE305E4103SB	
Sink Temperature Sensor	NTCALUG01A103F161	
Fan	9GA0824P4J001	
Recommended Power Supply	GST120A24-P1M	

A Change history

Date of change	Doc/Version	Changed/ Approved	Change / Reason
15 February 2021	A	LS	<ul style="list-style-type: none"> Initial release
19 March 2021	B	XF	<ul style="list-style-type: none"> Removed general service software parameter information from annex as it is the same information as can be found in the TEC-Family User Manual Adjusted the document to the new document template: <ul style="list-style-type: none"> Added index Added Meerstetter disclaimer Fixed various typos and formatting errors
07 July 2021	C	XF	<ul style="list-style-type: none"> Added step 3.3 in the Setup > Temperature Control section that explains how to save settings to the TEC Controller.
16 February 2023	D	NZ/RK	<p>General revision and adaptation to Starter Kit v2.00</p> <ul style="list-style-type: none"> Changed all images of the SKT-1165. Deleted step 1.4 and 1.5, they are obsolete. Modified step 1.3, because the new Starter Kit has only one plug for the power supply. Adjusted the temperature in step 1.3 corresponding to the default config.ini. Adjusted the temperature in step 3.1 and 3.3 so that the temperature is different to that one in step 1.3. Updated the Links for the new Peltier element, object and sink temperature, the fan and the power supply. Updated index Added Package Outline and Pin Configuration
14 September 2023	E	NZ	<ul style="list-style-type: none"> Added the chapter 1.2 "SKT-1165 vs. TEA-1145" and 3 "Settings"
20 April 2026	F	NZ / MBU	<ul style="list-style-type: none"> Chapter 1 Safety Notes added, following chapters numbered accordingly. Max. cable length added in chapter 2.4 Removed chapter 3 "Settings" Updated to be compatible with FW v6.30 and HW v2.30.