

Advanced OEM CW Laser Diode Driver



Description:

The LDD-1303 is a current source designed to precision-drive laser diodes in continuous wave applications. Its power converter topology allows for an output voltage smaller, equal, or larger than the input voltage. This enables the LDD to drive laser diodes with up to 120 V compliance voltage from a single 48 V power supply.

The LDD-1303 offers various safety features, including two inputs for laser diode temperature monitoring.

The device can be fully digitally controlled, the firmware is upgradeable and various digital communications interfaces are available.

A 0 - 10 V analog Input as well as a 0 - 10 V analog output are integrated. Additionally, Laser Power Control using a photodiode is possible using the on-board photodiode amplifier (optional).

Laser Diode Driver:

- Output Current: 0 - 20 A, < 0.4% Ripple
- Compliance Voltage: 1 - 120 V

Input Characteristics:

- DC Input Voltage: 10.5 to 48 V

Main Features:

- Internal Generators: Nominal Current
- Error: Ultra-Fast Switch-off for optimal LD protection
- Configuration / Diagnosis: via USB / RS485 / RS232 TTL
- Dimensions (L x W x H): 190 mm x 70 mm x 28 mm
- Efficiency: > 95 % (@ > 50 % Load)
- Cooling: Over Base Plate

Communication Interfaces:

- USB 2.0
- RS485
- RS232 TTL

Other Features:

- 2 Temperature Sensor Inputs for NTC Thermistors
- Light Measurement Input for Photodiode (LPC Option)
- 0-10 V Analog Input
- 0-10 V Analog Output
- Interlock Input

Digital I/O Configurable Features:

- Enable
- LDD Run Output
- And more configurable functions

Absolute Maximum Ratings¹

Supply voltage (DC)	53 V
Supply current (DC)	53 A
Output current	25 A
Output voltage	130 V

Operating Ratings

System base plate	< 50 °C
Operation temperature	0 – 50 °C
Storage	-40 – 80 °C
Humidity	5 – 95 %, non-condensing

Operating Characteristics

Unless otherwise noted: $T_A = 25\text{ °C}$, $V_{IN} = 48\text{ V}$

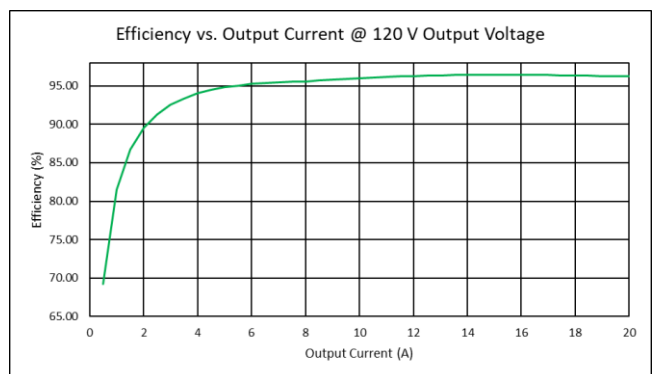
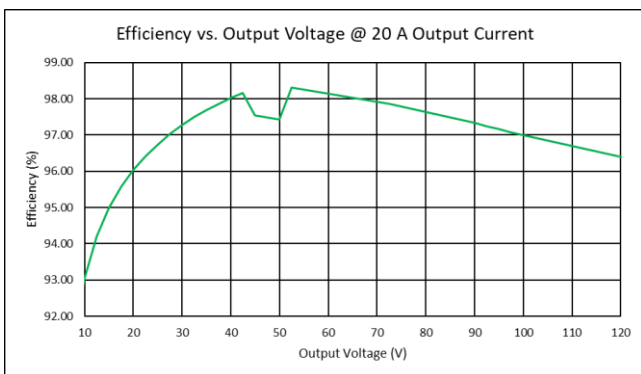
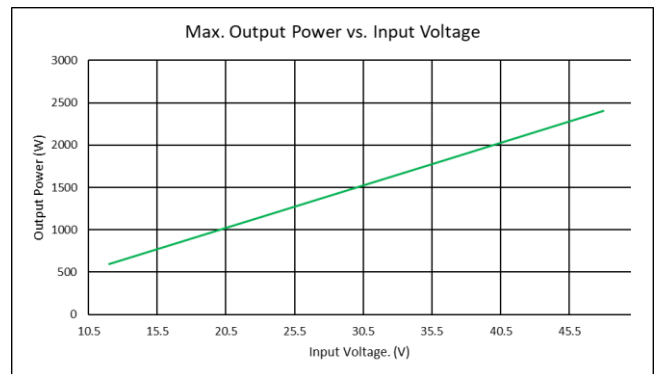
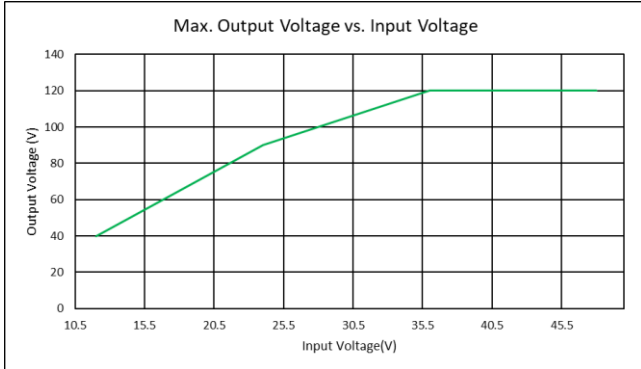

¹ Exceeding the Absolute Maximum Ratings may permanently damage the device

Electrical Characteristics

Unless otherwise noted: $T_A = 25\text{ °C}$, $V_{IN} = 48\text{ V}$, $V_{LD} = 120\text{ V}$

Symbol	Parameter	Conditions	Min	Typ	Max	Units
DC Power Supply Input:						
V_{IN}	Supply voltage		10.5	48	53	V
V_{IN_RIPPLE}	Ripple tolerance ²			300		mV _{PP}

Output Characteristics

Unless otherwise noted: $T_A = 25\text{ °C}$, $V_{IN} = 48\text{ V}$, $V_{LD} = 120\text{ V}$

Symbol	Parameter	Conditions	Min	Typ	Max	Units
Output CW:						
I_{OUT}	Current range		0		20	A
$T_{\text{coefficient}}$	Temp. coefficient	$I_{out} = 20\text{ A}$, $T_A = 10\text{ °C}$ to 50 °C		3464		ppm/K
I_{OUT_RES}	Current resolution			2		mA
I_{OUT_RIPPLE}	Current ripple	$I_{out} > 2\text{ A}$		0.4 ³		%
I_{OUT_ACC}	Current Accuracy	Calibrated		30	40	mA
V_F	Diode compliance voltage	$V_{IN} = 48\text{ V}$	1 ⁴		120	V
V_{OUT_MAX}	Output voltage maximum			120		V
V_{OUT_ACC}	Voltage accuracy	Calibrated, $I_{out} < 1\text{ A}$		100		mV
P_{OUT}	Output power	$V_{LD} = 120\text{ V}$			2.4	kW
I_{OUT_Rise}	Output current rise time	10% to 90%, PID Optimized, $L_{Load} < 500\text{ nH}$, $I_{OUT} = 20\text{ A}$			350	μs

Safety Characteristics

Unless otherwise noted: $T_A = 25\text{ °C}$, $V_{IN} = 48\text{ V}$, $V_{LD} = 120\text{ V}$

Symbol	Parameter	Comments	Min	Typ	Max	Units
I/O Ports:						
$t_{OFF_CURRENT}$	Overcurrent				TBD	μs
t_{OFF_OPVAL}	Operating Values	Voltages, currents			TBD	μs
t_{OFF_SFAIL}	System failure	System status			TBD	μs

External Temperature Measurement (NTC only)

$T_A = 25\text{ °C}$, measurement configuration = 12 bit / 2-wire / unshielded cable < 50 mm, °T probe = NTC B_{25/100} 3988K R₂₅ 10k

Symbol	Parameter	Test Conditions / Hints	Min	Typ	Max	Units
$R_{LR, RANGE}$	Range	Corresponding temperature range	295	130 to -21	106400	Ω °C

² Input ripple voltage can directly influence the ripple current at the output

³ Measured at $I_{OUT} = 20\text{ A}$ and $V_{LD} = 100\text{ V}$

⁴ Current Ripple may increase, and current control performance may decrease at compliance voltages below 5V depending on load

General Purpose Digital I/O Characteristics (GPIO1 ... GPIO10)

Unless otherwise noted: $T_A = 25\text{ °C}$

Symbol	Parameter	Test Conditions	Min	Typ	Max	Units
Input Characteristics:						
U_{IH}	Logic high input threshold		2			V
U_{IL}	Logic low input threshold				1	V
U_{IMAX}	Maximum input voltage		-0.3		5.5	V
Output Characteristics:						
U_{OH}	Logic high output voltage	Output current 8mA	2.8		3.3	V
U_{OL}	Logic low output voltage	Input current 8mA			0.4	V
Z_{OUT}	Output Impedance		110	120	150	Ω
I_{OUT}	Output Sink or Source Current			± 8	± 20	mA
ESD Protection:						
UPP	ESD discharge	IEC61000-4-2		18		kV

Analog Input and Output Characteristics

Unless otherwise noted: $T_A = 25\text{ °C}$. Voltages referenced to X2 (GND)

Symbol	Parameter	Test Conditions	Min	Typ	Max	Units
Input Characteristics:						
U_{I+}	Voltage at the Analog In + Pin		-1		11	V
U_{I-}	Voltage at the Analog In - Pin		-1		11	V
U_{IN}	Nominal Input Voltage (difference between In + and In -)		0		10	V
Output Characteristics:						
U_o	Analog Output Voltage		0		10	V
I_{OUT}	Analog Output Current				20	mA

Interlock Input Characteristics

Unless otherwise noted: $T_A = 25\text{ °C}$.

Symbol	Parameter	Test Conditions	Min	Typ	Max	Units
Input Characteristics:						
V_{IAct}	Interlock active input voltage range	Voltage range which is detected as active input	3		30	V
V_{IORM}	Maximum Working Insulation Voltage				120	V

Photodiode Input Characteristics (only available with LPC Option)

Unless otherwise noted: $T_A = 25\text{ °C}$.

Symbol	Parameter	Test Conditions	Min	Typ	Max	Units
Input Characteristics:						
I_{in}	Photodiode current	-LPC-4mA	0		4	mA
		-LPC-2mA	0		2	
		-LPC-1mA	0		1	
		-LPC-0.5mA	0		0.5	

Device Connectors Overview

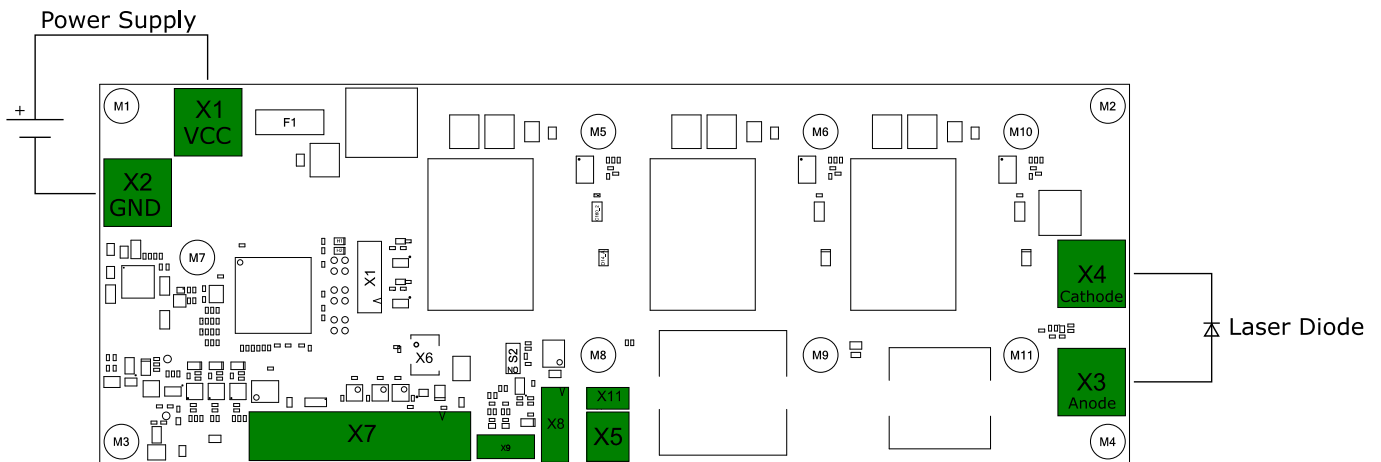

USB Connector X5 and X11

The LDD-1303 can be equipped with a vertical and/or a horizontal USB-Connector (See “LDD-1303 Ordering Information”). If both USB-Connectors are soldered in only use one connector at a time. Otherwise, serious damage to the USB Host may occur.

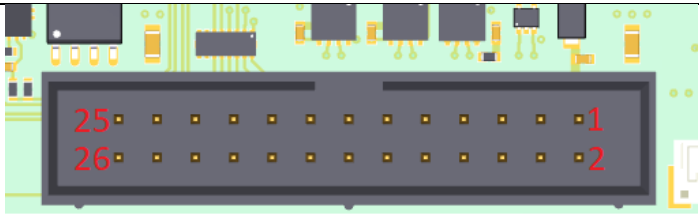
Interface Connector X7		Mating Connector: Würth 61202623021	
			
Pin		Pin	
1	+5V	14	GPIO4
2	GND	15	GPIO5
3	+3.3V	16	GPIO6
4	RS485 1 A/D+	17	GPIO7
5	RS485 1 B/D-	18	GPIO8
6	RS232 TTL RX	19	GPIO9
7	RS232 TTL TX	20	GPIO10
8	GND	21	Not Connected/Reserved
9	Do Not Connect	22	Not Connected/Reserved
10	Do Not Connect	23	Analog GND
11	GPIO1	24	0-10V Analog Out
12	GPIO2	25	0-10V Analog In +
13	GPIO3	26	0-10V Analog In -

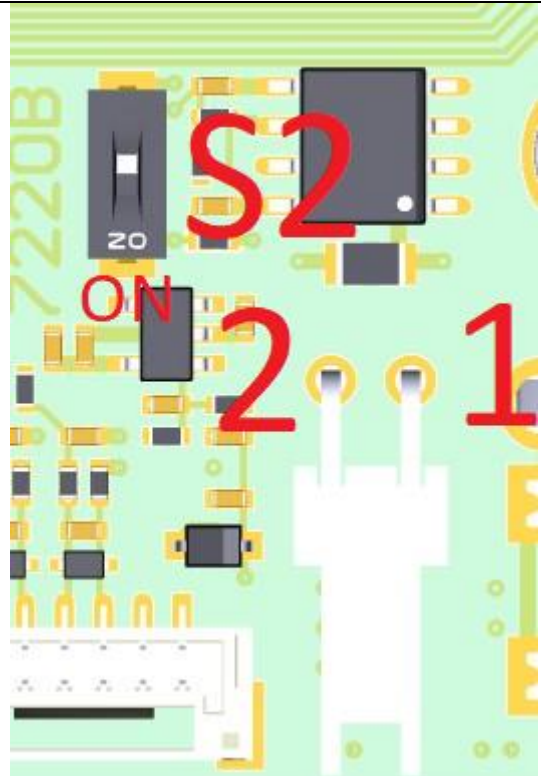
Interlock Connector X8		
	Pin	To enable the LDD apply a voltage between the Interlock + and Interlock – Pins. The Interlock Pins are galvanically isolated from the LDD. The DIP-Switch S2 can be switched ON to disable the Interlock functionality
	1	Interlock +
	2	Interlock –
	Mating connector	Molex 0022013027

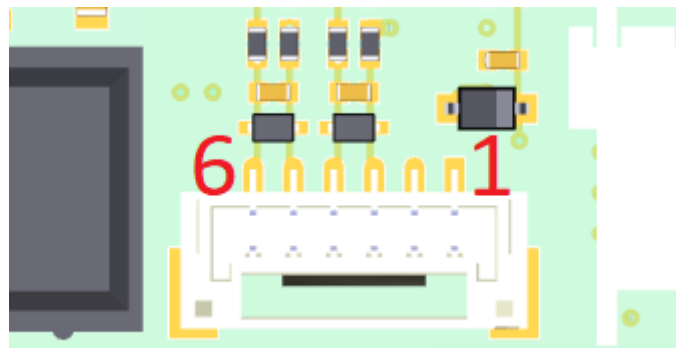
Temperature and Light Measurement connector X9			
		Mating Connector: JST GHR-06V-S	
Pin		Pin	
1	Photo Diode Anode	4	NTC 2 B
2	Photo Diode Cathode	5	NTC 1 A
3	NTC 2 A	6	NTC 1 B

Mounting holes Position

The four holes in each corner can be used to mount the device onto a heatsink. Hole diameter =3.2mm.
A 3D model of the device is available on our website.

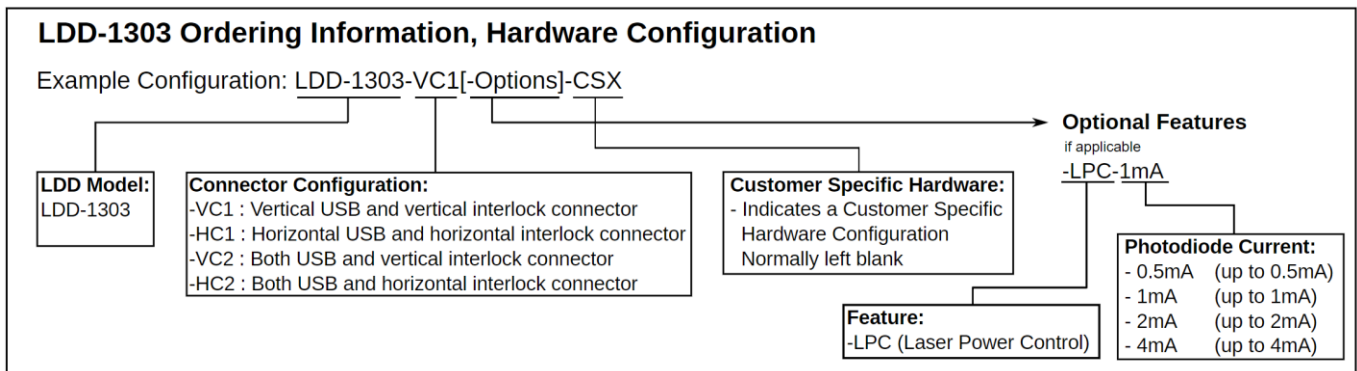
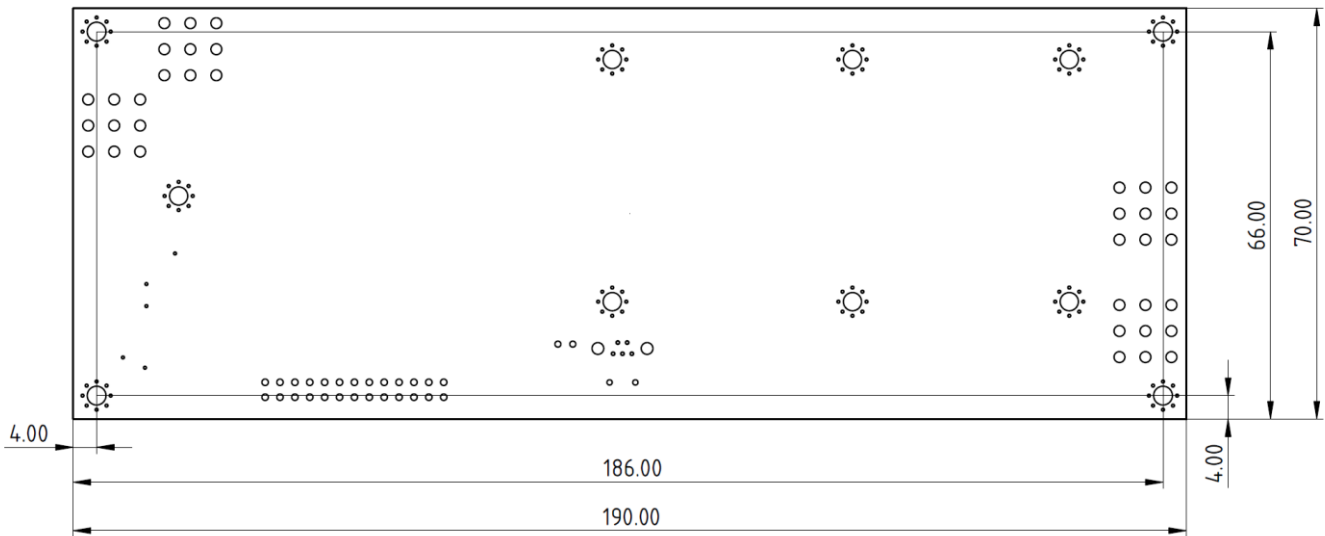

Laser diode, temperature probes, power supply and connectors not included.

Current-Controlled Operation-Modes and Communication Option

The LDD-1303 is an OEM high performance current source that is primarily designed to operate in CW mode. It is configured over an industry-standard RS485, RS232 TTL or a USB connection, either GUI-driven using the included LDD Service Software, or by direct parameter control using the predefined communication protocol. Basic system status is visually indicated by on-board LEDs, more detailed status information can be polled at any time. The LDD-1303 can operate in a stand-alone configuration as well as in a remotely controlled manner, with parameters adjusted on the fly. The laser diode driver is current-PID-controlled.

Configuration parameters further include: Control source selection, maximum current limits, nominal current ramping, PID controller settings, NTC temperature sensor modeling coefficients, measurement circuitry calibration, error thresholds, etc. Please refer to the user manual for further information.

Meerstetter Engineering GmbH
Schulhausgasse 12
3113 Rubigen, Switzerland



Phone: +41 31 529 21 00
Email: contact@meerstetter.ch
Website: www.meerstetter.ch

Meerstetter Engineering GmbH (ME) reserves the right to make changes without further notice to the product described herein. Information furnished by ME is believed to be accurate and reliable. However typical parameters can vary depending on the application and actual performance may vary over time. All operating parameters must be validated by the customer under actual application conditions.

Change History

Date of change	Doc/Version	Changed/Approved	Change/Reason
12 January 2022	B	LS	Add Change History
		LS/RK/ML	Review, small changes (types, format)
		RK/HS	Release
21 April 2022	C	XF/HS	Fix document formatting errors
		HS/PV	Edit minimum compliance voltage
		RS/HS	Edit compliance/output voltage text for clarity
		HS/RS	Remove redundant efficiency figures
19 July 2022	D	RS/CU	Photodiode input now specified through LPC options, new configurations available Photodiode input is only available with the LPC Option Temperature coefficient and current accuracy added
19 July 2022	E	CU/RS	Hardware version increased to v1.20 Formatting