

User Manual – LDD-130x

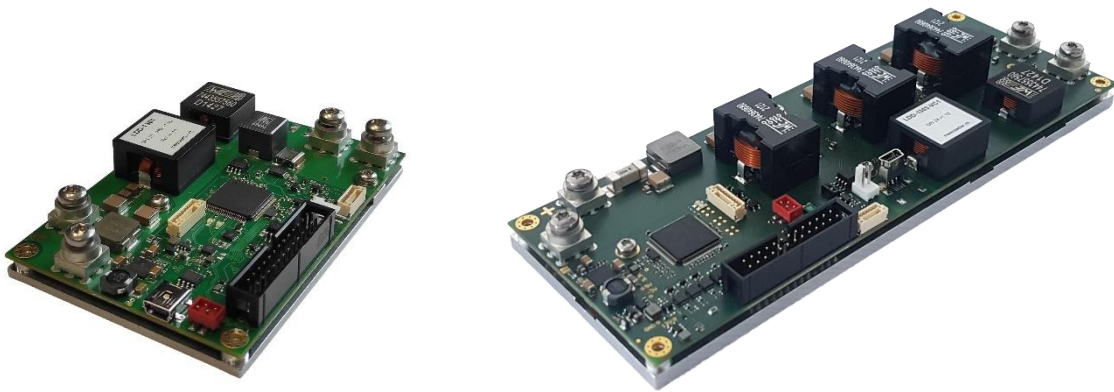

LDD-130x:

LDD-1301

LDD-1303

**meerstetter
engineering** 

 Member of Berndorf Group



Developed, assembled, and tested in Switzerland

Index

1	Introduction.....	4
1.1	Important Documents	4
1.2	How to Contact Support.....	4
2	Basic Functions	5
2.1	The Status Bar of Service Software	5
2.2	Remote Control Options	8
2.3	Firmware Updates	9
3	Operating the Current Driver	10
3.1	Theory of Operation.....	10
3.2	Driver Settings.....	11
4	Operating the Light Power Controller.....	13
4.1	Theory of Operation.....	13
4.2	Controller Settings	14
5	Temperature/Light Measurement and Analog Interfaces	16
5.1	Temperature Measurement	16
5.2	Light Measurement.....	17
5.3	Voltage Output	19
5.4	Voltage Input	20
6	Data Logging	21
6.1	Monitor Data Logger	21
7	External Hardware	22
7.1	GPIO Control Signals	22
8	Special Functions	24
8.1	Parameter Handling.....	24
9	Troubleshooting and Errors	26
9.1	Quick Reference.....	26
9.2	Error Numbers, Instances and Parameters.....	27
A	Change History.....	30

Meerstetter Engineering GmbH

Schulhausgasse 12

CH-3113 Rubigen

Switzerland

Phone: +41 31 529 21 00

Email: contact@meerstetter.ch

Meerstetter Engineering GmbH (ME) reserves the right to make changes without further notice to the product described herein. Information furnished by ME is believed to be accurate and reliable. However typical parameters can vary depending on the application and actual performance may vary over time. All operating parameters must be validated by the customer under actual application conditions.

Document 5261D

LDD-130x Firmware Version v1.30

Release date: 12 September 2022

1 Introduction

This manual covers the functionality of the LDD-130x digital (laser) diode drivers.

Most of the explanations in this document assume that you use the “LDD-130x Service Software”, but all the operations can also be done by your own application if you implement the functionality. Most of the commands are documented in our communication protocol documents.

If you cannot find the feature or setting you need, please do not hesitate to contact our support. We do also provide customized firmware solutions.

1.1 Important Documents

- [Datasheets](#)
 - Technical specifications
 - Hardware configurations
 - Ordering information
- [LDD-130x Communication Protocol](#)
 - Protocol specification
 - Commands, Parameters
 - Example Applications and [APIs](#)
- [Temperature & Light Sensor Cable Specifications](#)
 - Pinout
 - Temperature sensor and photodiode assembly
- [Temperature Sensor Suggestions](#)
 - Description, part numbers and distributors for NTC sensors
- [Application Notes](#)
 - Additional Information about various usages of our devices

1.2 How to Contact Support

For optimal technical assistance we need the following information:

- Configuration file, exported while the error is present
 - Click “Export Config” in the footer
- Monitor History
 - Click “Maintenance” tab” → “Monitor Data Logger” → activate Checkbox “Export all Monitor Values to CSV File (Debug)” → “Export Logged Monitor Data to CSV File”
- A picture showing your system, the controller and the sensor leads.
- Datasheets of your Peltier element, power supply and any other important parts involved in your setup.

You can also use the [TeamViewer software from our website](#) for a remote-control session. As soon as you start the tool we will recognize you, but please make sure to call or write us beforehand.

2 Basic Functions

2.1 The Status Bar of Service Software

The bottom row of the software is always visible and shows the following information:

- Connection status
- Device status
 - Ready: Normal standby status (no errors). Output stage disabled
 - Run: Normal operating status (no errors). Output stage enabled
 - Error: Error occurred. Output stage disabled
 - Bootloader: Firmware is being updated
- Operating parameters
 - Output current and voltage

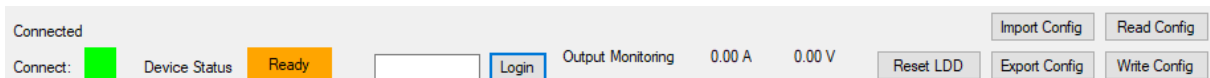

Figure 1. Status bar in the bottom row of the Service Software.

2.1.1 Status LEDs and Service Software Status

LDD-130x devices feature two status LEDs. In normal operation, the green LED is blinking.

In the case of any error occurring, the device enters an error status and the red LED is lit. Power circuitry (output stage) is immediately deactivated to ensure safety. Control, monitoring and communication circuitry remains active. In case of software / configuration errors (i.e. not hardware faults), parameters can be reconfigured on the fly. The device needs to be software-reset or power-cycled to clear the error status.

Table 1. Status LED description.

Green LED	Red LED	Signification
Blinking slowly (~1 Hz)	-	“Ready” status (no errors). Output stage disabled
Blinking fast (~2Hz)	-	“Run” status (no errors). Output stage active
-	Static on	“Error” status. Output stage disabled
Static on	Static on	“Bootloader” status

When the Service Software is connected to a device, its status is displayed in the bottom of the software window.

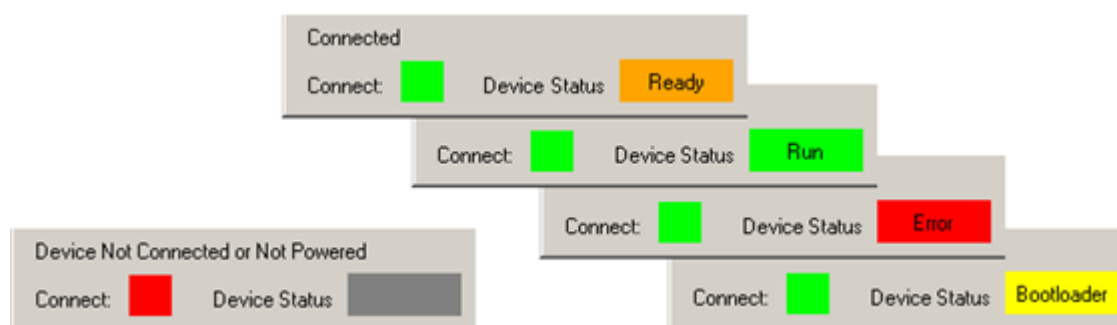

Figure 2. Service Software color codes for connection and device status.

Error Status:

If the device enters the error status, please go to the “Monitor” tab, there you can find the error number and description on the right side of the window.

Alternatively, you can find a list of all errors at the end of this User Manual.

2.1.2 Writing and Reading Device Parameters

Changed parameters are saved to the controller by clicking “Write Config” in the footer. Multiple parameter fields can be written at once. Be aware that also fields in tabs which are not currently displayed are written to the controller.

Parameters are read automatically when a connection to the controller is established.

2.1.3 Importing and Exporting .ini Configuration Files with the Service Software

Device configuration sets can be exported as backup or for support purposes. They are specific to each unit as they contain calibration data.

- Export
 - To save a configuration file on the PC, click on “Export Config” in the bottom right corner of the Service Software.
 - All actual values are also stored. The values are useful for support and analysis.
- Import
 - To load a configuration file from the PC, click on “Import Config” in the Service Software.
 - By default, calibration data is only imported when the serial number in the configuration file matches the connected device’s serial number (this option can be disabled in the relevant tabs at the bottom).

2.2 Remote Control Options

This is an overview of the different remote-control options for the device. It's possible to configure, control and monitor the device using any software which can communicate over an appropriate interface. In the "[LDD-130x Communication Protocol 5260](#)" document a list of the software options available from us can be found.

Generally, all parameters available in the Service Software can be read and written by other means using the communication protocol.

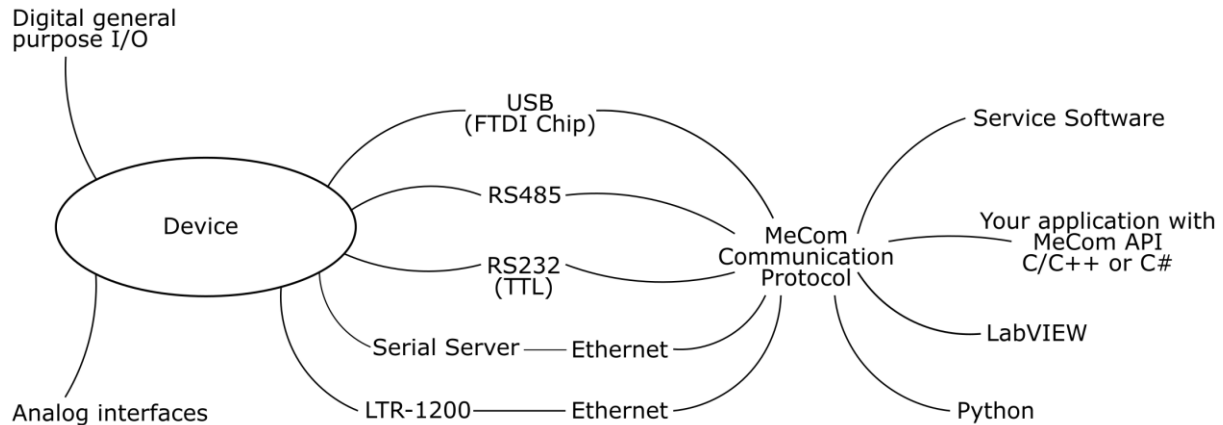

Figure 3. Remote control options.

2.2.1 Serial Communication

Serial communication is used to send data from a host to an LDD-130x and receive data from the device, respectively. The following physical interfaces are supported:

- USB
- RS485 (check out our [TEC Application Note - RS485 Interface](#), valid for LDD-130x too)
- RS232 TTL¹

Communication using the Service Software and RS485 is only possible using a USB–RS485 adapter or an Ethernet serial server, since the Service Software only connects to FTDI² chips or TCP port 50'000.

2.2.1.1 Addressing specific devices

Assign a unique “Device Address” to the device if multiple devices are operated on the same bus. The “Device Address” can be set on the “Operation” tab when the Service Software has already connected to the device. You can then tell the Service Software to use a specific device address to communicate. To do this, open the “Maintenance” tab and look for “Service Communication Settings”. For more application arguments, check our communication protocol document. All devices have a 1-unit load receiver input impedance, allowing up to 32 transceivers on the RS-485 bus.

2.2.2 Ethernet Communication

It's possible to use a standard Serial Server to connect our devices to an Ethernet interface. We have tested devices from Lantronix (e.g. XPort, UDS1100) and Moxa (e.g. NPort 5130). Please check [TEC Application Note - RS485 Interface](#), valid for LDD-130x devices too.

¹ Availability dependent on device.

² One option is the [USB RS485 converter cable from FTDI Chip](#), available in different lengths.

2.3 Firmware Updates

You can [download the firmware \(contained in the software package\)](#) from our website and update your devices using the Service Software.

The Service Software and the Firmware are strongly related. Only when a Service Software and a Firmware with a matching Version Number are used the full functionality can be guaranteed. However, it is usually possible to connect to a device with an old Firmware with a new Service Software and vice-versa. Functionality will be limited, but firmware updates are possible.

Matching version numbers: All our published software has a version number similar to this: "vX.YZ". It is important that at least X and Y is matching. Z can be different.

Follow these steps to update devices:

- Read the [LDD-130x Software Release Notes](#)
- Backup the current configuration. This is important because it is possible that the current configuration will be lost during the update.
- In the tab "Maintenance" locate "Device Boot Loader".
- If the *.msi* installation package has been used, the correct hex file is already selected, otherwise
 - Click to browse and choose the new *.hex* file
- Click to "Update"
- The device will reboot once the update completes.
- You can check the firmware version in the tab "Monitor".
- Re-import the before exported *.ini* file (if necessary).
- Fill missing parameter values into new parameter fields (if applicable).

3 Operating the Current Driver

3.1 Theory of Operation

LDD-130x devices feature an output current stage controlled by a PID Controller implemented in the microcontroller.

The devices differentiate themselves in their capabilities. For technical reasons, the position of the current measurement differs, as shown in the diagrams. As a consequence, while in the LDD-1301 the cathode is connected to the board's ground, in the LDD-1303 the cathode also needs to be floating.

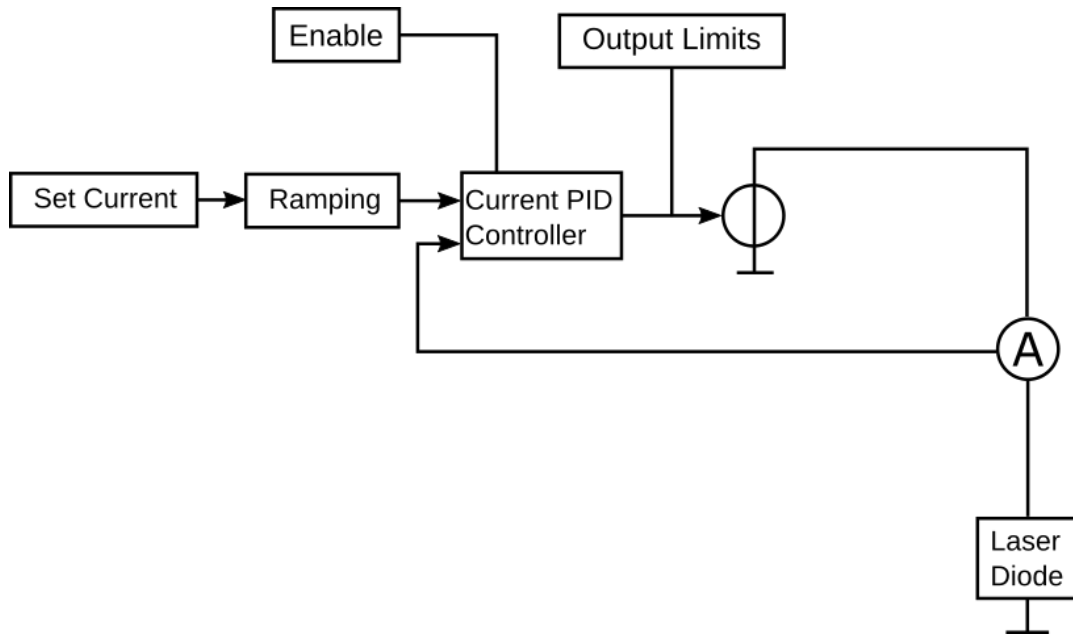

Figure 4. Functional overview of the LDD-1301.

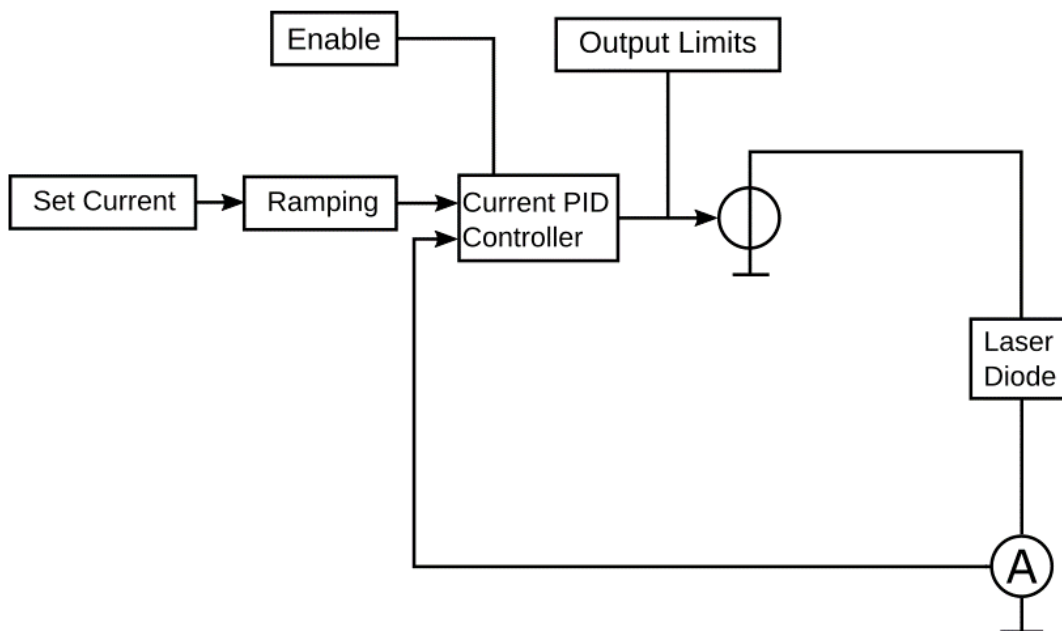

Figure 5. Functional overview of the LDD-1303.

3.2 Driver Settings

3.2.1 Output Settings

In the tab “Operation” you can set the Nominal Output Current to be controlled from four sources:

- a normal parameter saved to flash (“Set Current”),
- a volatile parameter saved in RAM only (“Volatile”),
- from the light power control feature³ (“LPC”),
- from the analog input feature⁴ (“Analog”).

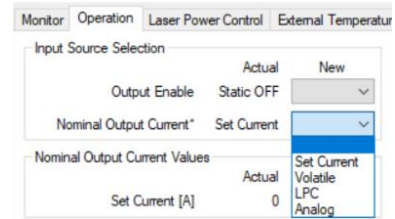

Figure 6. Output Current Selection.

The output is activated by “Output Enable”. This setting is saved to the flash and remains active after a power cycle or reset.

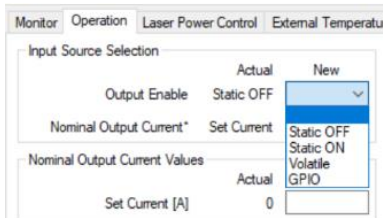

Figure 7. Output Enable Selection.

- In “Static OFF” mode, the enable status is set to disabled.
- In “Static ON” mode, the enable status is set to enabled.
- In “Volatile” mode, the enable status is read from a volatile parameter, which returns to 0 after a reset.
- In “GPIO” mode, the enable status is read from a user-defined GPIO.

The output stage nominal current limit settings allow to define limits for the nominal current that will be enforced regardless of the current you set. These should be set to reflect the normal operation range.

The error thresholds are important safety settings which when crossed, will cause the device to go into error mode and consequently shut down its output stage. You should set these in order to protect your connected diode from regulation or configuration issues. This value should always be set within the absolute maximum current rating of the laser diode you’re using.

Output Stage Limits		Actual	New
Max Nominal Current [A]	20		
Min Nominal Current [A]	0		
Current Error Threshold [A]	21		
Voltage Error Threshold [V]	46		

Figure 8. Output Stage Limits.

³ See the relevant chapter for how to set up the light power control

⁴ See the relevant chapter for how to set up the analog input control

3.2.2 Current Controller Settings

These settings, again in the tab “Operation”, define the behavior of the current regulation. The current-stage is regulated by a PID controller.

Current Controller Settings		
	Actual	New
PID K_p [%/A]	0.1	<input type="text"/>
PID T_i [s]	0.001	<input type="text"/>
PID T_d [s]	0	<input type="text"/>
Slope Limit [A/s]	10	<input type="text"/>

Figure 9. Current Controller Settings.

The proportional term K_p defines the portion [%] of available current that is used to correct the difference [A] between actual and nominal CW current.

The integral term T_i defines the reset time [s] the regulator is allowed to take for correcting a given control deviation. The effect of T_i is weak for large values and strong for small values.

The derivative term T_d opposes changes in control deviation, weighed by unit time [s]. The dampening effect of T_d increases with larger values (e.g. a value of 0 results in bypassing the D component).

The “Slope Limit” acts on internal nominal current ramping and allows the use of more aggressive PID settings.

The “Laser Diode Characteristics” provide the controller with a model of the load, in order to improve the regulation.

4 Operating the Light Power Controller

4.1 Theory of Operation

LDD-130x devices feature an optional cascaded PID Controller to control the emitted light power of laser diodes. This control is also implemented in the microcontroller.

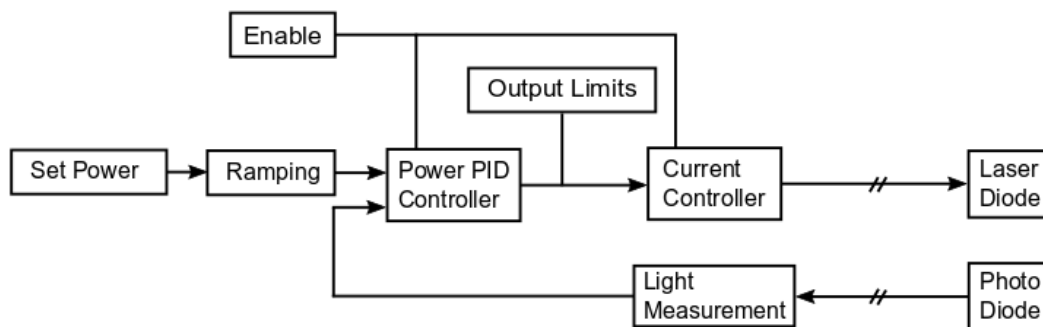

Figure 10. Functional overview of the light power control on LDD-1301/1303.

4.2 Controller Settings

4.2.1 Output Settings

In the tab “Operation” the Nominal Output Current can be set via the normal parameter (“LPC”), meaning the light power PID controller’s output is connected to the input of the PID controller of the current driver.

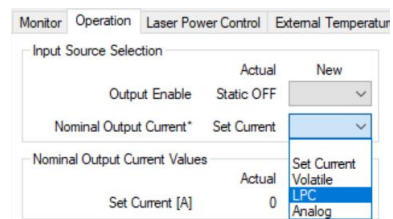

Figure 11. LPC selection.

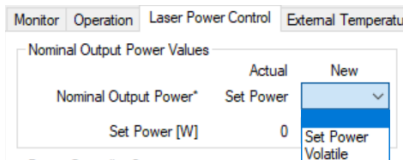

Figure 12. Output Power selection.

In the tab “Laser Power Control” the Nominal Output Power can be controlled either over the normal parameter (“Set Power”, saved to flash) or over the volatile (RAM) parameter.

The output is activated by “Output Enable”. This setting is saved to the flash and remains active after a power cycle or reset.

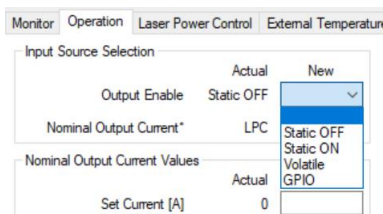

Figure 13. Output Enable selection for LPC.

- In “Static OFF” mode, the enable status is set to disabled.
- In “Static ON” mode, the enable status is set to enabled.
- In “Volatile” mode, the enable status is read from a volatile parameter, which returns to 0 after a reset.
- In “GPIO” mode, the enable status is read from a user-defined GPIO.

The output stage nominal power limit settings allow to define limits for the nominal light power that will be enforced regardless of the light power you set. These should reflect your target operation range.



Figure 14. Output Stage Limits for LPC.

4.2.2 Power Controller Settings

These settings, again in the tab “Laser Power Control”, define the behavior of the light power regulation. The current stage is regulated by a PID Controller that is regulated by a cascaded PID Controller.

Power Controller Settings		
	Actual	New
PID K_p [%/W]	0.25	<input type="text"/>
PID T_i [s]	0.01	<input type="text"/>
PID T_d [s]	5E-06	<input type="text"/>
Slope Limit [W/s]	10	<input type="text"/>

Figure 15: Power Controller Settings for LPC.

The proportional term K_p defines the portion [%] of available light power that is used to correct the difference [W] between actual and nominal CW light power.

The integral term T_i defines the reset time [s] the regulator is allowed to take for correcting a given control deviation. The effect of T_i is weak for large values and strong for small values.

The derivative term T_d opposes changes in control deviation, weighed by unit time [s]. The dampening effect of T_d increases with larger values (e.g. a value of 0 results in bypassing the D component).

The “Slope Limit” acts on internal nominal light power ramping and allows the use of more aggressive PID settings.

5 Temperature/Light Measurement and Analog Interfaces

5.1 Temperature Measurement

This input can accommodate NTC sensors.

Error thresholds to protect your load against overheating are available in the “External Temperature” tab. They can be activated via the setting in the “External Temperature Errors Enable” box. The error limits can be set for each input in the “External Temperature Error Limits” box.

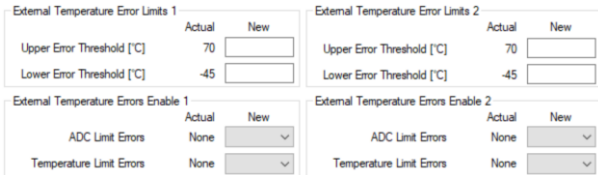

Figure 16. External Temperature Error Settings.

If the “ADC Limit Errors” are enabled, an error will be thrown if the NTC sensor has reached a resistance value that is at the edge of the measurable range of the controller. It offers a selection of different threshold detections, one for only the upper value, another only for the lower value and one for both.

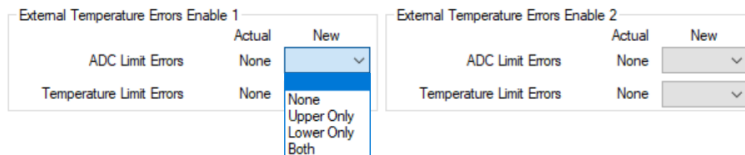

Figure 17. External Temperature Errors Enable for ADC Limit Errors.

If the “Temperature Limit Errors” are enabled, the crossing of the thresholds set in “External Temperature Error Limits” will be detected and cause an error. It offers a selection of different threshold detections, one for only the upper value, another only for the lower value and one is for both.

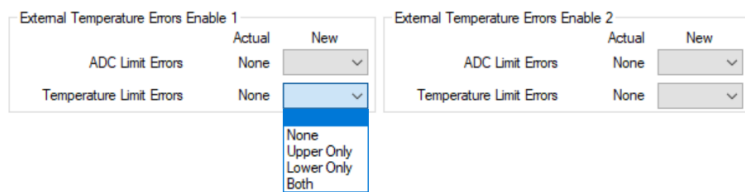

Figure 18. External Temperature Errors Enable for Temperature Limit Errors.

The “External Temperature Measurement Settings” allow an additional user calibration for each input.

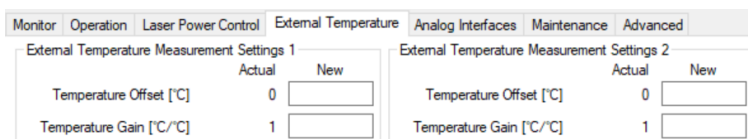

Figure 19. External Temperature Measurement Settings.

The “External Temperature Measurement Limits” are calculated values showing the range of measurable resistance of the input. The corresponding maximum and minimum temperatures are calculated for each temperature input using the sensor characteristic found in tab “Advanced” > “External Temperature Measurement”, in “External NTC Sensor Characteristics”.

The screenshot shows the 'Advanced' settings tab with the following sections:

- External Temperature ADC Calibration 1:** Offset: 10.66698, Gain: 1.003596.
- External Temperature ADC Calibration 2:** Offset: 35.22087, Gain: 1.004143.
- External NTC Sensor Characteristics 1:**
 - Upper Point: Temperature [°C] = 60, Resistance [Ω] = 2488
 - Middle Point: Temperature [°C] = 25, Resistance [Ω] = 10000
 - Lower Point: Temperature [°C] = 0, Resistance [Ω] = 32650
- External NTC Sensor Characteristics 2:**
 - Upper Point: Temperature [°C] = 60, Resistance [Ω] = 2488
 - Middle Point: Temperature [°C] = 25, Resistance [Ω] = 10000
 - Lower Point: Temperature [°C] = 0, Resistance [Ω] = 32650

Figure 20. External NTC Sensor Characteristics settings.

5.1.1 Temperature Correction of the Output

In the “Advanced” > “Temperature Correction” tab you can activate a temperature-dependent contribution to the set current.

The screenshot shows the 'Temperature Correction Settings' section with the following parameters:

- Source*:** Disabled (dropdown menu)
- Offset* [°C]:** 0
- Gain* [A/°C]:** 0

Figure 21. Temperature Correction Settings.

This can be used to compensate variations in the light output of your laser due to temperature variations, in the absence of optical feedback. The Gain and Offset parameters are used in the following formula:

$$I = I_{set} + \text{Gain} \cdot (T - \text{Offset})$$

Where T is the temperature input you selected via Source, I_{set} is the nominal current you set as when using the controller normally, and I is the actual nominal current that the LDD will follow. This final value can be observed in the Monitor tab as the “Nominal Output Current (Ramp) [A]” parameter.

Internal Parameters	
Volatile Output Enable	0
Volatile Nominal Output Current [A]	0.00
Nominal Output Current (Ramp) [A]	0.00
Output Level [%]	0.000
Calculated Input Current [A]	0.00
Calculated Output Current [A]	0.00

Figure 22. Monitor Value of the Nominal Output Current (Ramp).

5.2 Light Measurement

The optional light measurement input offers the possibility to observe the photodiode current via a parameter shown on the Monitor tab (Figure 24). In absence of the feature the value will be stay on NA.

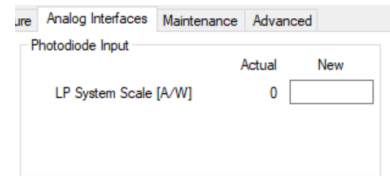

Figure 23. Light Power Factor.

Through the parameter “LP System Scale” LP_{Gain} (Figure 23), the conversion factor to translate the photodiode current I_{Ph} into an emitted light power P_{Light} , can be defined, this is required for operating with the light power control. This parameter depends on the photodiode and the optical coupling of the system. You can set this arbitrarily in the absence of an absolute reference measurement.

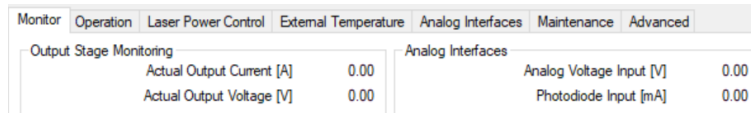

Figure 24. Monitor value of the Photodiode Input.

$$P_{Light} = \frac{I_{Ph}}{LP_{Gain}}$$

The above formula shows the relationship between the emitted light power and the photodiode current LP_{Gain} . The value is also displayed in the Monitor tab.



Figure 25. Monitor value of the Emitted Light Power.

5.2.1 Photodiode Input Setting

In the tab “Advanced” > “Analog Interfaces” you can set a resistance value for the photodiode input. Note that “Photodiode Rs” depends on the LPC hardware configuration and does not need to be modified by the end user.

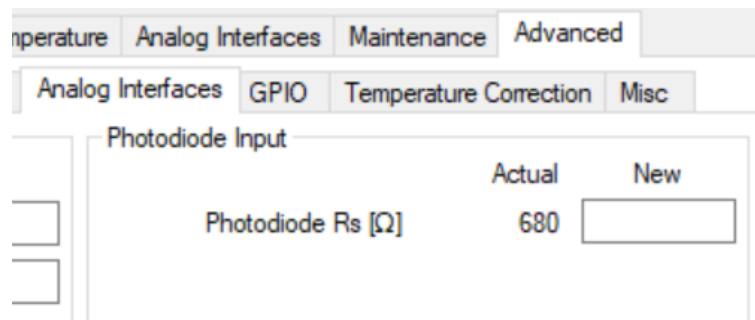

Figure 26. Photodiode Input setting.

The values correspond to each LPC configuration according to the following table:

Photodiode Rs [Ω]	LPC Configuration [mA]
5600	0.5
2700	1
1300	2
680	4

Table 2. LPC configurations.

5.3 Voltage Output

The voltage output (tab “Analog Interfaces”) can be used to provide a synchronization output (i.e. a voltage signal with the same waveform as the measured output current) or a voltage signal controlled by the “Set Value [V]” parameter. Configure the “Signal Source” to select between those two modes.

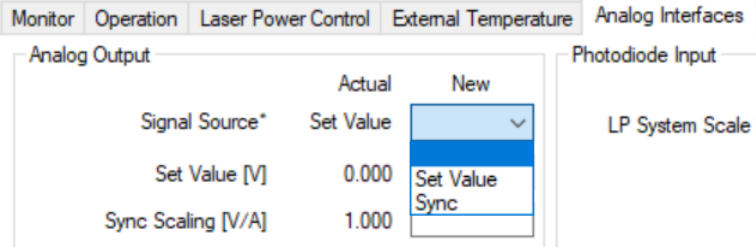

Figure 27. Analog Output settings.

This output runs with a frequency of 10 Hz.

“Sync Scaling [V/A]” allows to set the output current to output voltage ratio.

5.4 Voltage Input

The analog voltage input is displayed in the “Monitor” tab (Figure 29). To control the output current through this analog input, the Nominal Output Current in the tab “Operation” can be set to “Analog” (this needs to be followed by a reset).

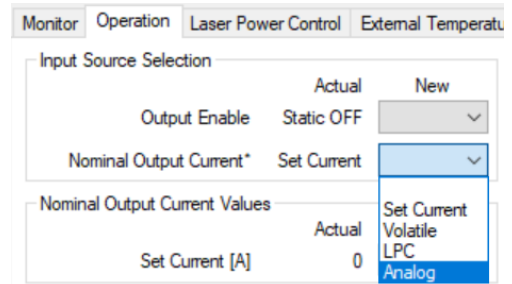

Figure 28. Output Current Setting for Analog Input.

Monitor	Operation	Laser Power Control	External Temperature	Analog Interfaces	Maintenance	Advanced
Output Stage Monitoring				Analog Interfaces		
Actual Output Current [A]		0.00		Analog Voltage Input [V] 0.00		
Actual Output Voltage [V]		0.00		Photodiode Input [mA] 0.00		

Figure 29. Monitor value of the Analog Voltage Input.

The output current set by the Analog Input follows the formula below where I is the output current, $V_{AnalogIN}$ is the input voltage and G is the scaling factor “Current Factor [A/V]”

$$I = V_{AnalogIN} \cdot G$$

The Current Factor parameter is used to convert the Analog Input Voltage into a corresponding Output Current and can be found in the tab “Analog Interfaces”, in the “Analog Input” box.

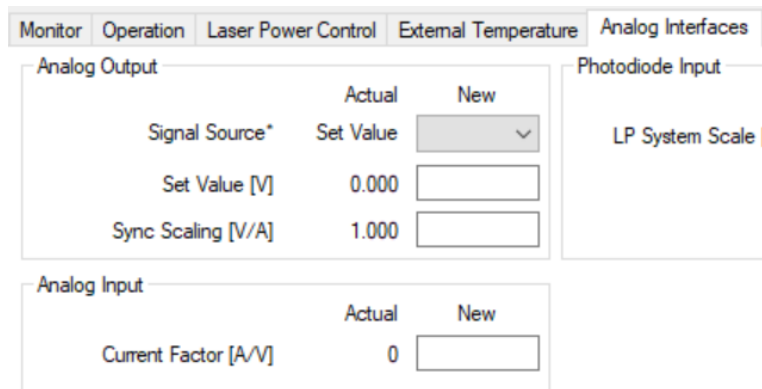
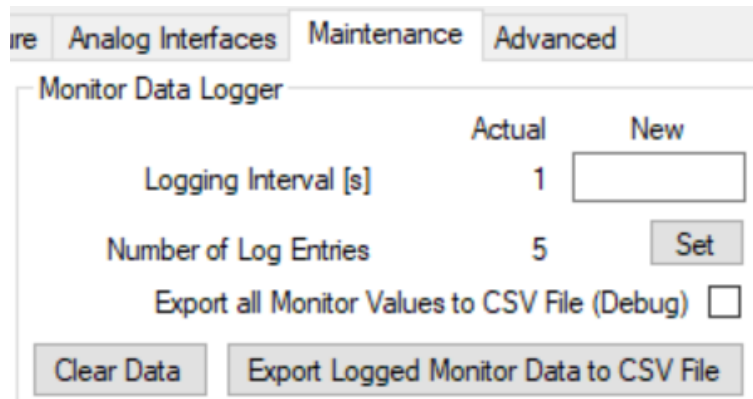

Figure 30. Analog Input Setting.

6 Data Logging

6.1 Monitor Data Logger

For external plotting and data analysis, logged data can be exported to a .csv file, in the “Maintenance” tab in the box “Monitor Data Logger”.



The screenshot shows a software interface with four tabs: "ire", "Analog Interfaces", "Maintenance", and "Advanced". The "Maintenance" tab is selected. Inside this tab, there is a section titled "Monitor Data Logger". It contains the following elements:

	Actual	New
Logging Interval [s]	1	<input type="text"/>
Number of Log Entries	5	<input type="button" value="Set"/>
Export all Monitor Values to CSV File (Debug)		<input type="checkbox"/>

At the bottom of the "Monitor Data Logger" section, there are two buttons: "Clear Data" and "Export Logged Monitor Data to CSV File".

Figure 31. Monitor Data Logger.

- Each log entry is time stamped.
- At relaunch of the software the log is erased and the log interval is set to the smallest value of 1 s.
- The general data logging duration is not limited. It depends on the available RAM on the PC and the logging interval.
- For critical long-term monitoring we recommend exporting the log regularly and to relaunch the Service Software occasionally (e.g. every couple of days).
- The exported file of the logged data contains the value of various monitor parameters such as the output current.
- Select “Export All Monitor Values to CSV File (Debug)” to export more values, which can be useful if you send the file to Meerstetter for diagnosis.

7 External Hardware

7.1 GPIO Control Signals

The GPIO control signals can be used for general purpose I/O (GPIO) or for predefined functions. The functions described in Table 3 can be independently assigned to the GPIO signals in the “Advanced” → “GPIO” tab. Many functions are separately available as several channels. For those functions, the channel can be chosen in the “Advanced” → “GPIO” tab as well. For the functions which are not available in multiple instances this setting has no effect.

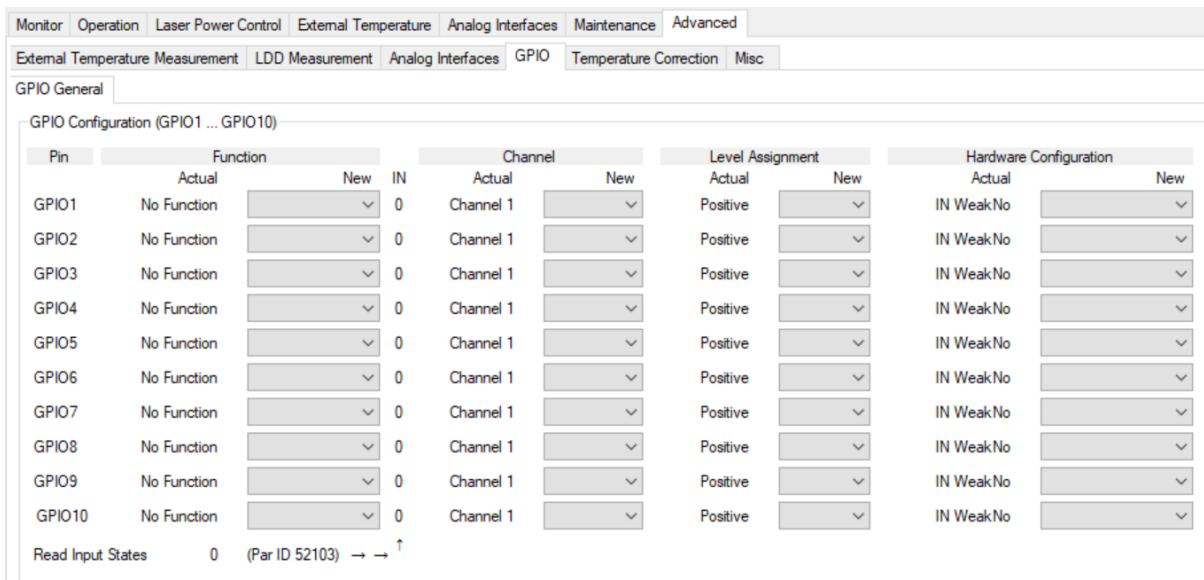

Figure 32. GPIO settings.

Table 3. Available functions for the GPIO signals.

Function Name	Description
No Function	The GPIOx has no function. The pin is at high impedance state.
Signal Control	The GPIOx signal is used as digital I/O, controlled by the communication interface. Refer to the communication protocol document for more information.
LDD OK	The GPIOx signal is logic 1 if the device is in the “Ready” or “Run” status.
HW Enable	The GPIOx signal is used as input to enable the output of the driver. In the “Operation” tab select “GPIO” as “Output Enable” source. If the signal is logic 1, the driver output is enabled.
LDD Run	The GPIOx signal is logic 1 if the device is in the “Run” status.
Dev Adr +1 Dev Adr +2 Dev Adr +4	The GPIOx signal is used as input signal. For each pin which is logic 1 and with this function enabled, 1, 2 or 4 is added to the device address. This is only done once at startup.
Pulse Input	When this pin is logic 0 the target current used by the current control loop is set to the Value of “Min Nominal Current”. When the pin is logic 1, the target current is left unaltered. (= Nominal Current) When multiple pins are configured as Pulse Input the GPIO with the highest number is used. If no GPIO is configured as Pulse Input the target current is left unaltered.

The Logic Level of each pin can be assigned under “Level Assignment” in the “GPIO” tab. For inputs, Logic Level “Positive” means that a high voltage is read in as logic 1 while a low voltage (Pin connected to GND) is logic 0. This can be inverted by setting the parameter to “Negative”. For outputs, the logic level inverts the Signal when set to “Negative”. This means that the “LDD OK” signal outputs 0V when the LDD is in “Ready” or “Run” status and the Level Assignment is set to “Negative”

The Pins can be Individually configured under “Hardware Configuration” in the “Advanced” → “GPIO” tab. When a signal is used as an input the hardware configuration must be made accordingly or the function will not be operational. The Hardware configuration is described in Table 4.

Table 4. GPIO Pins Hardware Configuration

Function Name	Description
In WeakNo	The GPIO Pin is configured as Input. No PullUp or PullDown Resistor is activated.
In WeakUp	The GPIO Pin is configured as Input. A weak PullUp Resistor to 3.3V of approximately 50kΩ is activated.
In WeakDown	The GPIO Pin is configured as Input. A weak PullDown Resistor of approximately 50kΩ is activated.
OUT PushPull	The GPIO Pin is configured as Push Pull Output. No PullUp or PullDown Resistor is activated.
OUT OD NoPull	The GPIO Pin is configured as an Open Drain Output. No PullUp or PullDown Resistor is activated.
OUT OD WeakUp	The GPIO Pin is configured as an Open Drain Output. A weak PullUp Resistor to 3.3V of approximately 50kΩ is activated.

For input signals like buttons, it is usually easier to set the pin to “Negative” logic and “In Weak Up”. This way the switch can be connected between the GPIO pin and GND.

8 Special Functions

8.1 Parameter Handling

8.1.1 Settings Dump (.mepar File) with the Service Software

In cases where many or all settings of a LDD-130x device are to be changed from a host software or a host microcontroller, a settings dump function is available. This generates a file which can be dumped to a LDD-130x using third party host systems.

- Every parameter which is labeled with “New”, that contains information will be stored in the .mepar file.
- In the “Maintenance” tab click “Create File” in the box “Create *.mepar file (for Settings Dump)”.

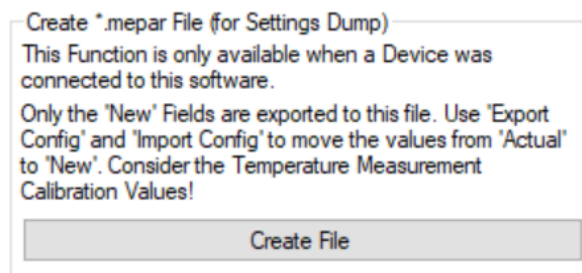

Figure 33. Settings Dump.

- For every parameter stored in the .mepar file, a line contains the parameter string that is specific to function, firmware and device type.
- Using the MeCom communication protocol, the .mepar file can be sent line-by-line to one or several devices. These batch configurations will immediately become active.
- It is also possible to download just one single setting (i.e., one line of the .mepar file) directly from the Service Software to a device.
- Copy a line from the file and paste it in the field. Click “Send String”.

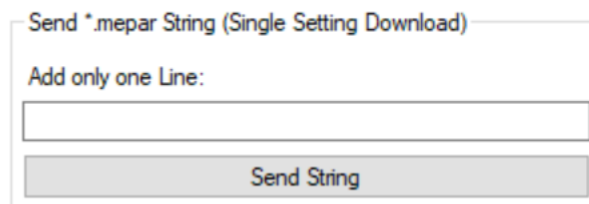

Figure 34. Single Setting Download.

8.1.2 Parameter System Save to Flash Configuration (Save Data to Flash)

See tab "Advanced" → "Misc".

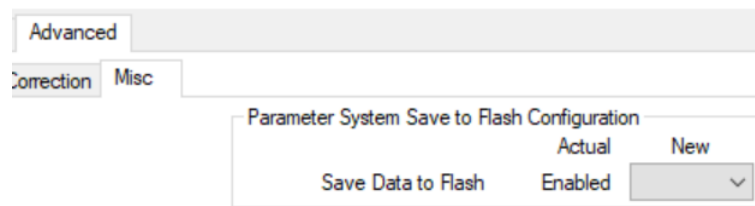

Figure 35. Flash Configuration.

Table 5. Settings saving behavior.

Option	Options and Description
Enabled	Default setting. Every time a parameter is changed a 0.5 s delay timer is started. After expiration, all changed data is saved to the non-volatile flash.
Disabled	Saving data to the non-volatile flash is disabled. This is useful when the device is connected in a bus system, where parameters are changed regularly. This prevents early failure of the flash memory due to frequent rewrites.

9 Troubleshooting and Errors

9.1 Quick Reference

Table 6. Typical Problems

Problems	Possible Reason	Possible Solution
The Service Software is not starting	The Service Software does not work with 64-bit versions of Microsoft Visual C++ 2015 Redistributable Package	Make sure that the correct version (32-bit) of Microsoft Visual C++ 2015 Redistributable Package is installed.
The output is suddenly switched off	An error happened.	Check the error message in the "Monitor" tab.
The firmware is too old	The firmware is too old to connect to the Service Software.	Please update the firmware as described in 2.3 Firmware Updates .
Error 105 shows up while the output current is rising.	1303: The input voltage is insufficient to reach the voltage necessary to drive the set current. 1301: Possibly Hardware Damage	Check if the voltage requirements on the datasheet are respected and ensure that the output power of your supply is sufficient to avoid voltage drops.
Error 103	<ul style="list-style-type: none">• The input voltage is insufficient.• The PID controller is set up too aggressively or incorrectly	
Error 102	Load with too low compliance voltage is used or short-circuit at output.	Check Load for short-circuit or load with higher compliance voltage.

9.2 Error Numbers, Instances and Parameters

- Error Numbers from 1 through 99, excluding 30 through 39, designate error conditions that are universal across the whole range of Meerstetter TEC Controllers and laser diode drivers.
Error numbers starting from 100 designate conditions that are specific to LDD-130x devices (see tables below).
- Error Instance can designate the involved instance of a functionality or be useful information for Meerstetter Engineering technical support.
- Error Parameters are additional information to help Meerstetter Engineering technical support in the processes of error diagnosis or remote debugging.

9.2.1 Error Numbers 1 – 99 (universal)

Table 7. Processor Errors

#	Description	Error Condition
1 – 10	MCU system malfunction	-

Table 8. HMI Errors

#	Description	Error Condition
11	Emergency stop was triggered by LTR-1200	-
12	LTR-1200 HMI regularly sends 'free' signals to all rack-internal devices such that they can activate their output stages (if enabled)	No signal received for more than one second

Table 9. Parameter System Errors

#	Description	Error Condition
20-21	Internal parameter system malfunction	-
22	Parameter set corrupt	Configuration flash empty or defect (fix: see error #23)
23	Parameter set incompatible with current firmware version	Load .ini file saved prior to FW update, or Default.ini
24	Firmware does not recognize valid device	-
25	Internal parameter system malfunction	Access to a non-existing instance
26	Internal limit system malfunction	-
27	Parameter write or read wrong datatype function used	-
28	Parameter write value out of range	-
29	Parameter save to flash called from interrupt	-

Table 10. Power Supply Errors

#	Description	Error Condition
30	Input voltage net too low	< 10.5 V
31	Input voltage net too high	> 55 V
32	Internal 12 V power net too low	< 10.7 V
33	Internal 12 V power net too high	> 13.5 V
34	Internal 5 V power net too low	< 4.7 V
35	Internal 5 V power net too high	> 5.25 V
36	Internal 3.3 V power net too low	< 3.1 V
37	Internal 3.3 V power net too high	> 3.5 V
38	Internal -5 V power net too low	< -6 V
39	Internal -5 V power net too high	> -4 V

Table 11. Flash Memory Errors

#	Description	Error Condition
50	On-board flash failure	Write Timeout
51	On-board flash failure	Erase Timeout
52	On-board flash failure	Invalid Address

Table 12. Communication (UART) Error

#	Description	Error Condition
53	Send buffer overflow error	-

Table 13. Device Temperature and Hardware Errors

#	Description	Error Condition
60	Device running too hot	See datasheet.
61	Communication error with I/O hardware during factory test	-

9.2.2 Error Numbers 100 - ... (specific to LDD-130x devices)

Table 14. Power Output Errors

#	Description	Error Condition
100	Output overcurrent	> "Current Error Threshold"
101	Output overvoltage	> "Voltage Error Threshold"
102	PID lower limit error	Too long in lower limitation (0, 0.1 % margin) and Output current > 0.05 A
103	PID upper limit error	Too long in upper limitation (0.96, 0.1 % margin)
104	Fast switchoff output overcurrent error	Device overcurrent
105	Input overcurrent	> 57 A, > 500 ms
110	Interlock error	Interlock low

Table 15. Current Measurement Errors

#	Description	Error Condition
120	Phase current measurement offset too high.	-
121	Phase current measurement offset too low.	-

Table 16. Internal Power Stage Errors

#	Description	Error Condition
130	Excessive phase asymmetry	-
131	Measured and calculated output currents too different	-
132	Excessive balancing factor	-

Table 17. External Temperature Measurement Errors

#	Description	Error Condition
140	12bit ADC raw value below safety margin	< 40 (1%)
141	12bit ADC raw value above safety margin	> 4050 (99%)
142	Measured temperature too low	< "Lower Error Threshold"
143	Measured temperature too high	> "Upper Error Threshold"

Table 18. Various Errors

#	Description	Error Condition
183	No package has been received within the specified Watchdog timeout time	-

A Change History

Date of change	Version	Changed/ Approved	Change / Reason
20 December 2021	5261A	RS/HS	<ul style="list-style-type: none">• Initial Release
1 April 2022	5216B	HS/PV	<ul style="list-style-type: none">• Error 102 edited• Describe temperature correction function
29 August 2022	5261C	CU/RS	<ul style="list-style-type: none">• Describe the theory of light power control• Light Measurement edited
6 September 2022	5261D	CU/RS	<ul style="list-style-type: none">• Chapter 3, 4 and 5 edited (add auxiliary pictures, detailed text descriptions)• Chapter 6, 7 and 8 edited (auxiliary pictures added)