

Setup Guide – TEC Controller

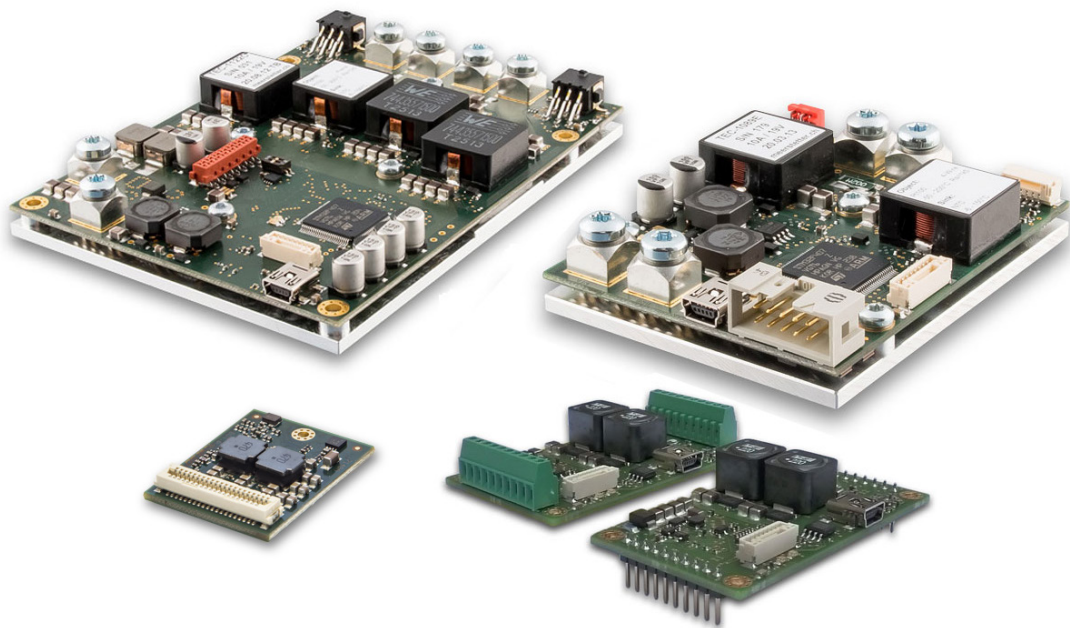

TEC-Family:

TEC-1092
TEC-1091

TEC-1089
TEC-1090

TEC-1122
TEC-1123

Index

- 1 Introduction.....4
- 2 Material & Prerequisites.....5
- 3 Mechanical Setup.....5
- 4 PC Software Installation.....6
 - 4.1 USB Driver Installation.....6
 - 4.2 Microsoft .NET Installation.....6
 - 4.3 TEC Service Software Installation.....6
- 5 Hardware Setup.....7
 - 5.1 Connect the Object Temperature Sensor.....7
 - 5.2 Connect the Peltier Element.....7
 - 5.3 Connect the Power Supply.....7
- 6 Software Setup.....9
 - 6.1 Default Configuration.....9
 - 6.2 Temperature Measurement.....9
 - 6.3 Peltier Element Characteristics.....10
 - 6.4 Temperature Controller.....10
 - 6.5 Auto Tuning.....11
- 7 Further Information.....12

Meerstetter Engineering GmbH

Schulhausgasse 12
CH-3113 Rubigen
Switzerland

Phone: +41 31 712 01 01

Email: contact@meerstetter.ch

Meerstetter Engineering GmbH (ME) reserves the right to make changes without further notice to the product described herein. Information furnished by ME is believed to be accurate and reliable. However typical parameters can vary depending on the application and actual performance may vary over time. All operating parameters must be validated by the customer under actual application conditions.

Document 5182J

Release date: 08 Feb. 2018

1 Introduction

This step by step guide will help you setting up a Meerstetter Engineering TEC Controller for the first time. The goal is to avoid difficulties, save time at first use, and get familiar with the TEC Service Software.

As an example application we set up a thermoelectric cooling system to keep an object at a constant temperature. This means that the TEC Controller will supply a Peltier element, to heat and cool depending on the measured temperature of the object.

The following topics will be treated in this chapter:

1. Software installation
2. Hardware setup
3. Default configuration
4. Temperature measurement
5. Peltier element characteristics
6. Temperature controller
7. PID controller auto tuning

The following symbols are used to categorize the steps of the guide:

- ✕ Actions to be performed by the user
- 🔍 Reactions from the soft- or hardware, as indication that an action was successful
- 📄 Additional background information to the step to be performed

2 Material & Prerequisites

The following components were used for this example:

- TEC-1089-SV-NTC39K controller
- CAB-6154 for TEC-1089
- Peltier element (CUI Inc. CP40236)
- Heatsink
- PC with Microsoft Windows 8
- Cable with mini USB-B connector
- Object temperature sensor (NTC 10K, B value = 3988K)
- Heatsink temperature sensor: none (a fixed temperature value is used)
- Power supply (24V, 6A output)
- Soldering station

This is a general TEC Controller setup guide, so you can follow the steps even if you don't use exactly the same materials and controller for your setup.

3 Mechanical Setup

This is an overview of the cooling system. The TEC Controller is configured and monitored by the Service Software on the PC. The temperature sensor and the Peltier element are connected to the TEC Controller. The Peltier element is placed on the heat sink with the cold side (marked side) facing upwards. The connections are described later, step by step.

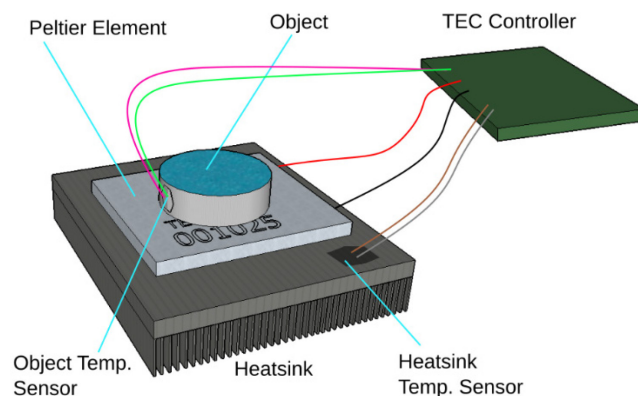
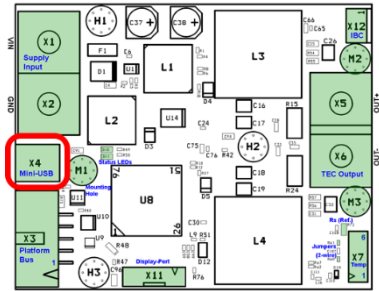

Figure 1. Typical setup of the thermoelectric cooling system, please note that in our example setup we are not using a heatsink temperature sensor.

4 PC Software Installation

4.1 USB Driver Installation

- ✗ Connect the TEC Controller on X4 to your PC using a mini USB-B cable.
- 🔍 Windows will prompt you to install a USB (serial interface) driver - if it's not yet installed.
- ✗ Follow the steps for the installation as shown by Windows.
- 📌 If Windows cannot recognize a new device you can install the driver from [FTDI directly](#).



4.2 Microsoft .NET Installation

- 📌 There are some minimum requirements for the Service Software:
 - Microsoft .NET Framework 4.6.x
 - Microsoft Visual C++ 2015 Redistributable Package
- ✗ [Download and install Microsoft .NET Framework](#), if necessary.
- ✗ [Download and install Microsoft C++ 2015 Redistributable \(important, x86 version, even if you have a 64-bit operating system\)](#), if necessary.
- 📌 For Service Software Versions < 2.70, use Microsoft Visual C++ 2010 Redistributable (x86).

4.3 TEC Service Software Installation

- ✗ [Download the TEC-Family TEC Controllers Software Package \(ZIP\)](#).
- ✗ Right-click on the ZIP-file, click “Properties”, click on “Unblock” on the bottom right.
- ✗ Extract the files to a folder on your PC.
- ✗ Open the Service Software (TEC Service vx.xx.exe).
- ✗ Get familiar with the 10 tabs of the Service Software and their names on top.
- 🔍 The Service Software displays: “No compatible USB device connected” because the TEC Controller is not yet powered by the external power supply.

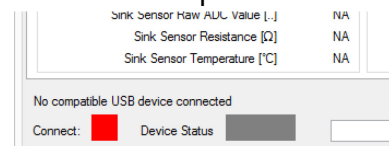

5 Hardware Setup

5.1 Connect the Object Temperature Sensor

- ✗ Consult the pinout in the [CAB-6154 specifications \(PDF\)](#) to learn how to connect the object temperature sensor.
- ✗ Solder the NTC temperature sensor to the pre-assembled cable (grey and yellow wires of CAB-6154).

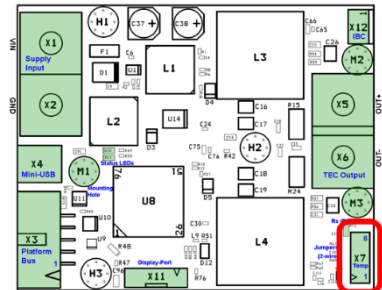
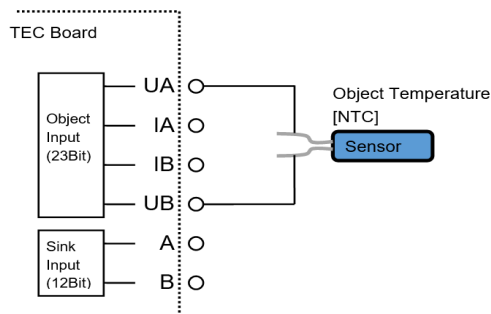

- ✗ Connect the sensor to the TEC Controller's X7 connector.
- ⓘ A sink temperature sensor is not used in our case (pins 1 and 2 of X7 or white and brown wires of CAB-6154).

5.2 Connect the Peltier Element

- ✗ Connect the red cable of the Peltier element to X5 (OUT+).
- ✗ Connect the black cable of the Peltier element to X6 (OUT-).
- ⓘ The cold side of the Peltier element will be the one with the identification marking.

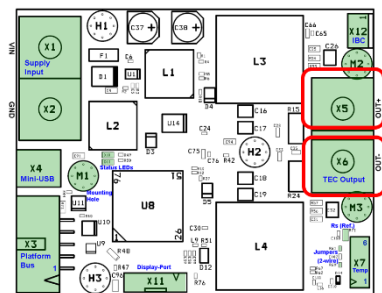

5.3 Connect the Power Supply

- ✗ Set the power supply to 24V.
- ✗ Switch off the power supply.
- ⓘ The power supply must be able to provide enough electric power.

- ✗ Connect the TEC Controller to the power supply at X1 (24V) and X2 (ground).
- ✗ Switch on the power supply.



Q Now that we have everything connected and prepared, our setup looks like this:

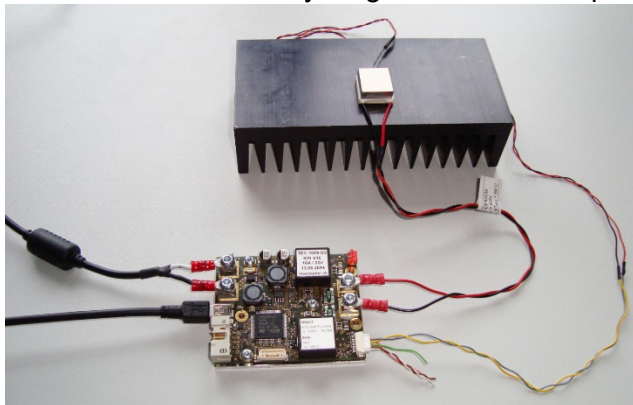

Q The green LED starts flashing continuously on the TEC Controller.

Q The Service Software displays “Connected” and the connect status indicator is green.

Q The “Device Status” is amber and ready.

i Information about your TEC Controller is displayed in the top right corner of the “Monitor” tab.

i If an error occurs, the description is displayed in the “Monitor” tab in the lowest box of the rightmost column.

CH1 Temperature Measurement	
Object Sensor Raw ADC Value [.]	4929203
Object Differential Voltage [V]	NA
Object Sensor Resistance [Ω]	110.205
Object Sensor Temperature [°C]	26.214
Sink Sensor Raw ADC Value [.]	2799
Sink Sensor Resistance [Ω]	9261
Sink Sensor Temperature [°C]	26.760

Connected

Connect: ■ Device Status ■ Ready ■

6 Software Setup

6.1 Default Configuration

- ① We assume that you set up a new TEC Controller with factory defaults.
- ✗ If not, look for the default configuration in the software package you have downloaded from our website (5216x TEC Default Config.ini).
- ✗ Load the default configuration by clicking on “Import Config” in the bottom right corner of the Service Software.
- 🔍 The new values appear in the text fields. They are not yet active on the TEC Controller.
- ✗ Save the changed settings to the TEC Controller by clicking “Write Config” in the bottom right corner of the window.
- ① Generally, you have to set values by typing them into the corresponding fields and by clicking on “Write Config” to save them to the TEC Controller.

6.2 Temperature Measurement

- ① We use a 10K NTC sensor with a B value of 3988K (beta value). In our case, the values for the sensor already correspond to the default settings. If you use another NTC sensor, you will have to set the values given by the datasheet of the sensor.
- ① For Pt100 or Pt1000 sensors the TEC Controller will use internally stored settings.
- ① If a Pt100/1000 sensor is used, 4-wire sensing is used for higher precision. In this case the assembly is done according to the schematic on the right side. Thus, two wires are soldered to each pin of the sensor.
- ✗ If you are not using a NTC 10K B = 3988K sensor, set “CH1 Object NTC Sensor Characteristics” in the tab “Advanced” → “Temperature Conversion” by defining the three resistance values for the corresponding temperature points, given by the datasheet of the sensor.
- 🔍 Check if the temperature measurement in the “Monitor” shows realistic values. The value of “Object Temperature” should equal approx. ambient temperature.

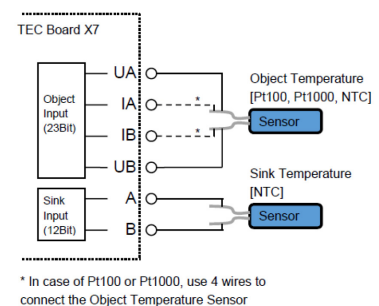

		Actual	New
Upper Point	Temperature [°C]	60	<input type="text"/>
	Resistance [Ω]	2488	<input type="text"/>
Middle Point	Temperature [°C]	25	<input type="text"/>
	Resistance [Ω]	10000	<input type="text"/>
Lower Point	Temperature [°C]	0	<input type="text"/>
	Resistance [Ω]	32650	<input type="text"/>

The screenshot shows the 'Monitor' tab with a 'Temperature Control' sub-tab. It displays the following data:

CH1 Temperature Measurement	
Object Temperature [°C]	26.190
Sink Temperature [°C]	25.000

CH1 Temperature Control	
Target Object Temperature [°C]	25.000
(Ramp) Nominal Object Temperature [°C]	25.000
Thermal Power Model Current [A]	0.00

CH1 Output Stage Monitoring	
Actual Output Current [A]	0.01
Actual Output Voltage [V]	0.01

A red arrow points to the 'Object Temperature [°C]' value of 26.190.

6.3 Peltier Element Characteristics

- ① “CH1 Peltier Characteristics” in the tab “Temperature Control” are values given by the datasheet of the Peltier element. These values cannot be used to limit the output. Limits are set in the tab “Operation”.
- ✘ Search for the two parameters I_{\max} and dT_{\max} in the datasheet of your Peltier element. In our case I_{\max} and dT_{\max} are 4A and 66°C, respectively.
- ✘ In the box “CH1 Peltier Characteristics”, put the two parameters in the corresponding fields.
- ✘ Make sure that the selected “Positive Current is” option is “Cooling”.

6.4 Temperature Controller

6.4.1 Target Object Temperature

- ① Our goal is now to keep an object at a constant temperature. First we set the control parameters, then we have to limit the output of the TEC Controller.
- ✘ In “CH1 Nominal Temperature”, set “Target Object Temp [°C]” to 15.
- ① In “CH1 Modelization for Thermal Power Control” the option “Peltier, Full Control” is selected. That means that the controller can heat and cool the object using the Peltier element.

6.4.2 Operation Limits

- ① Now we need to set the output limits for the operation of the Peltier element.
- ① Limits are set depending on the application. However, generally the voltage limitation should be set approx. 1V over the V_{\max} of the Peltier element and the temperature limitation should be set so that it cannot be reached in normal operation mode.
- ✘ Set “CH1 Output Stage Control Input Selection” to “Temperature Controller”.
- ✘ For this example, we set the “CH1 Output Stage Limits” limitations and error thresholds to these values:
 - “Current Limitation [A]”: 1
 - “Voltage Limitation [V]”: 9.6
 - “Current Error Threshold [A]”: 4.8
 - “Voltage Error Threshold [V]”: 12
- ✘ Set “CH1 Actual Object Temperature Error Limits” in the tab “Object Temperature” to a range that includes your object temperature.
- ① Current Limitation should be 1A at the first startup, but it can be changed later. Generally, the current limitation should be equal to 0.7 times I_{\max} of the Peltier Element.
- ① Error thresholds should be set approx. 20% above the corresponding limits. An error is generated and the TEC Controller is stopped if a value reaches its threshold.

6.4.3 Functionality Check

- ✗ In the tab “Operation”, set “CH1 Output Stage Enable” to “Static ON”.
- 🔍 Observe the temperature in the “Chart” tab.
- 🔍 The temperature will converge to 15°C.
- 🔍 In the status bar at the bottom, the CH1 object temperature indicator is amber if the target temperature has not yet been reached.
- 🔍 If the measured “Object Temperature” equals the target temperature the indicator is green.
- 🔍 There can be a small difference between the desired target temperature and the measured object temperature.
- 🔍 If the temperature is changing in the wrong direction, the Peltier element is connected the wrong way. Switch the wires at X5 and X6 and test your setup again.
- 🔍 See step 5.2 for more information about how to connect the Peltier element.



6.5 Auto Tuning

- ① To be able to precisely control the object temperature we have to optimize the control system of the TEC Controller. This can be done automatically by using the integrated PID tuning function in the “Auto Tuning” tab.
- ✗ In the tab “Operation”, make sure that “CH1 Output Stage Enable” is set to “Static ON”.
- ✗ Check in the “Chart” tab if the chosen target temperature is approx. reached and if it is stable.
- ✗ Click on the “Start” button in the “Auto Tuning” tab.
- 🔍 The Auto Tuning function now tries to optimize the system and seeks optimum PID controller values.

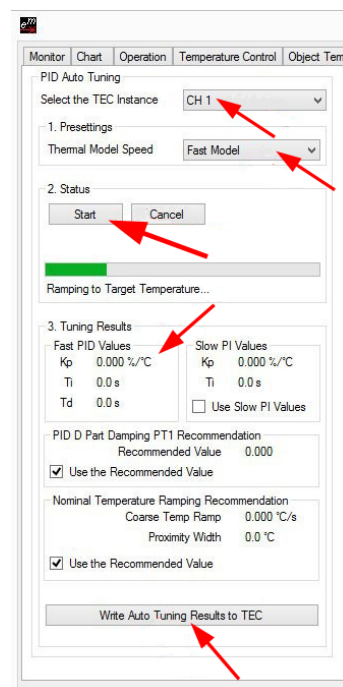

- 🔍 You can observe the progress in the “Chart” tab:
 - 16:33:00 Auto Tuning started
 - 16:33:50 Auto Tuning finished
 - 16:34:30 New PID values applied
- ✗ If the tuning was successful, the found values can be saved by clicking on “Write Auto Tuning Results to TEC” back in the “Auto Tuning” tab.
- ✗ If it was not successful, try the option “Slow Model” as “Thermal Model Speed”.
- ① The system will use the found PID parameters from now on to control the object temperature if the tuning was successful.

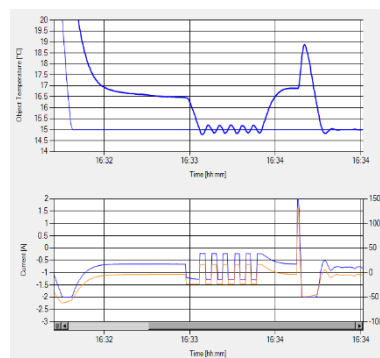

7 Further Information

Congratulations! Your TEC Controller should now be working and you should be able to set up a simple application with your TEC Controller.

Please refer to the [TEC-Family User Manual](#) for detailed information about the Service Software and the TEC Controllers, and to find additional troubleshooting help.

[The TEC / Peltier Element Design Guide on our website](#) provides more information about how to design a thermoelectric application including calculations, choosing Peltier elements, temperature sensors, heat sinks and power supplies.