

## Evaluation Board for TEC Controller

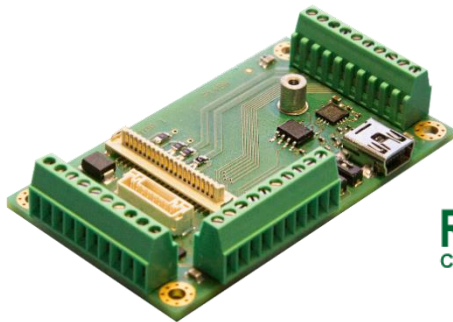

**RoHS**  
COMPLIANT

## Features

### Input Characteristics:

- DC Input Voltage: 5 to 12 V

### Main Features:

- USB connector to interface the TEC-1092
- Interface for TEC-1092
- ESD protection
- Screw connectors

### Special Requirements / More Information:

- Please contact us for additional information or customization.

### General Description:

The EVL-1093 is an evaluation board for the TEC-1092 TEC Controller and provides easy connectivity for it.

The TEC-1092 is not included with the EVL-1093.

It has exactly the same size and pinout as the TEC-1091. (Except the additional connector X5)

Please refer to the datasheet of the TEC-1092 (document 5208) for more information.

### Absolute Maximum Ratings

Supply voltage (DC)	20 V
---------------------	------

### Operating Ratings

Temperature	-40 – 90°C
Humidity	5 – 95%, non-condensing

### Electrical Characteristics

Unless otherwise noted:  $T_A = 25\text{ °C}$ ,  $V_{IN} = 12\text{ V}$

Symbol	Parameter	Test Conditions	Min	Typ	Max	Units
<b>DC Power Supply Input:</b>						
$V_{IN}$	Supply voltage		4.9		12	V
<b>USB:</b>						
$U_{PP}$	Electrical isolation				1	kV

### RS232 TTL and General Purpose Digital I/O Characteristics (GPIO1 ... GPIO8, RX, TX)

Unless otherwise noted:  $T_A = 25\text{ °C}$ ,  $U_{IN} = 12\text{ V}$

Symbol	Parameter	Comments	Min	Typ	Max	Units
<b>ESD Protection:</b> (Between TEC-1092 and Connector)						
$U_{PP}$	ESD discharge	IEC61000-4-2			100	kV
$R_A$	Series resistance		170	200	230	$\Omega$

**Pin Configuration and Mechanical Data**

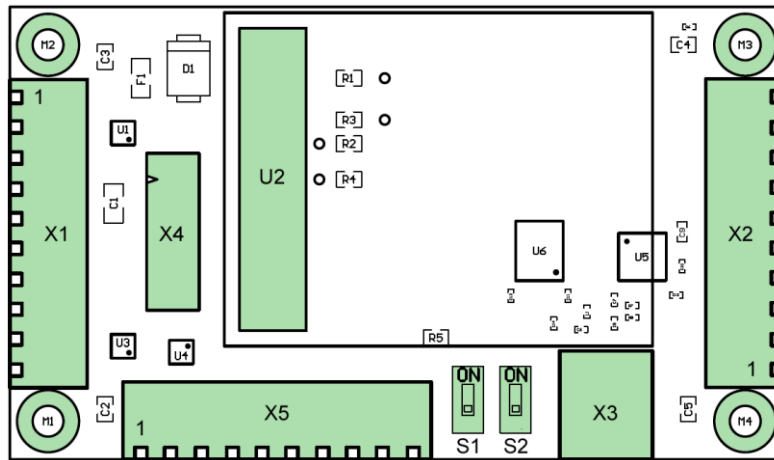

Top view

**Pin Description:**

X1	1	Power VIN
	2	Power GND
	3	GPIO1
	4	GPIO2
	5	GPIO3
	6	GPIO4
	7	RS232 TTL RX
	8	RS232 TTL TX
	9	RS485 A2 (D+)
	10	RS485 B2 (D-)
X2	1	Object temperature sensor IA
	2	Object temperature sensor IB
	3	Object temperature sensor UA
	4	Object temperature sensor UB
	5	Shield
	6	Sink temperature sensor A
	7	Sink temperature sensor B
	8	GND
	9	Out- (Peltier element minus)
	10	Out+ (Peltier element plus)
X5	1	GPIO5
	2	GPIO6
	3	GPIO7
	4	GPIO8
	5	NC
	6	NC
	7	NC
	8	NC
	9	3.3 V
	10	5 V
X3	USB mini B	
X4	Status Display Kit DPY-1113 connector	
U2	TEC-1092 connector	

U2	TEC-1092 connector
S1	On: 120 Ω RS485 termination enabled
S2	On: USB connectivity enabled Off: RS232 TTL connectivity enabled

**Dimensions:**

65 mm x 38 mm x 14 mm

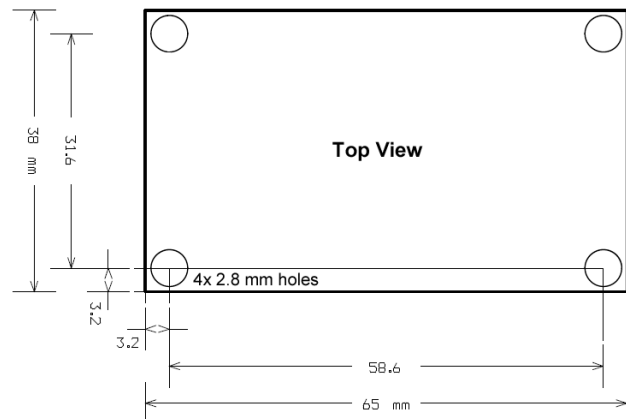

## Operation-Modes / Theory of Operation

The EVL-1093 allows the evaluation and simple connection of a TEC-1092 to a host system using USB. Further, a DPY-1113 TEC Status Display Kit can be connected.



**Schematic**

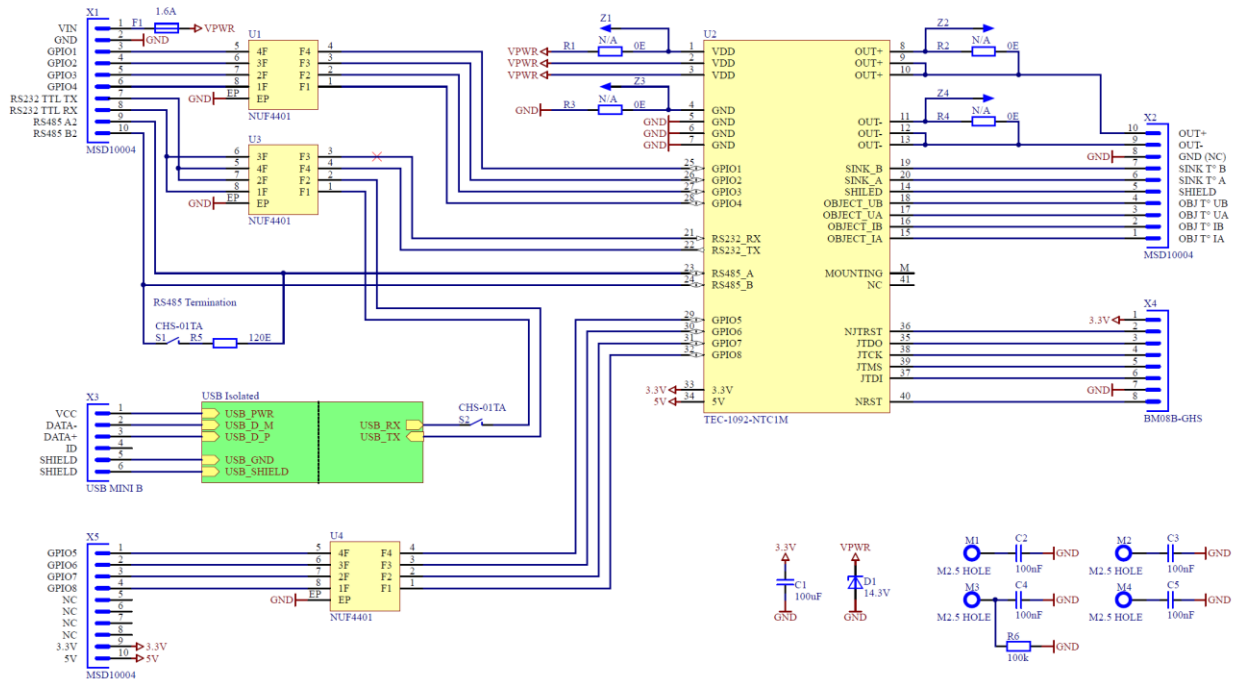

Confidential	<b>EVL-1093</b>		4147B
	TOP.SchDoc		
	Meerstetter Engineering GmbH Schulhaugasse 12 CH-3113 Rübigen Phone: +41 31 712 01 01	Revision: Unknown revision Layout: 7149B Designed: 16.09.16 ML Modified: 09.10.17 ML	

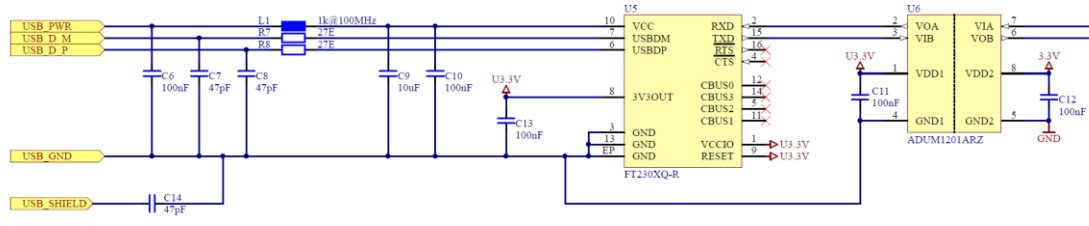

Confidential	<b>EVL-1093</b>		4147B
	USB.SchDoc		
	Meerstetter Engineering GmbH Schulhaugasse 12 CH-3113 Rübigen Phone: +41 31 712 01 01	Revision: Unknown revision Layout: 7149B Designed: 16.09.16 ML Modified: 09.10.17 ML	

Please contact Meerstetter Engineering if you need the whole Altium Project inclusive layout.

## Parts List

Quantity	Referenze	Component	Value	Manufacturer	Manufacturer Part No.
1	PCB	PCB 7149B	EVL-1093	MEERSTETTER ENGINEERING	ME7149B
3	C7, C8, C14	CAPACITOR CERAMIC	47pF / 50V	TDK	C1005C0G1H470J
5	C6, C10, C11, C12, C13	CAPACITOR CERAMIC	100nF / 25V	TDK	C1005X7R1E104K050BB
4	C2, C3, C4, C5	CAPACITOR CERAMIC X7R	100nF / 50VDC	AVX	08055C104KAT2A
1	C9	CAPACITOR CERAMIC	10uF / 10V	MURATA	GRM188R61A106KE69 D
1	C1	CAPACITOR CERAMIC X5R	100uF / 10V	TDK	C3216X5R1A107M160A C
4	R1, R2, R3, R4	RESISTOR- 0.1W-1% SMD	0E	MULTICOMP	MC 0.1W 0805 0R
2	R7, R8	RESISTOR- 63mW-1% SMD	27E	VISHAY DRALORIC	CRCW040227R0FKED
1	R5	RESISTOR ANTI-PULSE SMD	120E / 0.25W	PANASONIC	ERJT06J121V
1	R6	RESISTOR- 125mW-1% SMD	100k	VISHAY DRALORIC	CRCW0402100KFKEAH P
1	L1	FERRITE BEAD	1k@100MHz	TAIYO YUDEN	BK1005HS102-T
1	F1	FUSE SMD FAST	1.6A / 63VDC	SCHURTER INC	3413.0218.22
1	D1	DIODE TRANSIL UNIDIR SMD	VBR MIN = 14.3V	ST MICROELECTRONICS	SM6T15A
2	S1, S2	SWITCH DIP 1POS SMD	CHS-01TA	COPAL ELECTRONICS	CHS-01TA
3	U1, U3, U4	FILTER EMI / ESD	NUF4401	ON SEMICONDUCTOR	NUF4401MNT1G

Quantity	Referenze	Component	Value	Manufacturer	Manufacturer Part No.
1	U6	DIGITAL ISOLATOR 2CH 1MB	ADUM1201ARZ	ANALOG DEVICE	ADUM1201ARZ
1	U5	USB TO SERIAL CONVERTER	FT230XQ-R	FTDI CHIPS	FT230XQ-R
1	X3	CONNECTOR USB SMD	USB TYP B MINI HORIZONTAL	WÜRTH ELECTRONICS	65100516121
1	X4	CONNECTOR 8POL SMD	BM08B-GHS	JST	BM08B-GHS-TBT
3	X1, X2, X5	SCHRAUBKLE MME 10POL	MSD10004	SAURO	MSD10004
1	U2	CONNECTOR 41POL SMD	91911-31341LF	AMPHENOL FCI	91911-31341LF
1	U2	EINLÖT DISTANZBOLZEN	M2X5	WÜRTH ELEKTRONIK	9774050243

### EVL-1093 Ordering Information, Hardware Configuration

Example Configuration: **EVL-1093-SCREW**

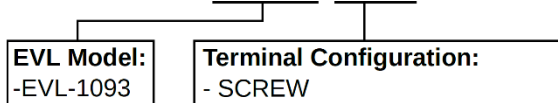

#### Display Unit:

It is possible to connect an OLED 2x16 character display directly to the X4 connector. Please visit the DPY - 1113 product web page for further information.

#### Customization:

Many hardware and software features of the EVL-1093 are customizable upon request. Please contact Meerstetter Engineering with your enquiry.