

TEC-1161-4A / TEC-1161-10A

Hardware Version v1.30

The **TEC-1161-4A / -10A** is a high-precision dual-channel thermoelectric controller designed for driving and monitoring Peltier elements with exceptional accuracy & stability. Featuring fully digital control, intelligent PID auto-tuning, and comprehensive communication interfaces, it offers a complete solution for demanding temperature-controlled applications. Optional Advanced Features such as Cascade Temperature Control, Channel Splitting and Temperature Estimation are available through Software.

HIGHLIGHTS

- **Output per Channel:** var. up to $\pm 4\text{ A}$ / $\pm 10\text{ A}$, $\pm 21\text{ V}$
- **Input Voltage:** 5 – 24 VDC
- Typical cooling capacity: $2 \times 42\text{ W}$ / $2 \times 105\text{ W}$ (@COP=0.5)
- Temperature precision/stability: $\leq 0.01\text{ }^\circ\text{C}$
- Control Frequency: 1 Hz, 10 Hz, 90 Hz
- Dimensions: $77 \times 48 \times 19\text{-}22.2\text{ mm}$
- Digital PID control with auto-tuning
- Smooth temperature ramping and thermal stability indicator
- Stand-alone or remote-controlled operation via USB (isolated), RS485, RS232 TTL (on request) or CANopen CiA 301 (FW \geq v5.10)
- GUI software for configuration and data logging
- Supports Pt100, Pt1000, NTC or Voltage sensors (4-wire precision input). The analog measurement circuit is factory calibrated
- GPIO features for monitoring and control (Enable, Error Indication, Fan Control, etc.)
- Two independent channels for individual or common loads
- Supports Peltier elements and resistive heaters
- Available as screw-terminal or PCB-mount OEM module

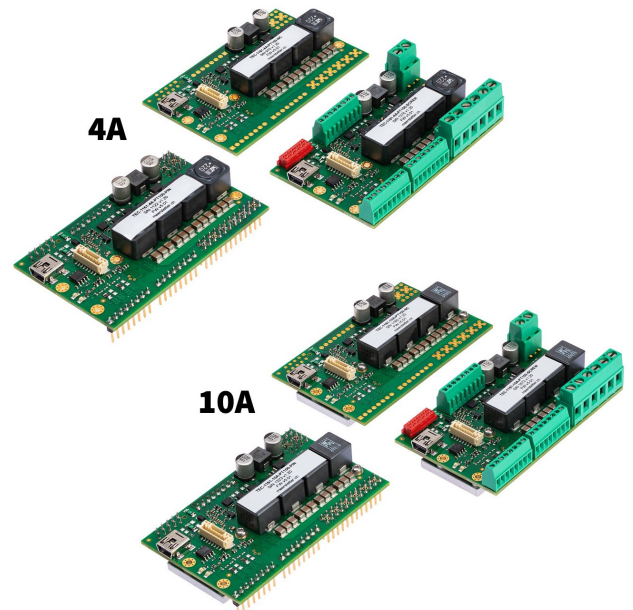

Trial Device & Technical Support

Trial devices and technical support are available for evaluation projects. Please contact support@meerstetter.ch or visit our [support center](#).

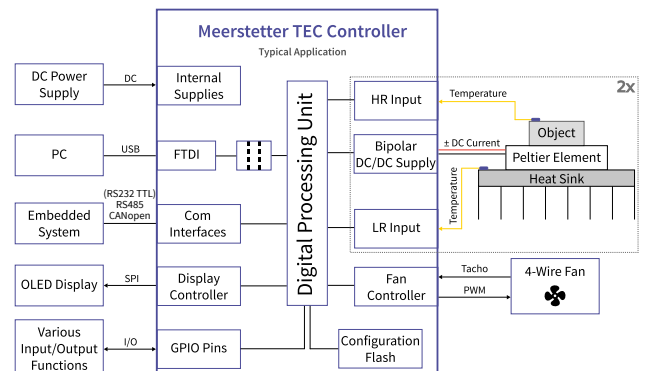

RELATED PRODUCTS

Model	Channels	Output per Channel	Description
TEC-1167	2	$\pm 25\text{ A}$ / $\pm 56\text{ V}$	higher power
TEC-1166	2	$\pm 5\text{ A}$ / $\pm 56\text{ V}$	newer generation
TEC-1091	1	$\pm 4\text{ A}$ / $\pm 21\text{ V}$	single-channel alternative, lower power
TEC-1163	1	$\pm 25\text{ A}$ / $\pm 56\text{ V}$	single-channel alternative, higher power

See the [full product overview](#) in the Meerstetter Engineering's Product Compatibility section.

TABLE OF CONTENTS

1	Specifications	3
1.1	Absolute Maximum Ratings.....	3
1.2	Operating Characteristics.....	3
1.3	Efficiency	4
1.4	Electrical Characteristics 4A Model	5
1.5	Electrical Characteristics 10A Model	6
1.6	Output Safety Characteristics	6
2	Temperature Characteristics	7
2.1	High Resolution Temperature Measurement Characteristics (Pt100 and Pt1000 Probes).....	7
2.2	High Resolution Temperature Measurement Characteristics (NTC Probes)	7
2.3	High Resolution Temperature Measurement Characteristics (Voltage Measurement VIN1/VIN2)	7
2.4	Low Resolution Temperature Measurement Characteristics (NTC only)	7
3	Functional Description	8
3.1	Typical Application	8
3.2	Operation Modes and Communication Options	9
3.3	Hardware Configuration	9
4	Interface and Connectors	10
4.1	General Purpose Digital I/O Characteristics (GPIO1 ... GPIO10).....	10
4.2	Auxiliary Connector X5 Power Supply Output Characteristics	10
4.3	Pin Configuration Screw Connectors TOP View	11
4.4	Matching Receptacles for the PIN Configuration.....	11
4.5	Screw Connector Specifications X1 and X2	11
4.6	Screw Connector Specifications X3, X4 and X8.....	12
4.7	Temperature Sensor Connection X4 and X8	12
4.8	Pin Configuration Pinheader Connectors TOP View	12
4.9	Pin Configuration Auxiliary IO Connector X5	13
4.10	Mini USB Connector X6.....	13
4.11	Display Connector X9.....	13
4.12	Temperature Sensor Connection X4 and X8	13
5	Mechanical Data	14
5.1	Dimensions	14
6	Ordering and Configuration	15
6.1	TEC-1161 Ordering Information & Configuration	15
6.2	Ordering Confirmation Example	15
7	All Meerstetter Engineering Products	16
7.1	Meerstetter Engineering's Product Compatibility	16
8	Change History	17

1 SPECIFICATIONS

1.1 Absolute Maximum Ratings¹

		Min	Max	Unit
Voltage	$U_{IN, DC}$		25.5	V
	$U_{IN, GPIO}$	-0.5	5.5	V

¹ Operation at or beyond the absolute maximum ratings may result in permanent device damage. These limits are stress ratings only and functional operation of the device at these conditions is not guaranteed. Prolonged exposure to absolute maximum conditions can adversely affect long-term reliability and should be avoided during normal operation.

1.2 Operating Characteristics

		Min	Max	Unit
Temperature	T_{OP}	-40	90	°C
Humidity	$RH_{OP, non-condensing}$	5	95	%

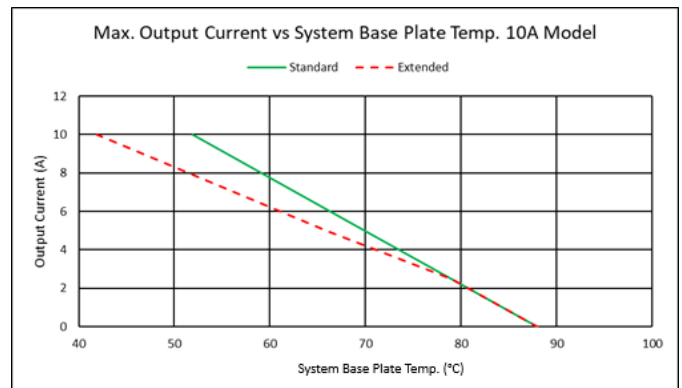
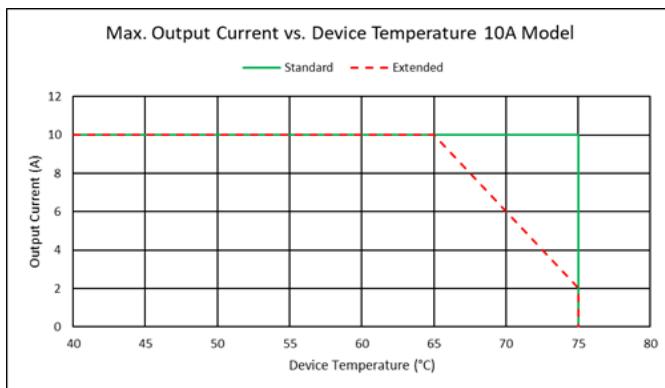
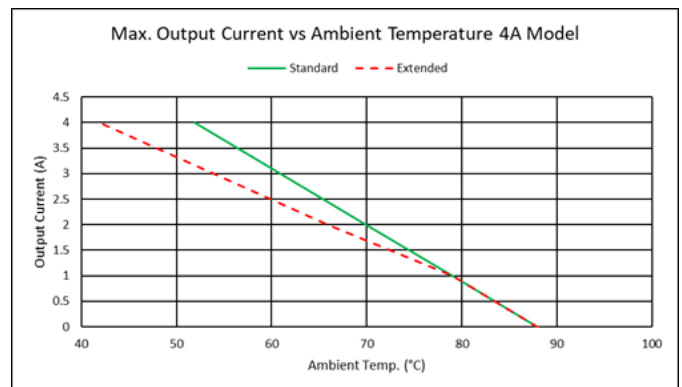
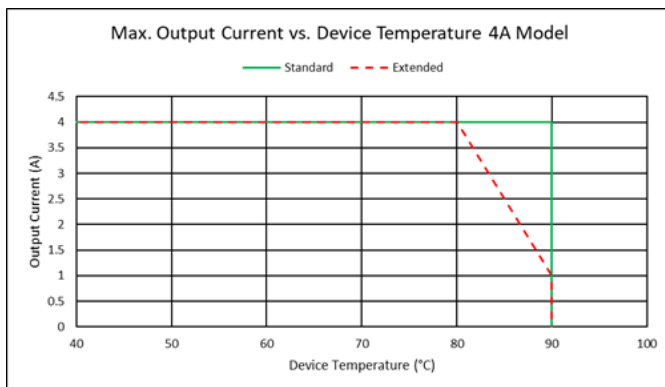

Standard or Extended Device Temperature Mode can be set as software setting.

The right Diagram shows the situation with an external 3.3 Ω resistor (4 A Model) or a 1.65 Ω resistor (10 A Model). No forced air flow was present.

1.3 Efficiency

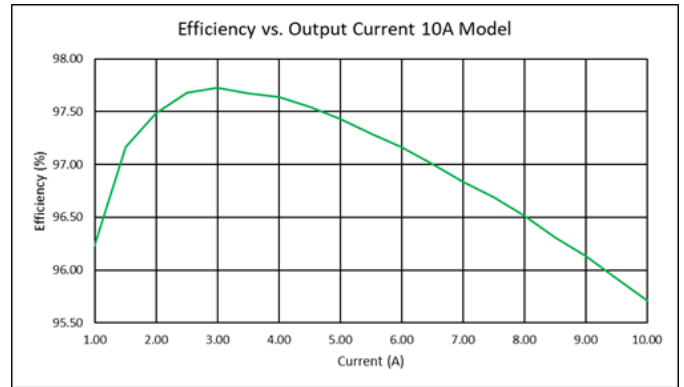
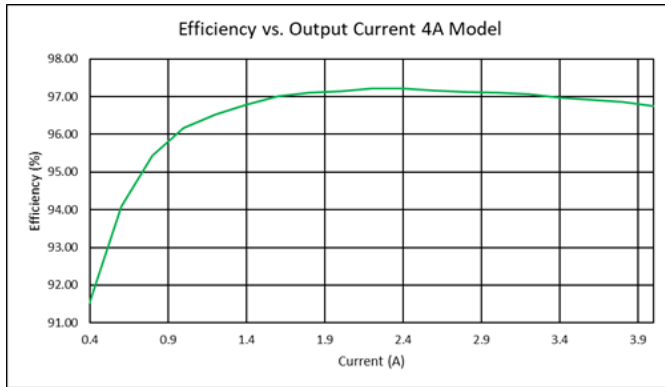

The Efficiency measurements were done at 21 V output voltage and a device temperature of 60°C. The ambient temperature was 23°C, no forced air flow was present.

1.4 Electrical Characteristics 4A Model

Unless otherwise noted: $T_A = 25\text{ °C}$, $U_{IN} = 24\text{ V}$, $R_{load} = 3.3\ \Omega$

Symbol	Parameter	Test Conditions / Hints	Min	Typ	Max	Units
DC Power Supply Input:						
U_{IN}	Supply voltage	Measured directly on power input terminals	4.9		24	V
U_{IN} Ripple	Ripple tolerance	U_{IN} never below U_{IN} min or above U_{IN} max			300	mV _{PP}
I_{IN}	Max input current	Hint: Software limitation			10	A
Output (per Channel):						
I_{OUT}	Bipolar current				±4	A
U_{OUT}	Bipolar voltage	U_{OUT} is maximum $\sim 0.9 * U_{IN}$			±21	V
I_{OUT}	Unipolar current ¹				4	A
U_{OUT}	Unipolar voltage ¹	U_{OUT} is maximum $\sim 0.9 * U_{IN}$			21	V
U_{OUT} Ripple	Voltage ripple	@ 4 A			100	mV _{PP}
System Characteristics:						
$\eta_{50\%}$	Power efficiency	@ 50 % load (10.5 V, 4 A)		94		%
$\eta_{100\%}$	Power efficiency	@ 100 % load (21 V, 4 A)		96		%
Output Monitoring: (I_{OUT} Resolution is 1.46 mA; U_{OUT} Resolution is 6.1 mV)						
I_{OUT} Read	Precision	@ 3.8 A		1	5	%
U_{OUT} Read	Precision	@ 15.0 V		1	3	%

¹ In unipolar mode, the total output power is doubled in comparison to the bipolar mode, but the controller input current is limited to I_{IN} , which limits the total available output power. The controller limits the output current for each channel dynamically if the max input current limit is reached.

1.5 Electrical Characteristics 10A Model

Unless otherwise noted: $T_A = 25\text{ °C}$, $U_{IN} = 24\text{ V}$, $R_{load} = 1.65\ \Omega$

Symbol	Parameter	Test Conditions / Hints	Min	Typ	Max	Units
DC Power Supply Input:						
U_{IN}	Supply voltage	Measured directly on power input terminals	4.9		24	V
U_{IN} Ripple	Ripple tolerance	U_{IN} never below U_{IN} min or above U_{IN} max			300	mV _{PP}
I_{IN}	Max input current	Hint: Software limitation			22	A
Output (per Channel):						
I_{OUT}	Bipolar current				±10	A
U_{OUT}	Bipolar voltage	U_{OUT} is maximum $\sim 0.9 * U_{IN}$			±21	V
I_{OUT}	Unipolar current ¹				10	A
U_{OUT}	Unipolar voltage ¹	U_{OUT} is maximum $\sim 0.9 * U_{IN}$			21	V
U_{OUT} Ripple	Voltage ripple	@ 10 A			350	mV _{PP}
System Characteristics:						
$\eta_{50\%}$	Power efficiency	@ 50 % load (10.5 V, 10 A)		93		%
$\eta_{100\%}$	Power efficiency	@ 100 % load (21 V, 10 A)		95		%
Output Monitoring: (I_{OUT} Resolution is 3.5 mA; U_{OUT} Resolution is 6.1 mV)						
I_{OUT} Read	Precision	@ 9.8 A		1	5	%
U_{OUT} Read	Precision	@ 15.0 V		1	3	%

¹ In unipolar mode, the total output power is doubled in comparison to the bipolar mode, but the controller input current is limited to I_{IN} , which limits the total available output power. The controller limits the output current for each channel dynamically if the max input current limit is reached.

1.6 Output Safety Characteristics

Unless otherwise noted: $T_A = 25\text{ °C}$, $U_{IN} = 12\text{ V}$

Symbol	Parameter	Test Conditions / Hints	Min	Typ	Max	Unit
Output Stage Protection Delays:						
t_{OFF}	Short circuit	Full load condition		10	30	μs
t_{OFF}	Power system limits	Current and voltage limits			200	μs
Output Stage Current Supervision: (If the OUT+ and OUT- currents differ too much, an error is generated)						
I_{OUT_DIFF}	Error threshold			120		mA

2 TEMPERATURE CHARACTERISTICS

2.1 High Resolution Temperature Measurement Characteristics (Pt100 and Pt1000 Probes)

Measurement configuration = 23 bit / 4-wire / unshielded cable < 50 mm

Symbol	Parameter	Test Conditions / Hints	Min	Typ	Max	Unit
$T_{HR, RANGE}$	Range	Range is extendable upon request Extended measurement range is -193°C ... +787°C	-220		200	°C
$T_{HR, PREC}$	Precision	(EN 60751 / IEC 751)		0.005		°C
$T_{HR, COEFF}$	Temp. Coefficient	Relative to device temperature			1.6 m	°C/K
$T_{HR, NOISE}$	Value Noise	Reference measurement fluctuations while output stage operating @70% load		0.005		°C
$T_{HR, REP}$	Repeatability	Repeated measurements of reference resistors after up to 3 days		0.008		°C

2.2 High Resolution Temperature Measurement Characteristics (NTC Probes)

NTC thermistor resistive input characteristics translate into temperature ranges valid for only one type of NTC probe. Below example is given in the case of an NTC B_{25/100} 3988K R₂₅ 10k temperature sensor.

Symbol	Parameter	Test Conditions / Hints	Min	Typ	Max	Unit
$R_{HR, RANGE}^1$	ADC Auto Gain PGA = 1 or 8 or 32		73 ≈ 194.3		1M ≈ -55.5	Ω °C

¹ $R_{HR, RANGE}$ is the resistance range of the NTC sensor

2.3 High Resolution Temperature Measurement Characteristics (Voltage Measurement VIN1/VIN2)

Sensors with linear Voltage/Temperature output

Symbol	Parameter	Test Conditions / Hints	Min	Typ	Max	Unit
$U_{SENS, DIFF}$	Range	Differential input voltage Temperature range depends on sensor used	-2.039		2.039	V
$U_{HRUX, ABS}$	Range	Absolute input voltage	-0.1		5.1	V

2.4 Low Resolution Temperature Measurement Characteristics (NTC only)

$T_A = 25^\circ\text{C}$, measurement configuration = 12 bit / 2-wire / unshielded cable < 50 mm, °T probe = NTC B_{25/100} 3988K R₂₅ 10k

Symbol	Parameter	Test Conditions / Hints	Min	Typ	Max	Unit
$R_{LR, RANGE}$	Range		50 ≈ 214.0		49781 ≈ -8.1	Ω °C

3 FUNCTIONAL DESCRIPTION

3.1 Typical Application

Following image gives an overview of a typical thermoelectric cooling (TEC) application using a Meerstetter Engineering TEC Controller to drive a [thermoelectric heat pump](#), often also referred to as Peltier element.

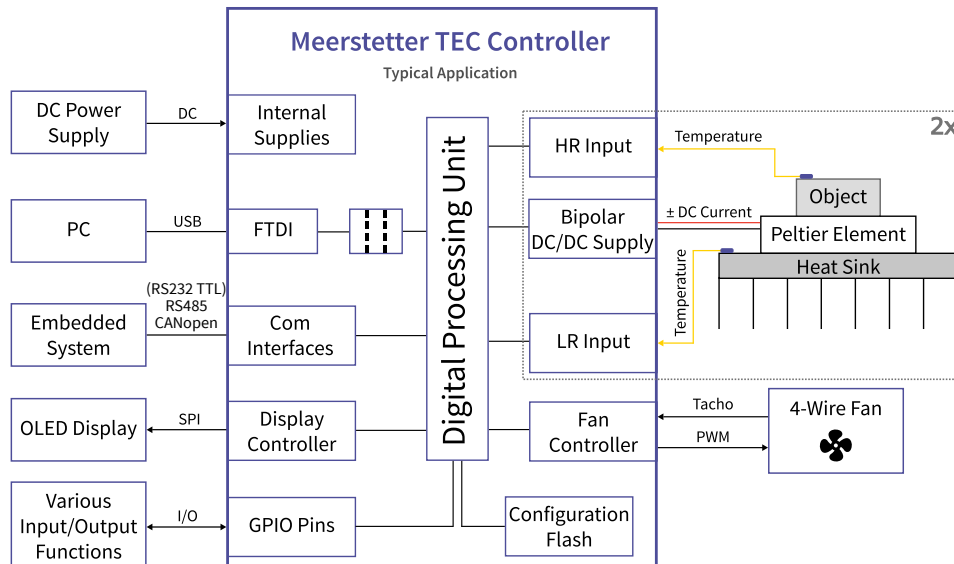

A bipolar DC/DC converter supplies power the Peltier element in unipolar directions. This enables both heating and cooling of the object. A 23-bit high-resolution (HR) measurement input continuously measures the object temperature. Using the acquired temperature, the object temperature is controlled and held stable (deviation is typically 0.01 °C or less) by adjusting the heat pumping capacity.

Waste heat from the object is pumped to a heat sink and further radiated into the environment. A low-resolution (LR) input monitors the temperature of the heat sink to further optimize the control algorithm (not required but recommended). Optional fans enable controlling the sink temperature through forced air removal. The TEC Controller features two separate 4-Wire fan interfaces with integrated fan control.

Once configured, the device operates standalone by storing its configuration parameters in internal non-volatile flash storage. The configuration can be changed by using our [configuration software](#) or [MeComAPI](#) through the isolated USB port or RS-interfaces. Additionally, CANopen CiA 301 support provides options for advanced system integration. Please ensure that the device supports your required communication interface and refer to the [Remote Control Guide](#) for more detailed information.

For easy on-site status information, an OLED display can be connected to show any parameter by freely setting it up through software.

The controller supports various GPIO functionalities for monitoring and controlling of the device. Features include Driver Enable, Error Indication, Fan Control & Pump Enable, Temperature Stable Indication, Temperature Increment/Decrement and more. Most functions can be freely assigned to any GPIO.

i For more information on the operation of the device and the Peltier elements, as well as how to dimension them, please refer to the [compendium](#) on our website.

3.2 Operation Modes and Communication Options

The TEC-1161 is an OEM precision TEC Controller that is available with Screw Terminals or as a PCB mountable device. Its basic operation status is visually indicated by on-board green and red LEDs and their blinking pattern.

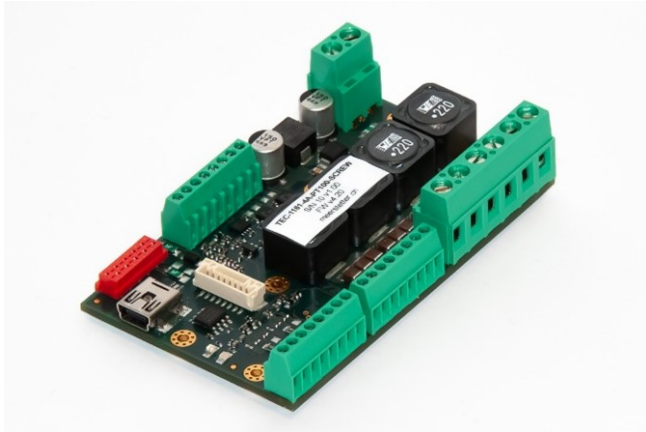

Screw terminal equipped Version

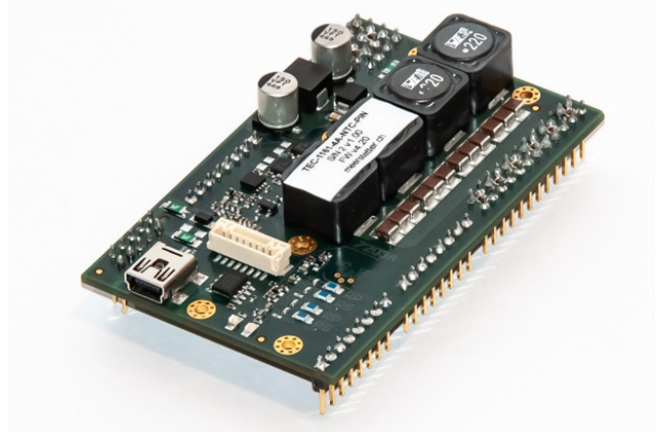

PIN PCB mountable Version

Status information can be polled at any time by industry standard RS485 connection or by USB. The TEC-1161 can also operate in a remotely controlled manner, with parameters adjusted on the fly. Scripting capability by sequential lookup table read-out is supported.

Configured as a DC power-supply, the TEC-1161 can handle current and voltage settings. In the remote-control case, temperature data may be passed on to be processed by the host.

Configurable parameters further include sensor linearization (Pt100 / Pt1000) and Steinhart-Hart modeling (NTC), temperature acquisition hardware calibration, Peltier element modeling, PID controller auto tuning, nominal temperature ramping, current, voltage and temperature limits, error thresholds, etc. Please refer to the TEC Controller User Manual (Document 5216) for further information.

3.3 Hardware Configuration

High Resolution Sensor Type:

NTC: By default, we mount an NTC1M. If you require an older version (NTC18K, NTC39K or NTC56K), please write which one you need in the comment section of your order or contact us: contact@meerstetter.ch.

Terminal Configuration:

The Device is available with different types of connectors for X1 – X4 and X8:

- **NC** (no connector)
- **SCREW** (5.12 mm (X1,X2) and 2.56 mm (X3, X4, X8) Screw Terminals)
- **PIN** (2.54 mm Pin Header; X1 and X2 have multiple pins per position)

Thermocouple:

To use our TEC Controllers with thermocouples type K, you need a TCI-1181 in addition to the TEC Controller with a VIN1 or VIN2 High Resolution Sensor Type configuration.

Display Unit:

It is possible to connect a small or big OLED 2x16 / 4x20 character display directly to the X9 connector of the device. Please visit the [DPY-111x](#) product pages on our website for further information.

Customization:

Many hardware and software features of the TEC-1161 are customizable upon request. Please contact Meerstetter Engineering with your enquiry.

4 INTERFACE AND CONNECTORS

4.1 General Purpose Digital I/O Characteristics (GPIO1 ... GPIO10)

Unless otherwise noted: $T_A = 25\text{ °C}$

Symbol	Parameter	Test Conditions / Hints	Min	Typ	Max	Units
Input Characteristics:						
U_{IH}	Logic high input threshold		2.38			V
U_{IL}	Logic low input threshold				0.93	V
U_{IMAX}	Maximum input voltage	General Purpose Inputs are 5V-tolerant	-0.5		5.5	V
Output Characteristics: (Microprocessor)						
U_{OH}	Logic high output voltage	Output current 8 mA	2.8	3.3	3.4	V
U_{OL}	Logic low output voltage	Input current 8 mA			0.4	V
Z_{OUT}	Output Impedance		110	120	150	Ω
I_{OUT}	Output Sink or Source Current			± 8	± 20	mA
ESD Protection: (Between Processor and Connector)						
U_{PP}	ESD discharge	IEC61000-4-2		18		kV
R_A	Series resistance		85	100	115	Ω

4.2 Auxiliary Connector X5 Power Supply Output Characteristics

Unless otherwise noted: $T_A = 25\text{ °C}$

Symbol	Parameter	Test Conditions / Hints	Min	Typ	Max	Units
Input Characteristics:						
U_{OUT}	Output Voltage	Output Current 50 mA	4.4	4.5	5.0	V
I_{OUT}	Output Current		0	150	200	mA
U_{IMAX}	Maximum input voltage		-0.5		5.5	V

4.3 Pin Configuration Screw Connectors TOP View

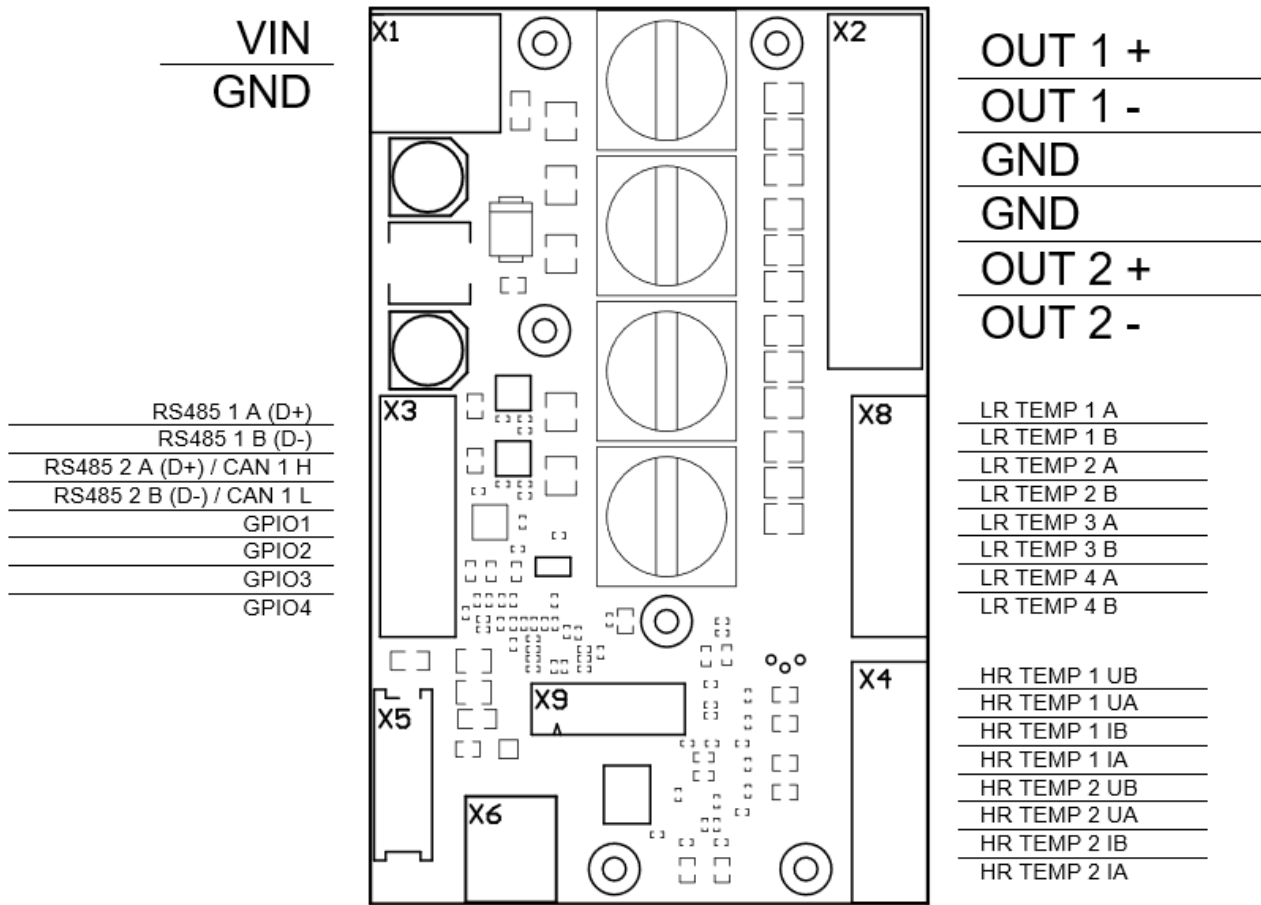

4.4 Matching Receptacles for the PIN Configuration

The following receptacles can be used for the TEC-1161 in the -PIN Configuration.
 Manufacturer: MILL-MAX MANUFACTURING Part Number: 801-43-050-10-001000
 The receptacles need to be broken up into the appropriate length.

4.5 Screw Connector Specifications X1 and X2

Symbol	Parameter	Test Conditions / Hints	Min	Typ	Max	Units
A _{WIRE}	Wire Size	Mechanical Limit; current carrying capacity not considered	0.05		2.5	mm ²
τ _{SCREW}	Tightening Torque			0.5	0.6	Nm
L _{STRIP}	Stripping Length			6.5		mm

4.6 Screw Connector Specifications X3, X4 and X8

Symbol	Parameter	Test Conditions / Hints	Min	Typ	Max	Units
A _{WIRE}	Wire Size	Mechanical Limit; current carrying capacity not considered	0.05		0.5	mm ²
τ _{SCREW}	Tightening Torque			0.1		Nm
L _{STRIP}	Stripping Length			5		mm

4.7 Temperature Sensor Connection X4 and X8

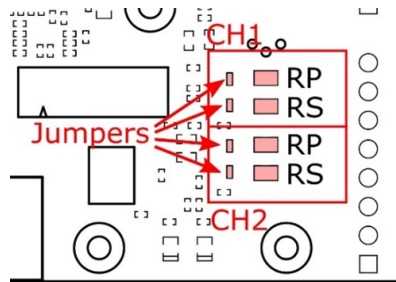

The jumpers are used for the 2/4 Wire configuration. For the values of RS and RP please refer to the TEC-Controller User Manual.

4.8 Pin Configuration Pinheader Connectors TOP View

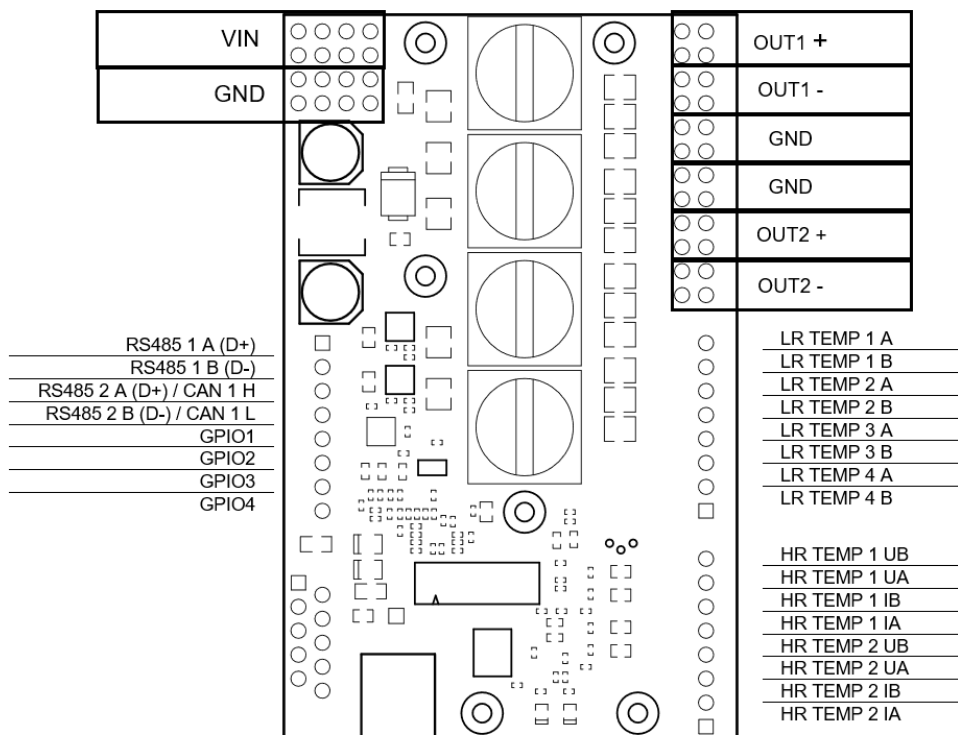

4.9 Pin Configuration Auxiliary IO Connector X5

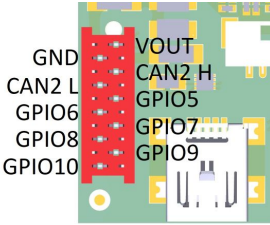
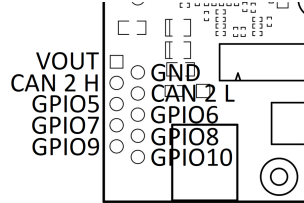
Mini-Module Plug	Pin-Header
 <p>Plug used: Würth MINI MODULE Part Number: 690367181072</p> <p>Matching Connector: Würth Part Number: 690157001072</p> <p>CANopen is only available on CAN1</p>	

4.10 Mini USB Connector X6

The Mini USB Connector X6 can be used to communicate with the TEC Controller using the MeCom communications protocol or the software. It is electrically isolated.

4.11 Display Connector X9

The Connector X9 can be used to connect one of the OLED Displays available from Meerstetter (DPY-1113, DPY-1114 or DPY-1115).

4.12 Temperature Sensor Connection X4 and X8

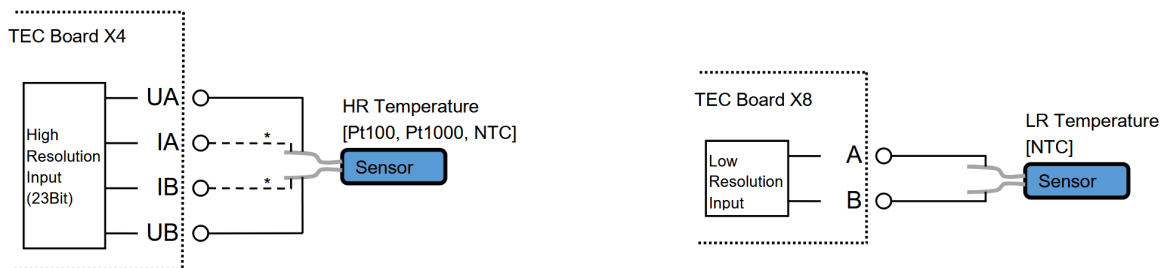

* In case of Pt100 or Pt1000, use 4 wires to connect the High Resolution Temperature Sensor

Further information can be found [here](#).

5 MECHANICAL DATA

5.1 Dimensions

- TEC-1161-4A SCREW: 77 × 48 × 19 mm
- TEC-1161-4A PIN: 77 × 48 × 19.8 mm
- TEC-1161-10A SCREW: 77 × 48 × 22.2 mm
- TEC-1161-10A PIN: 77 × 48 × 19.8 mm

Top View

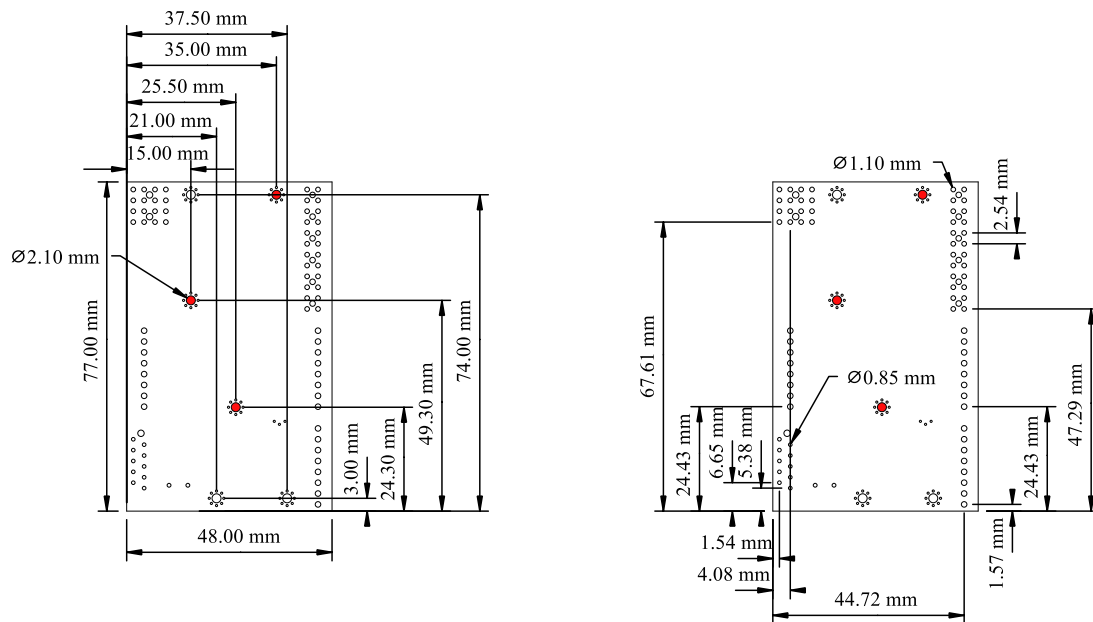

The holes marked in red are used to mount the aluminum baseplate for the -10A version and are therefore not available for mounting purposes in this version.

Be aware that the -10A version has a baseplate for cooling!

6 ORDERING AND CONFIGURATION

6.1 TEC-1161 Ordering Information & Configuration

Example Configuration:

TEC-1161 (4A, NTC, SCREW) FW6.31

Variant Name	Requirement	Description	Options / Single choice
Current	Required	Select the maximum output current per channel.	4A, 10A
High Resolution Sensor Type ¹	Required	Select the temperature sensor type for the HR input.	PT100, PT1000, NTC, VIN1, VIN2
Terminal Configuration ¹	Required	Select connector type.	NC, SCREW, PIN
Firmware Version	Optional	Select a compatible firmware if you do not want the latest version (default). Check the relevant Software Release Notes for details.	Example: FW6.31
Customer Specific Modifications	Advanced	Usually hardware modifications, available only on demand and quote.	Empty, or example: CS3
Customer Specific Profile	Advanced	Preset parameters/configuration, available only on demand and quote.	Empty, or example: 15
Hardware Version	-	For reference, specifies the hardware version (latest by default, subject to future change).	Example: HW1.30

¹ See also Chapter 3.3: Hardware Configuration

6.2 Ordering Confirmation Example

TEC-1161 (4A, NTC, SCREW, HW1.30)

Firmware Version: FW6.31

String can additionally contain:

Profile: Default

7 ALL MEERSTETTER ENGINEERING PRODUCTS

7.1 Meerstetter Engineering's Product Compatibility

The Laser Diode Drivers and TEC Controllers from Meerstetter have been developed to work along with each other. They share the same platform bus, communication protocol and hardware architecture. See the following table for an overview of the Laser Diode Drivers and TEC Controllers from Meerstetter Engineering:

Model	Output	Description	
Laser Diode Drivers			
LDD-1321	0–1.5 A / 0–14 V	CW, Add-on TEC Controller available	
LDD-1301	0–20 A / 0.5–45 V	1 ms – CW	
LDD-1303	0–20 A / 1–120 V	1 ms – CW	
LDD-1137	0–75 A / 0–70 V	1 ms – CW	
LDD-1124	0–1.5 A / 0–15 V	CW, modulated modes	
LDD-1121	0–15 A / 0–15 V	1 μ s – CW, modulated, QCW and pulsed modes	
LDD-1125	0–30 A / 0–27 V	1 μ s – CW, modulated, QCW and pulsed modes	
TEC Controllers			
Single-Channel Models	TEC-1092	± 1.2 A / ± 9.6 V	Micro
	TEC-1091	± 4 A / ± 21 V	Small
	TEC-1089	± 10 A / ± 21 V	Medium
	TEC-1162	± 5 A / ± 56 V	Medium-high
	TEC-1090	± 16 A / ± 30 V	Large
	TEC-1163	± 25 A / ± 56 V	Extra-large
Dual-Channel Models	TEC-1161-4A	2 x (± 4 A / ± 21 V)	Small
	TEC-1161-10A	2 x (± 10 A / ± 21 V)	Medium
	TEC-1122	2 x (± 10 A / ± 21 V)	Medium
	TEC-1166	2 x (± 5 A / ± 56 V)	Medium-high
	TEC-1123	2 x (± 16 A / ± 30 V)	Large
	TEC-1167	2 x (± 25 A / ± 56 V)	Extra-large

8 CHANGE HISTORY

Date of change	Version	Changed / Approved	HW Version
October 14, 2024	G	XF / ML	v1.20 / v1.21
Change / Reason <ul style="list-style-type: none"> • Add: Change History • Add: New Main Feature: Measurement Inputs are freely assignable to any Output Channel • Add: New Main Feature: Bipolar output channels can be split into unipolar channels • Add: “Unipolar current per channel” and “Unipolar voltage per channel” specifications in “Electrical Characteristics” section • Add: Max Input Current (I_{IN}) specification in Electrical Characteristics section • Del: “Important note” regarding GPIO 9/10 and Low resolution temp. measurement 3/4 not being available removed as they are available as of firmware v6.00 			
February 12, 2026	H	ML / SR	v1.30
Change / Reason <ul style="list-style-type: none"> • Mod: Hardware Version changed to v1.30 • Mod: Max. Output Current vs System Base Plate Temp. 10A Model: X Axis Title changed 			
April 20, 2026	I	NJ / HS/SR	v1.30
Change / Reason <ul style="list-style-type: none"> • Mod: Datasheet design • Del: Old Ordering codes • Add: Standardized product designations and ordering codes tables • Add: Typical Application Chapter • Add: Typ/Max output voltage (U_{OH}) for GPO pins 			

MEERSTETTER ENGINEERING GMBH

Schulhausgasse 12
3113 Rubigen, Switzerland

+41 31 529 21 00

contact@meerstetter.ch

<https://www.meerstetter.ch/>

Meerstetter Engineering GmbH (ME) reserves the right to make changes without further notice to the product described herein. Information furnished by ME is believed to be accurate and reliable. However typical parameters can vary depending on the application and actual performance may vary over time. All operating parameters must be validated by the customer under actual application conditions.