

TEC-1122

Hardware Version v2.00

The **TEC-1122** is a high-precision dual-channel thermoelectric controller designed for driving and monitoring Peltier elements with exceptional accuracy & stability. Featuring fully digital control, intelligent PID auto-tuning, and comprehensive communication interfaces, it offers a complete solution for demanding temperature-controlled applications. Optional Advanced Features such as Cascade Temperature Control, Channel Splitting and Temperature Estimation are available through Software.

HIGHLIGHTS

- **Output per Channel:** variable up to ± 10 A, ± 21 V
- **Input Voltage:** 12 – 24 VDC
- Typical cooling capacity: 2×105 W (@COP=0.5)
- Temperature precision/stability: ≤ 0.01 °C
- Control Frequency: 1 Hz, 10 Hz, 80 Hz
- Dimensions: 120 × 90 × 18 mm
- Digital PID control with auto-tuning
- Smooth temperature ramping and thermal stability indicator
- Stand-alone or remote-controlled operation via USB (isolated) or RS485
- GUI software for configuration and data logging
- Supports Pt100, Pt1000, NTC or Voltage sensors (4-wire precision input). The analog measurement circuit is factory calibrated
- GPIO features for monitoring and control (Enable, Error Indication, Fan Control, etc.)
- Two independent channels for individual or common loads
- Supports Peltier elements and resistive heaters

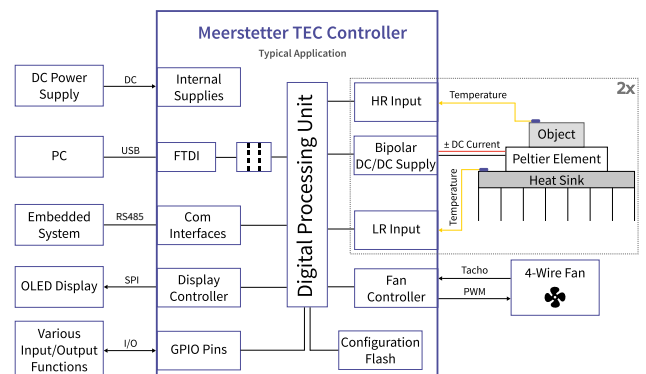

Trial Device & Technical Support

Trial devices and technical support are available for evaluation projects. Please contact support@meerstetter.ch or visit our [support center](#).

RELATED PRODUCTS

Model	Channels	Output per Channel	Description
TEC-1161-10A	2	± 10 A / ± 21 V	recommended for new designs
TEC-1163	1	± 25 A / ± 56 V	single-channel alternative
TEC-1167	2	± 25 A / ± 56 V	higher power
TEC-1161-4A	2	± 4 A / ± 21 V	more compact, lower power

See the [full product overview](#) in the Meerstetter Engineering's Product Compatibility section.

TABLE OF CONTENTS

1	Specifications	3
1.1	Absolute Maximum Ratings.....	3
1.2	Operating Characteristics for Firmware \geq v4.00	3
1.3	Operating Characteristics for Firmware $<$ v4.00	4
1.4	Electrical Characteristics.....	5
1.5	Output Safety Characteristics	5
2	Temperature Characteristics	6
2.1	High Resolution Temperature Measurement Characteristics (Pt100 and Pt1000 Probes)	6
2.2	High Resolution Temperature Measurement Characteristics (NTC Probes)	6
2.3	High Resolution Temperature Measurement Characteristics (Voltage Measurement VIN1)	6
2.4	Low Resolution Temperature Measurement Characteristics (NTC only)	6
3	Functional Description	7
3.1	Typical Application	7
3.2	Operation Modes and Communication Options	8
3.3	Hardware Configuration	8
4	Interface and Connectors	9
4.1	General Purpose Digital I/O Characteristics (GPIO1 ... GPIO8).....	9
4.2	Package Outline and Pin Configuration	10
5	Ordering and Configuration	11
5.1	TEC-1122 Ordering Information & Configuration	11
5.2	Ordering Confirmation Example	11
6	All Meerstetter Engineering Products	12
6.1	Meerstetter Engineering's Product Compatibility	12
7	Change History	13

1 SPECIFICATIONS

1.1 Absolute Maximum Ratings ¹

		Min	Max	Unit
Voltage	U _{IN, DC}		27	V
	U _{IN, GPIO}	-0.5	5.5	V

¹ Operation at or beyond the absolute maximum ratings may result in permanent device damage. These limits are stress ratings only and functional operation of the device at these conditions is not guaranteed. Prolonged exposure to absolute maximum conditions can adversely affect long-term reliability and should be avoided during normal operation.

1.2 Operating Characteristics for Firmware \geq v4.00

		Min	Max	Unit
Temperature	T _{OP}	-40	90	°C
Humidity	RH _{OP, non-condensing}	5	95	%

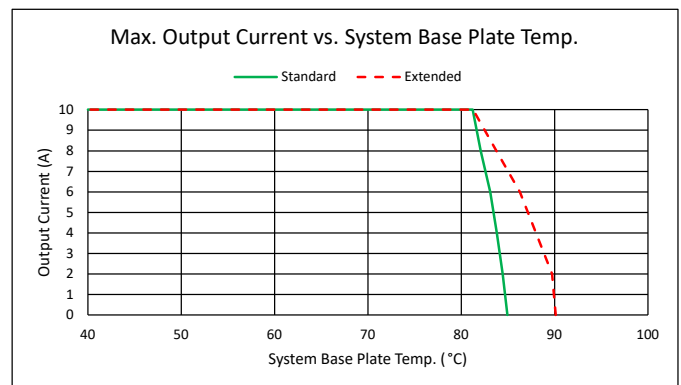
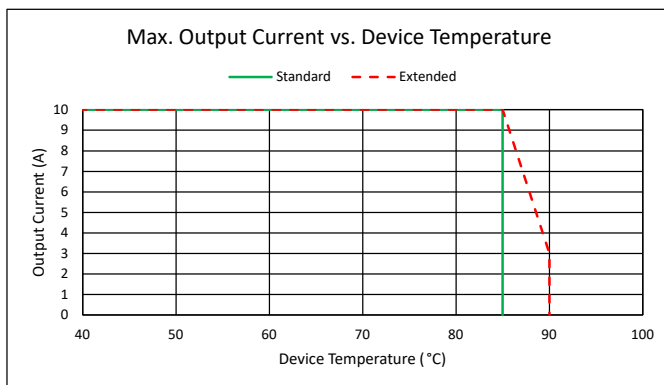

Additional information about the charts above:

- Standard or Extended device temperature mode can be set as a software setting.
 - In standard mode, the device throws an error and switches off if the maximal device temperature is reached.
 - In extended mode, the device first reduces the maximum output current before it throws an error and switches off.
- The Device Temperature is the temperature which is being measured by the TEC Controller itself on its own PCB. This is the temperature which is relevant for the overtemperature behavior (left chart).
- The System Base Plate is assumed as the customers heatsink where the TEC Controller is mounted to. The right diagram shows the maximum temperature of the customers heatsink to not exceed the temperatures in the left diagram under the following conditions:
 - Between the TEC Controllers base plate and the customers heatsink this thermal pad: Bergquist: “GP1500R-0.010-02-0816” was used. We recommend employing this or a similar product.
 - The TEC Controller is pressed with 1.2kPa to the System Base Plate. It is recommended to use the mounting holes of the TEC Controller to press the TEC Controller to the System Base Plate.
 - The air ambient temperature was approximately 30°C colder than the System Base Plate.

1.3 Operating Characteristics for Firmware < v4.00

		Min	Max	Unit
Temperature	T _{OP}	-40	85	°C
Humidity	RH _{OP} , non-condensing	5	95	%

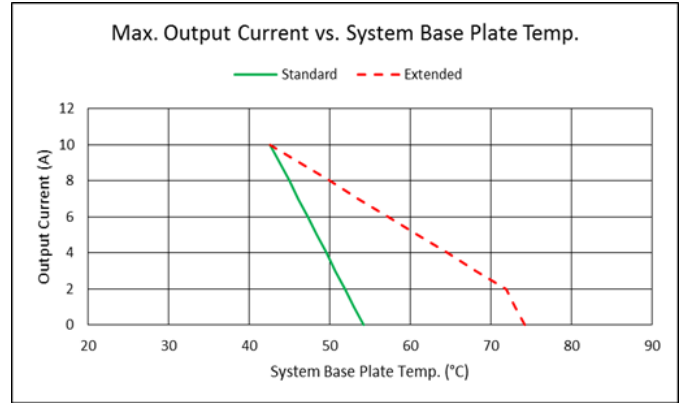
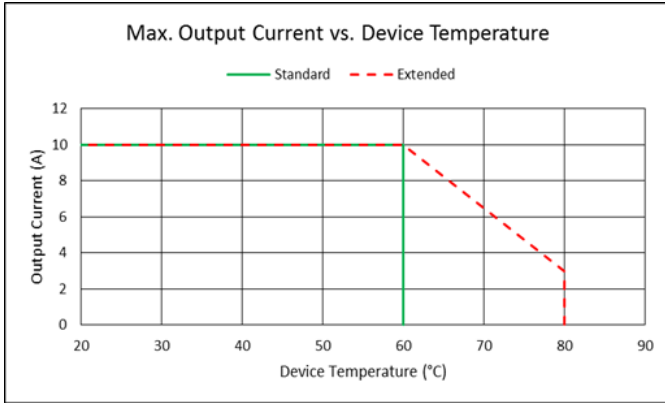

Test Condition:

TEC Controller pressed with 1.2 kPa to an aluminum System Base Plate without any thermal conductivity material in between. Using a good thermal conductivity material is recommended for high output currents. Standard or Extended Device Temperature Mode can be set as software setting.

1.4 Electrical Characteristics

Unless otherwise noted: $T_A = 25^\circ\text{C}$, $U_{IN} = 24\text{ V}$, $R_{load} = 1.75\ \Omega$, $FW \geq v4.00$

Symbol	Parameter	Test Conditions / Hints	Min	Typ	Max	Units
DC Power Supply Input:						
U_{IN}	Supply voltage	Measured directly on power input terminals	11.5	24	25.5	V
U_{IN} Ripple	Ripple tolerance	U_{IN} never below U_{IN} min or above U_{IN} max			300	mV _{PP}
I_{IN}	Max input current	Hint: Software limitation			20	A
Output (per Channel):						
I_{OUT}	Bipolar current				± 10	A
U_{OUT}	Bipolar voltage	U_{IN} at least 4 V greater than U_{OUT} Measured directly on power output terminals			± 21	V
I_{OUT}	Unipolar current ¹				10	A
U_{OUT}	Unipolar voltage ¹	U_{IN} at least 4 V greater than U_{OUT} Measured directly on power output terminals			21	V
U_{OUT} Ripple	Voltage ripple	$R_{load} = 1.13\ \Omega$, 10 A		90		mV _{PP}
System Characteristics:						
$\eta_{50\%}$	Power efficiency	@ 50% load (10.5 V, 10 A per channel)		93		%
$\eta_{100\%}$	Power efficiency	@ 100% load (21 V, 10 A per channel)		96		%
Output Monitoring: (I_{OUT} Resolution is 7.3 mA; U_{OUT} Resolution is 8.8 mV)						
I_{OUT} Read	Precision	@ 9.5 A		1	5	%
U_{OUT} Read	Precision	@ 15.0 V		1	3	%

¹ In unipolar mode, the total output power is doubled in comparison to the bipolar mode, but the controller input current is limited to I_{IN} , which limits the total available output power. The controller limits the output current for each channel dynamically if the max input current limit is reached.

1.5 Output Safety Characteristics

Unless otherwise noted: $T_A = 25^\circ\text{C}$, $U_{IN} = 24\text{ V}$

Symbol	Parameter	Test Conditions / Hints	Min	Typ	Max	Unit
Output Stage Protection Delays:						
t_{OFF}	Short circuit	Full load condition		10	30	μs
t_{OFF}	Power system limits	Current and voltage limits			200	μs
Output Stage Current Supervision: (If the OUT+ and OUT- currents differ too much, an error is generated)						
I_{OUT_DIFF}	Error threshold			1		A

2 TEMPERATURE CHARACTERISTICS

2.1 High Resolution Temperature Measurement Characteristics (Pt100 and Pt1000 Probes)

Measurement configuration = 23 bit / 4-wire / unshielded cable < 50 mm

Symbol	Parameter	Test Conditions / Hints	Min	Typ	Max	Unit
$T_{HR, RANGE}$	Range	Range is extendable upon request Default measurement range is -220°C ... +200°C Extended measurement range is -193°C ... +787°C	-100		200	°C
$T_{HR, PREC}$	Precision	(EN 60751 / IEC 751)		0.005	0.01	°C
$T_{HR, COEFF}$	Temp. Coefficient	Relative to device temperature			1.6 m	°C/K
$T_{HR, NOISE}$	Value Noise	Reference measurement fluctuations while output stage operating @70% load		0.003		°C
$T_{HR, REP}$	Repeatability	Repeated measurements of reference resistors after up to 3 days		0.005		°C

2.2 High Resolution Temperature Measurement Characteristics (NTC Probes)

NTC thermistor resistive input characteristics translate into temperature ranges valid for only one type of NTC probe. Below example is given in the case of an NTC B_{25/100} 3988K R₂₅ 10k temperature sensor.

Symbol	Parameter	Test Conditions / Hints	Min	Typ	Max	Unit
$R_{HR, RANGE}^1$	ADC Gain PGA = 1	Low-°T Configuration NTC56K	3360 ≈ 51.8		55720 ≈ -10.1	Ω °C
$R_{HR, RANGE}^1$	ADC Auto Gain PGA = 1 or 8	High-°T Configuration NTC18K	135 ≈ 164.0		17910 ≈ 12.2	Ω °C
		Mid-°T Configuration NTC39K	293 ≈ 131.0		38805 ≈ -3.4	Ω °C
		Very Low-°T Configuration NTC1M	293 ≈ 131.0		1M ≈ -55.5	Ω °C

¹ $R_{HR, RANGE}$ is the resistance range of the NTC sensor

2.3 High Resolution Temperature Measurement Characteristics (Voltage Measurement VIN1)

Sensors with linear Voltage/Temperature output

Symbol	Parameter	Test Conditions / Hints	Min	Typ	Max	Unit
$U_{SENS, DIFF}$	Range	Differential input voltage Temperature range depends on sensor used	-2.039		2.039	V
$U_{HRUX, ABS}$	Range	Absolute input voltage	0.1		3.2	V

2.4 Low Resolution Temperature Measurement Characteristics (NTC only)

$T_A = 25^\circ\text{C}$, measurement configuration = 12 bit / 2-wire / unshielded cable < 50 mm, °T probe = NTC B_{25/100} 3988K R₂₅ 10k

Symbol	Parameter	Test Conditions / Hints	Min	Typ	Max	Unit
$R_{LR, RANGE}$	Range		180 ≈ 150		44600 ≈ -6.0	Ω °C

3 FUNCTIONAL DESCRIPTION

3.1 Typical Application

Following image gives an overview of a typical thermoelectric cooling (TEC) application using a Meerstetter Engineering TEC Controller to drive a [thermoelectric heat pump](#), often also referred to as Peltier element.

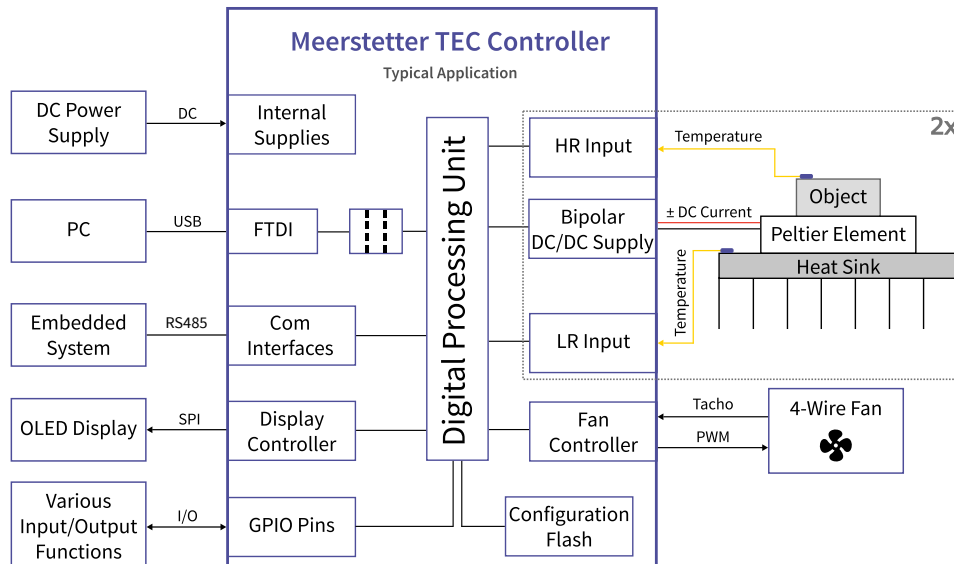

A bipolar DC/DC converter supplies power the Peltier element in unipolar directions. This enables both heating and cooling of the object. A 23-bit high-resolution (HR) measurement input continuously measures the object temperature. Using the acquired temperature, the object temperature is controlled and held stable (deviation is typically 0.01 °C or less) by adjusting the heat pumping capacity.

Waste heat from the object is pumped to a heat sink and further radiated into the environment. A low-resolution (LR) input monitors the temperature of the heat sink to further optimize the control algorithm (not required but recommended). Optional fans enable controlling the sink temperature through forced air removal. The TEC Controller features two separate 4-Wire fan interfaces with integrated fan control.

Once configured, the device operates standalone by storing its configuration parameters in internal non-volatile flash storage. The configuration can be changed by using our [configuration software](#) or [MeComAPI](#) through the isolated USB port or RS-interfaces.

Please ensure that the device supports your required communication interface and refer to the [Remote Control Guide](#) for more detailed information.

For easy on-site status information, an OLED display can be connected to show any parameter by freely setting it up through software.

The controller supports various GPIO functionalities for monitoring and controlling of the device. Features include Driver Enable, Error Indication, Fan Control & Pump Enable, Temperature Stable Indication, Temperature Increment/Decrement and more. Most functions can be freely assigned to any GPIO.

i For more information on the operation of the device and the Peltier elements, as well as how to dimension them, please refer to the [compendium](#) on our website.

3.2 Operation Modes and Communication Options

The TEC-1122 is an OEM two-channel TEC Controller that is primarily designed to operate as a stand-alone device. Its basic operation status is visually indicated by on-board green and red LEDs and their blinking pattern. More detailed status information can be polled at any time by industry standard RS485 connection or by USB. The TEC-1122 can also operate in a remote-controlled manner, with parameters adjusted on the fly. Scripting capability by sequential lookup table read-out is supported.

Configured as a DC power-supply, the TEC-1122 can handle current and voltage settings. In the remote-control case, temperature data may be passed on to be processed by the host. Also, the TEC Controller's two channels can be configured to operate in a 'parallel' mode to double the output current.

Configurable parameters further include sensor linearization (Pt100 / Pt1000) and Steinhart-Hart modeling (NTC), temperature acquisition hardware calibration, Peltier element modeling, PID controller auto tuning, nominal temperature ramping, current, voltage and temperature limits, error thresholds, etc. Please refer to the TEC Controller User Manual (Document 5216) for further information.

3.3 Hardware Configuration

High Resolution Sensor Type:

NTC: By default, we mount an NTC1M. If you require an older version (NTC18K, NTC39K or NTC56K), please write which one you need in the comment section of your order or contact us: contact@meerstetter.ch.

Thermocouple:

To use our TEC Controllers with thermocouples type K, you need a TCI-1181 in addition to the TEC Controller with a VIN1 High Resolution Sensor Type configuration.

Display Unit:

It is possible to connect a small or big OLED 2x16 / 4x20 character display directly to the X11 connector of the device. Please visit the [DPY-111x](#) product pages on our website for further information.

Customization:

Many hardware and software features of the TEC-1122 are customizable upon request. Please contact Meerstetter Engineering with your enquiry.

4 INTERFACE AND CONNECTORS

4.1 General Purpose Digital I/O Characteristics (GPIO1 ... GPIO8)

Unless otherwise noted: $T_A = 25^\circ\text{C}$, $U_{IN} = 24\text{ V}$

Symbol	Parameter	Test Conditions / Hints	Min	Typ	Max	Units
Input Characteristics:						
U_{IH}	Logic high input threshold		2.38			V
U_{IL}	Logic low input threshold				0.93	V
U_{IMAX}	Maximum input voltage	General Purpose Inputs are 5V-tolerant	-0.5		5.5	V
Output Characteristics: (Microprocessor)						
U_{OH}	Logic high output voltage	Output current 8 mA	2.8	3.3	3.4	V
U_{OL}	Logic low output voltage	Input current 8 mA			0.4	V
ESD Protection: (Between Processor and Connector)						
U_{PP}	ESD discharge	IEC61000-4-2			100	kV
R_A	Series resistance		170	200	230	Ω

4.2 Package Outline and Pin Configuration

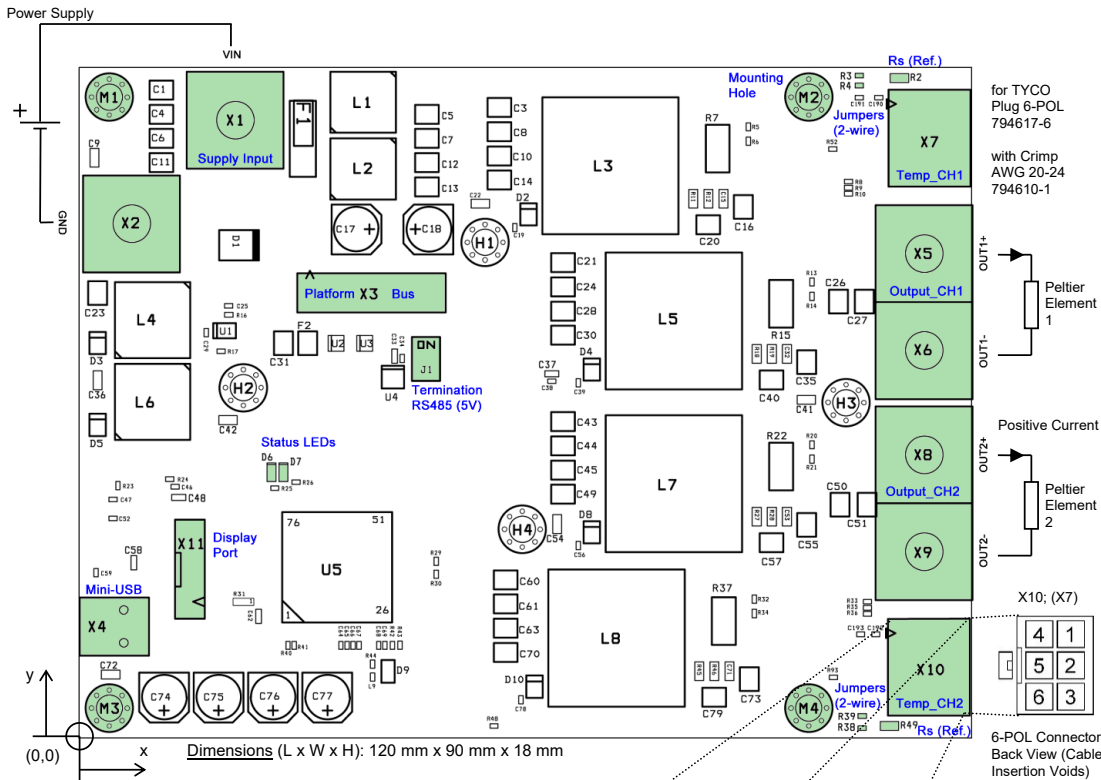

Mounting (4x 3.2 mm Holes, 7.6 mm in Length):

- M1: x = 4.0 mm, y = 86.0 mm
- M2: x = 98.0 mm, y = 86.0 mm
- M3: x = 4.0 mm, y = 4.0 mm
- M4: x = 98.0 mm, y = 4.0 mm

Pin Description Platform Bus X3:
TYCO Plug 14-POL: 8-215083-4

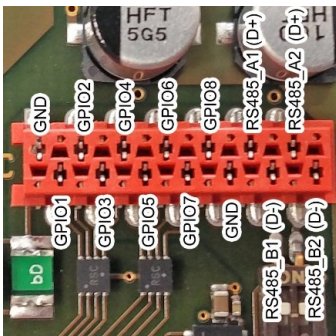

TEC Board X7, X10

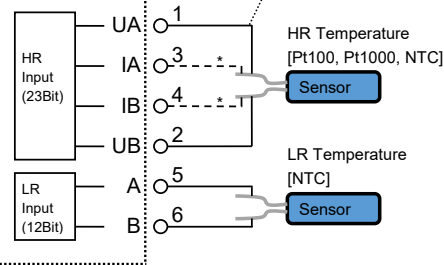

* In case of Pt100 or Pt1000, use 4 wires to connect the High Resolution Temperature Sensor

Pin Description Platform Bus X3 (cont.):

- GND: fused with 200 mA polyfuse; -HV 100 mA
- DIP-switch J1, 1: 120 Ω termination for RS485 1
- DIP-switch J1, 2: 120 Ω termination for RS485 2

Power Terminals: M4-size Screws

Peltier element, temperature probes, power supply and connectors not included.

5 ORDERING AND CONFIGURATION

5.1 TEC-1122 Ordering Information & Configuration

Example Configuration:

TEC-1122 (NTC) FW6.31

Variant Name	Requirement	Description	Options / Single choice
High Resolution Sensor Type¹	Required	Select the temperature sensor type for the HR input.	PT100, PT1000, NTC, VIN1
Firmware Version	Optional	Select a compatible firmware if you do not want the latest version (default). Check the relevant Software Release Notes for details.	Example: FW6.31
Gap Pad	Advanced	Select a Gap Pad variant, custom versions available only on demand and quote. DE: default	DE, or example: SF
Customer Specific Modifications	Advanced	Usually hardware modifications, available only on demand and quote.	Empty, or example: CS3
Customer Specific Profile	Advanced	Preset parameters/configuration, available only on demand and quote.	Empty, or example: 15
Hardware Version	-	For reference, specifies the hardware version (latest by default, subject to future change).	Example: HW2.00

¹ See also Chapter 3.3: Hardware Configuration

5.2 Ordering Confirmation Example

TEC-1122 (NTC, NA, HW2.00)

Firmware Version: FW6.31

String can additionally contain:

Profile: Default

6 ALL MEERSTETTER ENGINEERING PRODUCTS

6.1 Meerstetter Engineering's Product Compatibility

The Laser Diode Drivers and TEC Controllers from Meerstetter have been developed to work along with each other. They share the same platform bus, communication protocol and hardware architecture. See the following table for an overview of the Laser Diode Drivers and TEC Controllers from Meerstetter Engineering:

Model	Output	Description	
Laser Diode Drivers			
LDD-1321	0–1.5 A / 0–14 V	CW, Add-on TEC Controller available	
LDD-1301	0–20 A / 0.5–45 V	1 ms – CW	
LDD-1303	0–20 A / 1–120 V	1 ms – CW	
LDD-1137	0–75 A / 0–70 V	1 ms – CW	
LDD-1124	0–1.5 A / 0–15 V	CW, modulated modes	
LDD-1121	0–15 A / 0–15 V	1 μ s – CW, modulated, QCW and pulsed modes	
LDD-1125	0–30 A / 0–27 V	1 μ s – CW, modulated, QCW and pulsed modes	
TEC Controllers			
Single-Channel Models	TEC-1092	± 1.2 A / ± 9.6 V	Micro
	TEC-1091	± 4 A / ± 21 V	Small
	TEC-1089	± 10 A / ± 21 V	Medium
	TEC-1162	± 5 A / ± 56 V	Medium-high
	TEC-1090	± 16 A / ± 30 V	Large
	TEC-1163	± 25 A / ± 56 V	Extra-large
Dual-Channel Models	TEC-1161-4A	2 x (± 4 A / ± 21 V)	Small
	TEC-1161-10A	2 x (± 10 A / ± 21 V)	Medium
	TEC-1122	2 x (± 10 A / ± 21 V)	Medium
	TEC-1166	2 x (± 5 A / ± 56 V)	Medium-high
	TEC-1123	2 x (± 16 A / ± 30 V)	Large
	TEC-1167	2 x (± 25 A / ± 56 V)	Extra-large

7 CHANGE HISTORY

Date of change	Version	Changed / Approved	HW Version
October 14, 2024	Z	XF / ML	v2.00
Change / Reason <ul style="list-style-type: none"> • Add: Change History • Add: New Main Feature: Measurement Inputs are freely assignable to any Output Channel • Add: New Main Feature: Bipolar output channels can be split into unipolar channels • Add: “Unipolar current per channel” and “Unipolar voltage per channel” specifications in “Electrical Characteristics” section • Add: Max Input Current (I_{IN}) specification in Electrical Characteristics section • Mod: Changed naming of “Main”/“Object” measurement input to “High Resolution” measurement input • Mod: Changed naming of “Auxiliary”/“Sink” measurement input to “Low Resolution” measurement input • Mod: Specified that the RS485 Data Interfaces only support Half-Duplex communication • Del: RS422 communication is not supported • Del: “Bipolar output current” and “Bipolar output voltage” removed from “Absolute Maximum Ratings” section • Del: “TEC Service Software” and “Temperature Control (Autotuned PID)” sections removed 			
April 17, 2026	AA	NJ / HS/SR	v2.00
Change / Reason <ul style="list-style-type: none"> • Mod: Datasheet design • Del: Old Ordering codes • Add: Standardized product designations and ordering codes tables • Add: Typical Application Chapter • Add: Typ/Max output voltage (U_{OH}) for GPO pins 			

MEERSTETTER ENGINEERING GMBH

Schulhausgasse 12
3113 Rubigen, Switzerland

+41 31 529 21 00

contact@meerstetter.ch

<https://www.meerstetter.ch/>

Meerstetter Engineering GmbH (ME) reserves the right to make changes without further notice to the product described herein. Information furnished by ME is believed to be accurate and reliable. However typical parameters can vary depending on the application and actual performance may vary over time. All operating parameters must be validated by the customer under actual application conditions.