

TEC-1092

Hardware Version v1.10

The **TEC-1092** is a high-precision single-channel thermoelectric controller designed for driving and monitoring Peltier elements with exceptional accuracy & stability. Featuring fully digital control, intelligent PID auto-tuning, and comprehensive communication interfaces, it offers a complete solution for demanding temperature-controlled applications. Optional Advanced Features such as Cascade Temperature Control, Channel Splitting and Temperature Estimation are available through Software.

HIGHLIGHTS

- **Output:** variable up to $\pm 1.2\text{ A}$, $\pm 9.6\text{ V}$
- **Input Voltage:** 5 – 12 VDC
- Typical cooling capacity: **6 W** (@COP=0.5)
- Temperature precision/stability: $\leq 0.01\text{ }^\circ\text{C}$
- Control Frequency: 1 Hz, 10 Hz, 90 Hz
- Dimensions: 36 × 28 × 8.5 mm
- Digital PID control with auto-tuning
- Smooth temperature ramping and thermal stability indicator
- Stand-alone or remote-controlled operation via RS485 or RS232 TTL
- GUI software for configuration and data logging
- Supports Pt100, Pt1000, NTC or Voltage sensors (4-wire precision input). The analog measurement circuit is factory calibrated
- GPIO features for monitoring and control (Enable, Error Indication, Fan Control, etc.)
- Supports Peltier elements and resistive heaters
- Available as compact PCB-mount OEM module featuring a board-to-board mezzanine connector

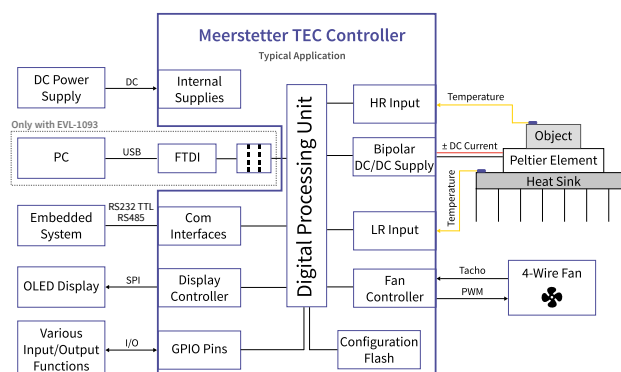

Trial Device & Technical Support

Trial devices and technical support are available for evaluation projects. Please contact support@meerstetter.ch or visit our [support center](#).

RELATED PRODUCTS

Model	Channels	Output per Channel	Description
EVL-1093	-	-	matching evaluation adapter
TEC-1091	1	$\pm 4\text{ A} / \pm 21\text{ V}$	higher power
TEC-1161-4A	2	$\pm 4\text{ A} / \pm 21\text{ V}$	dual-channel alternative, higher power
TEC-1161-10A	2	$\pm 10\text{ A} / \pm 21\text{ V}$	dual-channel alternative, higher power

See the [full product overview](#) in the Meerstetter Engineering's Product Compatibility section.

TABLE OF CONTENTS

1 Specifications	3
1.1 Absolute Maximum Ratings.....	3
1.2 Operating Characteristics.....	3
1.3 Electrical Characteristics.....	4
1.4 Output Safety Characteristics	4
2 Temperature Characteristics	5
2.1 High Resolution Temperature Measurement Characteristics (Pt100 and Pt1000 Probes)	5
2.2 High Resolution Temperature Measurement Characteristics (NTC Probes)	5
2.3 High Resolution Temperature Measurement Characteristics (Voltage Measurement VIN1)	5
2.4 Low Resolution Temperature Measurement Characteristics (NTC only)	5
3 Functional Description	6
3.1 Typical Application	6
3.2 Operation Modes and Communication Options	7
3.3 Hardware Configuration	7
4 Interface and Connectors	8
4.1 RS232 TTL and General Purpose Digital I/O Characteristics (GPIO1 ... GPIO8, RX, TX).....	8
4.2 Package Outline and Pin Configuration	8
4.3 Pin Description X1	9
4.4 Temperature Sensor Connection X1	9
5 Ordering and Configuration	10
5.1 TEC-1092 Ordering Information & Configuration	10
5.2 Ordering Confirmation Example	10
6 All Meerstetter Engineering Products	11
6.1 Meerstetter Engineering's Product Compatibility	11
7 Change History	12

1 SPECIFICATIONS

1.1 Absolute Maximum Ratings¹

		Min	Max	Unit
Voltage	U _{IN, DC}		20	V
	U _{IN, GPIO}	-0.5	5.5	V

¹ Operation at or beyond the absolute maximum ratings may result in permanent device damage. These limits are stress ratings only and functional operation of the device at these conditions is not guaranteed. Prolonged exposure to absolute maximum conditions can adversely affect long-term reliability and should be avoided during normal operation.

1.2 Operating Characteristics

		Min	Max	Unit
Temperature	T _{OP}	-40	90	°C
Humidity	RH _{OP, non-condensing}	5	95	%

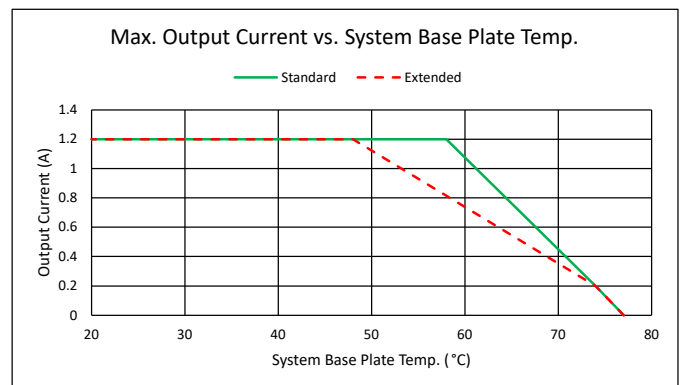
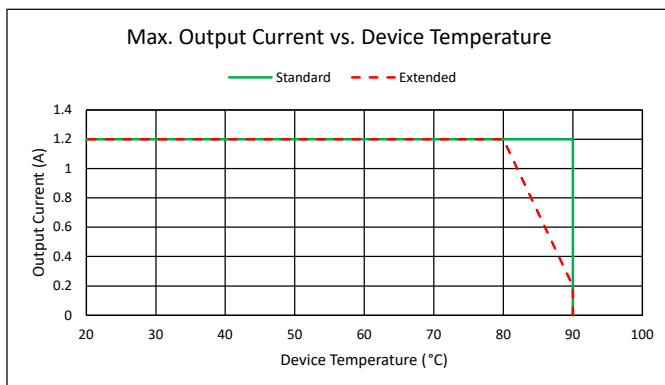

Standard or Extended Device Temperature Mode can be set as software setting.

The right Diagram shows the situation with an external 7.5 Ω resistor. TEC Controller mounted on the EVL-1093 and supplied with 12 V. No forced air flow was present.

1.3 Electrical Characteristics

Unless otherwise noted: $T_A = 25\text{ °C}$, $U_{IN} = 12\text{ V}$, $R_{load} = 7.5\ \Omega$

Symbol	Parameter	Test Conditions / Hints	Min	Typ	Max	Units
DC Power Supply Input:						
U_{IN}	Supply voltage	Measured directly on power input terminals	4.9		12.5	V
I_{IN}	Max input current	Hint: Software limitation			1.5	A
Output (per Channel):						
I_{OUT}	Bipolar current				± 1.2	A
U_{OUT}	Bipolar voltage	U_{OUT} is maximum $\sim 0.9 \cdot U_{IN}$			± 9.6	V
I_{OUT}	Unipolar current ¹				1.2	A
U_{OUT}	Unipolar voltage ¹	U_{OUT} is maximum $\sim 0.9 \cdot U_{IN}$			9.6	V
U_{OUT} Ripple	Voltage ripple	@ 1.2 A		25		mV _{PP}
I_{OUT} Drift	Output current temperature drift			0.1		mA/°C
System Characteristics:						
$\eta_{50\%}$	Power efficiency	@ 50% load		85		%
$\eta_{90\%}$	Power efficiency	@ 90% load		88		%
Output Monitoring: (I_{OUT} resolution is 732 μ A; U_{OUT} resolution is 4.15 mV)						
I_{OUT} Read	Precision	@ 1.2 A		1	5	%
U_{OUT} Read	Precision	@ 9.6 V		1	3	%

¹ In unipolar mode, the total output power is doubled in comparison to the bipolar mode, but the controller input current is limited to I_{IN} , which limits the total available output power. The controller limits the output current for each channel dynamically if the max input current limit is reached.

1.4 Output Safety Characteristics

Unless otherwise noted: $T_A = 25\text{ °C}$, $U_{IN} = 12\text{ V}$

Symbol	Parameter	Test Conditions / Hints	Min	Typ	Max	Units
Output Stage Protection Delays:						
t_{OFF}	Short circuit	Full load condition		10	30	μ s
t_{OFF}	Power system limits	Current and voltage limits			200	μ s
Output Stage Current Supervision: (If the OUT+ and OUT- currents differ too much, an error is generated)						
I_{OUT_DIFF}	Error threshold			120		mA

2 TEMPERATURE CHARACTERISTICS

2.1 High Resolution Temperature Measurement Characteristics (Pt100 and Pt1000 Probes)

Measurement configuration = 23 bit / 4-wire / unshielded cable < 50 mm

Symbol	Parameter	Test Conditions / Hints	Min	Typ	Max	Unit
$T_{HR, RANGE}$	Range	Range is extendable upon request Default measurement range is -220°C ... +200°C Extended measurement range is -193°C ... +787°C	-100		200	°C
$T_{HR, PREC}$	Precision	(EN 60751 / IEC 751)		0.005	0.01	°C
$T_{HR, COEFF}$	Temp. Coefficient	Relative to device temperature			1.6 m	°C/K
$T_{HR, NOISE}$	Value Noise	Reference measurement fluctuations while output stage operating @70% load		0.003		°C
$T_{HR, REP}$	Repeatability	Repeated measurements of reference resistors after up to 3 days		0.005		°C

2.2 High Resolution Temperature Measurement Characteristics (NTC Probes)

NTC thermistor resistive input characteristics translate into temperature ranges valid for only one type of NTC probe. Below example is given in the case of an NTC B_{25/100} 3988K R₂₅ 10k temperature sensor.

Symbol	Parameter	Test Conditions / Hints	Min	Typ	Max	Unit
$R_{HR, RANGE}^1$	ADC Auto Gain PGA = 1 or 8 or 32	Very Low-°T Configuration NTC	73 ≈ 194.3		1M ≈ -55.5	Ω °C

¹ $R_{HR, RANGE}$ is the resistance range of the NTC sensor

2.3 High Resolution Temperature Measurement Characteristics (Voltage Measurement VIN1)

Sensors with linear Voltage/Temperature output.

Symbol	Parameter	Test Conditions / Hints	Min	Typ	Max	Unit
$U_{SENS, DIFF}$	Range	Differential input voltage Temperature range depends on sensor used	-2.039		2.039	V
$U_{HRUX, ABS}$	Range	Absolute input voltage	-0.1		5.1	V

2.4 Low Resolution Temperature Measurement Characteristics (NTC only)

$T_A = 25\text{ °C}$, measurement configuration = 12 bit / 2-wire / unshielded cable < 50 mm, °T probe = NTC B_{25/100} 3988K R₂₅ 10k

Symbol	Parameter	Test Conditions / Hints	Min	Typ	Max	Unit
$R_{LR, RANGE}$	Range		180 ≈ 150.0		44600 ≈ -6.0	Ω °C

3 FUNCTIONAL DESCRIPTION

3.1 Typical Application

Following image gives an overview of a typical thermoelectric cooling (TEC) application using a Meerstetter Engineering TEC Controller to drive a [thermoelectric heat pump](#), often also referred to as Peltier element.

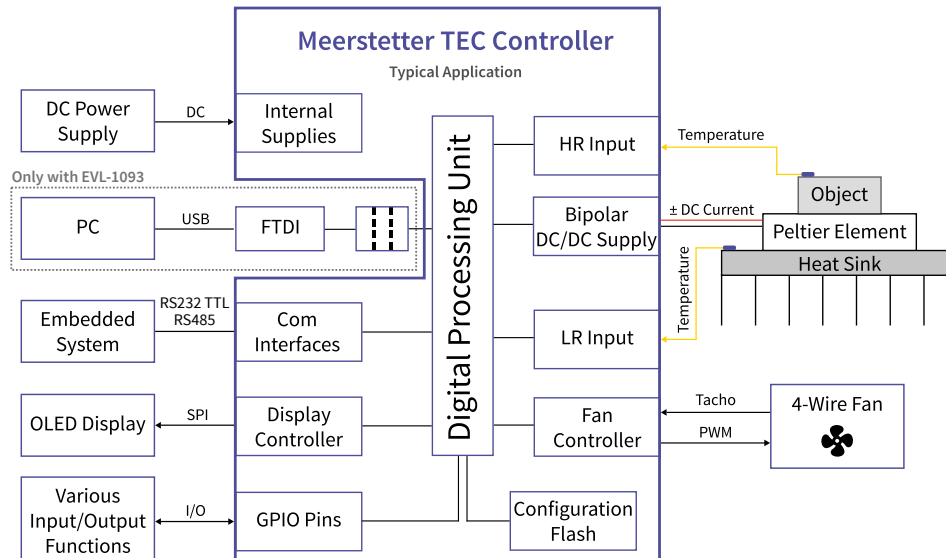

A bipolar DC/DC converter supplies power the Peltier element in unipolar directions. This enables both heating and cooling of the object. A 23-bit high-resolution (HR) measurement input continuously measures the object temperature. Using the acquired temperature, the object temperature is controlled and held stable (deviation is typically 0.01 °C or less) by adjusting the heat pumping capacity.

Waste heat from the object is pumped to a heat sink and further radiated into the environment. A low-resolution (LR) input monitors the temperature of the heat sink to further optimize the control algorithm (not required but recommended). Optional fans enable controlling the sink temperature through forced air removal. The TEC Controller features two separate 4-Wire fan interfaces with integrated fan control.

Once configured, the device operates standalone by storing its configuration parameters in internal non-volatile flash storage. The configuration can be changed by using our [configuration software](#) or [MeComAPI](#) through the isolated USB port (when using the EVL-1093 development adapter) or RS-interfaces.

Please ensure that the device supports your required communication interface and refer to the [Remote Control Guide](#) for more detailed information.

For easy on-site status information, an OLED display can be connected to show any parameter by freely setting it up through software.

The controller supports various GPIO functionalities for monitoring and controlling of the device. Features include Driver Enable, Error Indication, Fan Control & Pump Enable, Temperature Stable Indication, Temperature Increment/Decrement and more. Most functions can be freely assigned to any GPIO.

i For more information on the operation of the device and the Peltier elements, as well as how to dimension them, please refer to the [compendium](#) on our website.

3.2 Operation Modes and Communication Options

The TEC-1092 is an OEM precision TEC Controller that is primarily designed as a PCB mountable device. However, the TEC-1092 can be mounted on the EVL-1093 Evaluation Board. This allows the connection to a host by USB and usage of a DPY-111x TEC Status Display Kit.

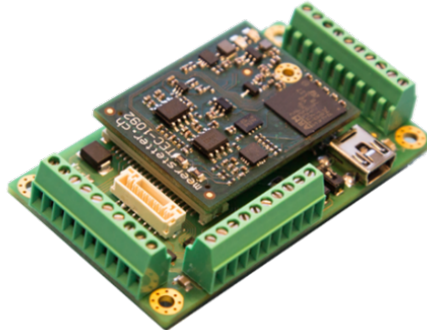

Status information can be polled at any time by industry standard RS485 / RS232 TTL connection or by USB. The TEC-1092 can also operate in a remote-controlled manner, with parameters adjusted on the fly. Scripting capability by sequential lookup table read-out is supported.

Configured as a DC power-supply, the TEC-1092 can handle current and voltage settings. In the remote-control case, temperature data may be passed on to be processed by the host.

Configurable parameters further include: sensor linearization (Pt100 / Pt1000) and Steinhart-Hart modeling (NTC), temperature acquisition hardware calibration, Peltier element modeling, PID controller auto tuning, nominal temperature ramping, current, voltage and temperature limits, error thresholds, etc. Please refer to the TEC Controller User Manual (Document 5216) for further information.

3.3 Hardware Configuration

High Resolution Sensor Type:

NTC: By default, we mount an NTC1M. If you require an older version (NTC18K, NTC39K or NTC56K), please write which one you need in the comment section of your order or contact us: contact@meerstetter.ch.

Thermocouple:

To use our TEC Controllers with thermocouples type K, you need a TCI-1181 in addition to the TEC Controller with a VIN1 High Resolution Sensor Type configuration.

Customization:

Many hardware and software features of the TEC-1092 are customizable upon request. Please contact Meerstetter Engineering with your enquiry.

4 INTERFACE AND CONNECTORS

4.1 RS232 TTL and General Purpose Digital I/O Characteristics (GPIO1 ... GPIO8, RX, TX)

Unless otherwise noted: $T_A = 25^\circ\text{C}$, $U_{IN} = 12\text{ V}$

Symbol	Parameter	Test Conditions / Hints	Min	Typ	Max	Units
Input Characteristics:						
U_{IH}	Logic high input threshold		2.38			V
U_{IL}	Logic low input threshold				0.93	V
U_{IMAX}	Maximum input voltage	General Purpose Inputs are 5V-tolerant	-0.5		5.5	V
Output Characteristics: (Microprocessor)						
U_{OH}	Logic high output voltage	Output current 8 mA	2.8	3.3	3.4	V
U_{OL}	Logic low output voltage	Input current 8 mA			0.4	V

4.2 Package Outline and Pin Configuration

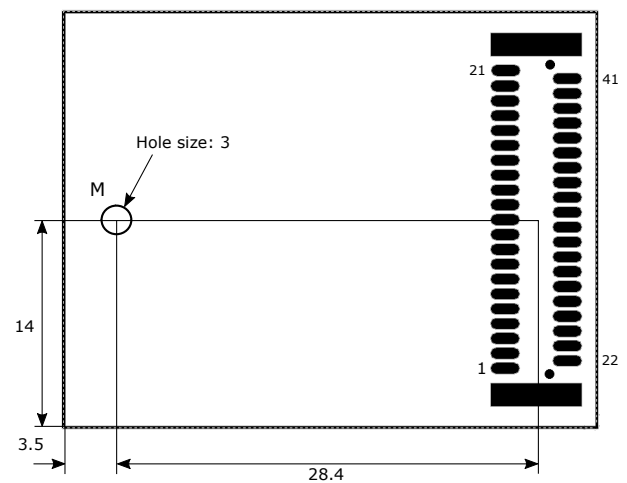
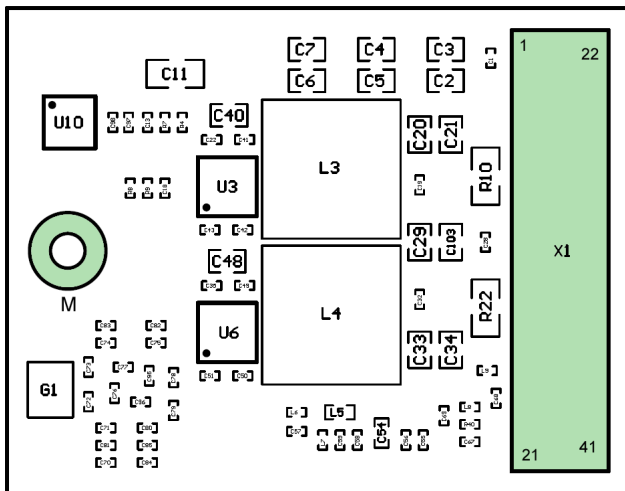

- For direct PCB mounting: The PCB should be mounted at the mounting bore M using an M2 screw Receptacle height when mated: 5.00 mm
- X1 connector type: Amphenol FCI, 41 Position Connector Receptacle, manufacturer P/N 91930-21141LF, Digi-Key P/N 609-1594-ND
- Mating connector type: Amphenol FCI, 41 Position Connector Header, manufacturer P/N 91911-31341LF, Digi-Key P/N 609-3427-1-ND
- PCB SMD threaded standoff (for bore hole M on host PCB): Würth Electronics, M2, manufacturer P/N 9774050243R, Digi-Key P/N 732-7097-1

4.3 Pin Description X1

1	VDD	OUT+	8
2	VDD	OUT+	9
3	VDD	OUT+	10
4	GND	OUT-	11
5	GND	OUT-	12
6	GND	OUT-	13
7	GND		
		SHILED	14
		OBJECT_IA	15
21	RS232_RX	OBJECT_IB	16
22	RS232_TX	OBJECT_UA	17
		OBJECT_UB	18
23	RS485_A		
24	RS485_B	SINK_B	19
		SINK_A	20
25	GPIO1		
26	GPIO2	NJTRST	36
27	GPIO3	JTDO	35
28	GPIO4	JTCK	38
29	GPIO5	JTMS	39
30	GPIO6	JTDI	37
31	GPIO7		
32	GPIO8	NRST	40
33	3.3V	NC	41
34	5V	MOUNTING	M

- Pin 35–40: JTAG programming signals (do not connect) or may be used for DPY-111x displays.
- Pin 33 (3.3 V) outputs up to 200 mA for external loads
- Pin 34 (5 V) outputs up to 100 mA for external loads

4.4 Temperature Sensor Connection X1

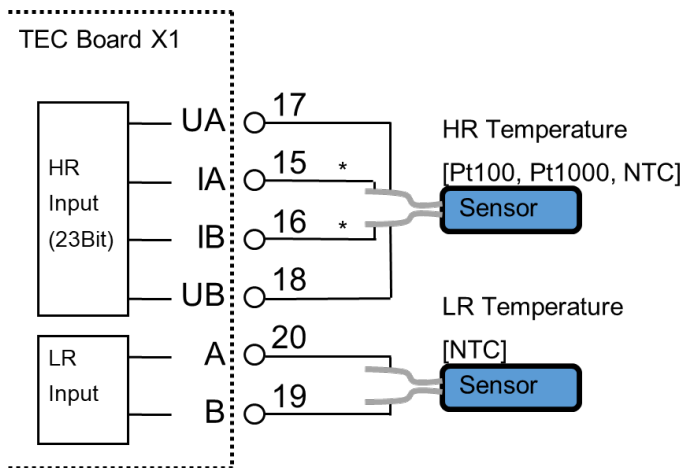

* The TEC-1092 always uses 4 wires to sense the High Resolution temperature. There are no bridge jumpers on board. For NTC, please make a bridge on the mother board close by the X1 connector.

5 ORDERING AND CONFIGURATION

5.1 TEC-1092 Ordering Information & Configuration

Example Configuration:

TEC-1092 (NTC) FW6.31

Variant Name	Requirement	Description	Options / Single choice
High Resolution Sensor Type ¹	Required	Select the temperature sensor type for the HR input.	PT100, PT1000, NTC, VIN1
Firmware Version	Optional	Select a compatible firmware if you do not want the latest version (default). Check the relevant Software Release Notes for details.	Example: FW6.31
Customer Specific Modifications	Advanced	Usually hardware modifications, available only on demand and quote.	Empty, or example: CS3
Customer Specific Profile	Advanced	Preset parameters/configuration, available only on demand and quote.	Empty, or example: 15
Hardware Version	-	For reference, specifies the hardware version (latest by default, subject to future change).	Example: HW1.10

¹ See also Chapter 3.3: Hardware Configuration

5.2 Ordering Confirmation Example

TEC-1092 (NTC, HW1.10)

Firmware Version: FW6.31

String can additionally contain:

Profile: Default

6 ALL MEERSTETTER ENGINEERING PRODUCTS

6.1 Meerstetter Engineering's Product Compatibility

The Laser Diode Drivers and TEC Controllers from Meerstetter have been developed to work along with each other. They share the same platform bus, communication protocol and hardware architecture. See the following table for an overview of the Laser Diode Drivers and TEC Controllers from Meerstetter Engineering:

Model	Output	Description	
Laser Diode Drivers			
LDD-1321	0–1.5 A / 0–14 V	CW, Add-on TEC Controller available	
LDD-1301	0–20 A / 0.5–45 V	1 ms – CW	
LDD-1303	0–20 A / 1–120 V	1 ms – CW	
LDD-1137	0–75 A / 0–70 V	1 ms – CW	
LDD-1124	0–1.5 A / 0–15 V	CW, modulated modes	
LDD-1121	0–15 A / 0–15 V	1 μ s – CW, modulated, QCW and pulsed modes	
LDD-1125	0–30 A / 0–27 V	1 μ s – CW, modulated, QCW and pulsed modes	
TEC Controllers			
Single-Channel Models	TEC-1092	± 1.2 A / ± 9.6 V	Micro
	TEC-1091	± 4 A / ± 21 V	Small
	TEC-1089	± 10 A / ± 21 V	Medium
	TEC-1162	± 5 A / ± 56 V	Medium-high
	TEC-1090	± 16 A / ± 30 V	Large
	TEC-1163	± 25 A / ± 56 V	Extra-large
Dual-Channel Models	TEC-1161-4A	2 x (± 4 A / ± 21 V)	Small
	TEC-1161-10A	2 x (± 10 A / ± 21 V)	Medium
	TEC-1122	2 x (± 10 A / ± 21 V)	Medium
	TEC-1166	2 x (± 5 A / ± 56 V)	Medium-high
	TEC-1123	2 x (± 16 A / ± 30 V)	Large
	TEC-1167	2 x (± 25 A / ± 56 V)	Extra-large

7 CHANGE HISTORY

Date of change	Version	Changed / Approved	HW Version
October 14, 2024	J	XF / ML	v1.00
Change / Reason <ul style="list-style-type: none"> • Add: Change History • Add: New Main Feature: Measurement Inputs are freely assignable to any Output Channel • Add: New Main Feature: Bipolar output channels can be split into unipolar channels • Add: “Unipolar current per channel” and “Unipolar voltage per channel” specifications in “Electrical Characteristics” section • Add: Max Input Current (I_{IN}) specification in Electrical Characteristics section • Add: Top view image of the TEC-1092 • Mod: Specified that the RS485 Data Interface only supports Half-Duplex communication • Del: “TEC Service Software” section removed 			
April 20, 2026	K	NJ / HS/SR	v1.00
Change / Reason <ul style="list-style-type: none"> • Mod: Datasheet design • Del: Old Ordering codes • Add: Standardized product designations and ordering codes tables • Add: Typical Application Chapter • Add: Typ/Max output voltage (U_{OH}) for GPO pins 			

MEERSTETTER ENGINEERING GMBH

Schulhausgasse 12
3113 Rubigen, Switzerland

+41 31 529 21 00

contact@meerstetter.ch

<https://www.meerstetter.ch/>

Meerstetter Engineering GmbH (ME) reserves the right to make changes without further notice to the product described herein. Information furnished by ME is believed to be accurate and reliable. However typical parameters can vary depending on the application and actual performance may vary over time. All operating parameters must be validated by the customer under actual application conditions.