

OEM Two-Channel TEC Controller

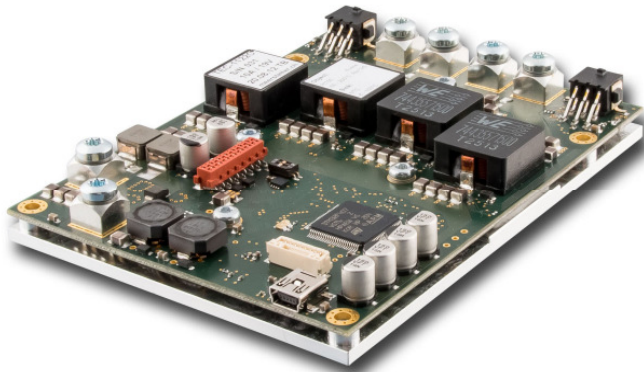

Features

DC Input Voltage:	12 – 24 V nominal
TEC Controller / Driver:	Two Independent Channels
Output Current *:	0 to ± 16 A, <1.5% Ripple (0 to ± 10 A available as TEC-1122)
Output Voltage *:	0 to ± 19 V (max. $V_{IN} - 3.5$ V)
Temp. Sensor Types *:	Pt100, Pt1000, NTC
Temperature Precision:	<0.01 °C
Temperature Stability:	<0.01 °C
Thermal Power Control *:	PID, Performance-optimized
Configuration / Diagnosis *:	via USB / RS485 (Software)
Dimensions (L x W x H):	120 mm x 90 mm x 18 mm
Efficiency:	>93% (@ >50% Load)
Cooling:	over Base Plate

* per Channel

Advanced Operation

Operation Modes:	
- Stand-Alone *	w/o Live Control Interface
- Remotely-Controlled *	USB; RS485; RS422; I/O
- Script-Controlled	Lookup Table Read-Out
Driver Modes:	
- DC Power Supply *	Current / Voltage Settings
- Temperature Control *	PID Settings, Auto Tuning
- Heat Only / Cool Only *	only Pos. or Neg. Currents
- Parallel	for up to ± 32 A / ± 19 V (Doubled Output Current)
Control Interfaces:	Isolated USB 2.0, 2x RS485 / RS422 8x Digital I/O (3.3 V / 5 V, General Purpose)
Aux. Temp. Sensor Type *:	NTC (on Heat Sink Peltier)
	* per Channel

Further Information

Please contact us for additional information, or consult the current TEC Controller User Manual (Document 5134).

General Description

The TEC-1123 is a specialized TEC controller / power supply able to precision-drive two independent Peltier elements.

Each channel features a true bipolar current source for cooling / heating, two temperature monitoring inputs (1x main, 1x auxiliary) and intelligent PID control with auto tuning. The TEC-1123 is fully digitally controlled, its hard- and firmware offer various communication and safety options.

The included PC-Software allows configuration, control, monitoring and live diagnosis of the TEC controller via USB and RS485. All parameters are saved to non-volatile memory.

For the most straightforward applications, only a power supply, Peltier elements and two temperature sensors need to be connected to the TEC-1123. After power-up the unit will operate according to pre-configured values. (In stand-alone mode no control interface is needed.)

The TEC-1123 can handle Pt100, Pt1000 or NTC temperature probes. For highest precision and stability applications a Pt1000 / 4-wire input configuration is recommended. (Temperature acquisition circuitry of each individual device is factory-calibrated to ensure optimal accuracy and repeatability.)

Auxiliary temperature inputs allow the connection of NTC probes that are located on the heat sinks of the Peltier elements. This additional data is used to compensate for parasitic thermal conduction of Peltier elements.

The heating and cooling power is optimized by proprietary thermal management routines based on power balance models (for Peltier elements and resistive heaters).

The TEC-1123's two independent channels may also be operated in parallel ('master / slave'), to either drive two individual or one common load (current doubling).

Further functionality includes: Smooth temperature ramping, thermal stability indication and auto gain (NTC probes). The PC-Software allows data logging and configuration import/export.

Many features (hardware, software) of this OEM product are customizable upon request.

The TEC-1123 is part of the TEC-Family of Meerstetter TEC controllers. It is designed to operate alongside devices of the LDD-Family of laser diode drivers. Both families of drivers share the same system bus, design, technology and physical dimensions.

Applications

Optics (Laser Diodes, Crystals, ...)

Electronics (Detectors, RF References, ...)

Instrumentation (Microscopy, Materials, Biochemistry, ...)

Absolute Maximum Ratings	
Supply voltage (DC)	27 V
Supply current (DC)	32 A
Bipolar output voltage	±26.5 V
Bipolar output current	±22 A (per channel)

Operating Ratings	
System base plate	< 50 °C
Operation temperature	0 – 60 °C
Storage	-30 – 70 °C
Humidity	5 – 95%, non-condensing

Electrical Characteristics

Unless otherwise noted: $T_A = 25\text{ °C}$, $V_{IN} = 24\text{ V}$, $R_{load} = 0.85\ \Omega$

Symbol	Parameter	Test Conditions	Min	Typ	Max	Units
DC Power Supply Input:						
V_{IN}	Supply voltage		11.5	24	26.5	V
V_{IN} Ripple	Ripple tolerance				300	mV _{PP}
Output (per Channel):						
I_{OUT}	Bipolar current swing				±16	A
V_{OUT}	Bipolar voltage swing	V_{IN} at least 3.5 V greater than V_{OUT}			±19	V
V_{OUT} Ripple	Voltage ripple	$R_{load} = 1.13\ \Omega$, 16 A		145		mV _{PP}
System Characteristics:						
$\eta_{50\%}$	Power efficiency	@ 50% load		94		%
$\eta_{90\%}$	Power efficiency	@ 90% load		95		%
Output Monitoring:						
I_{OUT} Read	Precision	@ 0 A, 8.0 A, 16.0 A		200		mA
V_{OUT} Read	Precision	@ 0 V, 7.5 V, 15.0 V		50		mV

Object Temperature Monitoring Characteristics (Pt100 and Pt1000 Probes)

$T_A = 25\text{ °C}$, measurement configuration = 23bit / 4-wire / unshielded cable <50mm, °T probe = Pt100

Symbol	Parameter	Test Conditions	Min	Typ	Max	Units
Temperature Monitoring Ranges:						
T_{OBJ}	°T on object side	Pt100	-50		+200	°C
			extendable upon request			
		Pt1000	-50		+200	°C
			extendable upon request			
Temperature Monitoring Precision:						
T_{OBJ}	°T on object side	Reference measurement fluctuations while output stage operating @70% load		0.002	0.01	°C
Long-term Temperature Monitoring Repeatability:						
T_{OBJ}	°T on object side	Repeated measurements of reference resistors after up to 3 days		0.005		°C

Object Temperature Monitoring Configurations (NTC Probes)

NTC thermistor resistive input characteristics translate into temperature ranges valid for only one type of NTC probe. Below example is given in the case of an NTC B_{25/100} 3988K R₂₅ 10k temperature sensor.

Symbol	Parameter	Test Conditions	Min	Typ	Max	Units
Thermistor Input and Temperature Monitoring Ranges:						
$R_{NTC, calibrated}$	Calibrated resistance range (PGA = 1)	High- °T Configuration ($R_s=18k\Omega$) Corresponding temperature range	1080		17910	Ω °C
			84.7 to 12.2			
		Mid- °T Configuration ($R_s=39k\Omega$) Corresponding temperature range	2340		38805	Ω °C
			61.7 to -3.4			
		Low- °T Configuration ($R_s=56k\Omega$) Corresponding temperature range	3360		55720	Ω °C
			51.8 to -10.1			
$R_{NTC, extended}$	Extended resistance range. Auto Gain (PGA = 1 or 8)	High- °T Configuration ($R_s=18k\Omega$) Corresponding temperature range	135		17910	Ω °C
			164.0 to 12.2			
		Mid- °T Configuration ($R_s=39k\Omega$) Corresponding temperature range	293		38805	Ω °C
			130.9 to -3.4			

Sink Temperature Monitoring Characteristics (NTC only)

$T_A = 25^\circ\text{C}$, measurement configuration = 12bit / 2-wire / unshielded cable <50mm, $^\circ\text{T}$ probe = NTC B_{25/100} 3988K R₂₅ 10k

Symbol	Parameter	Test Conditions	Min	Typ	Max	Units
Sink Temperature Monitoring Range:						
T_{SINK}	$^\circ\text{T}$ on heat sink side	NTC B _{25/100} 3988K	-6		+150	$^\circ\text{C}$
Sink Temperature Monitoring Precision:						
T_{SINK}	$^\circ\text{T}$ on heat sink side	Reference measurement fluctuations while output stage operating @70% load		0.05	0.1	$^\circ\text{C}$
Long-term Sink Temperature Monitoring Repeatability:						
T_{SINK}	$^\circ\text{T}$ on heat sink side	Repeated measurements of reference resistors after up to 3 days		0.1		$^\circ\text{C}$

Safety Characteristics

Unless otherwise noted: $T_A = 25^\circ\text{C}$, $V_{\text{IN}} = 24\text{ V}$

Symbol	Parameter	Test Conditions	Min	Typ	Max	Units
Input Transient Overvoltage and Reverse Polarity Protection:						
V_{IN} Trans.	Transients				28.2	V
V_{IN} Pol.	Reverse polarity				-0.7	V
					available option: -28.2 max.	V
Output Stage Protection Delays:						
t_{OFF} Short circuit		Full load condition		10	30	μs
t_{OFF} Power system limits		Current and voltage limits			200	μs
t_{OFF} System failure		System status or temperature faults		100		ms
t_{IMMUN} Immunity to transient noise		Duration of noise on temperature monitors	300			ms
Output Stage Current Supervision: (If the OUT+ and OUT- currents differ too much, an error is generated)						
$I_{\text{OUT_DIFF}}$	Error threshold			800		mA

General Purpose Digital I/O Characteristics (RES1 ... RES8)

Unless otherwise noted: $T_A = 25^\circ\text{C}$, $V_{\text{IN}} = 24\text{ V}$

Symbol	Parameter	Comments	Min	Typ	Max	Units
Input Characteristics:						
V_{IH}	Logic high input threshold		2.31			V
V_{IL}	Logic low input threshold				0.99	V
V_{IMAX}	Maximum input voltage		-0.5		5.5	V
Output Characteristics: (Microprocessor)						
V_{OH}	Logic high output voltage	Output current 8mA	2.9	3.3		V
V_{OL}	Logic low output voltage	Input current 8mA		0	0.4	V
ESD Protection: (Between Processor and Connector)						
V_{PP}	ESD discharge	IEC61000-4-2			100	kV
R_A	Series resistance		170	200	230	Ω

Package Outline and Pin Configuration

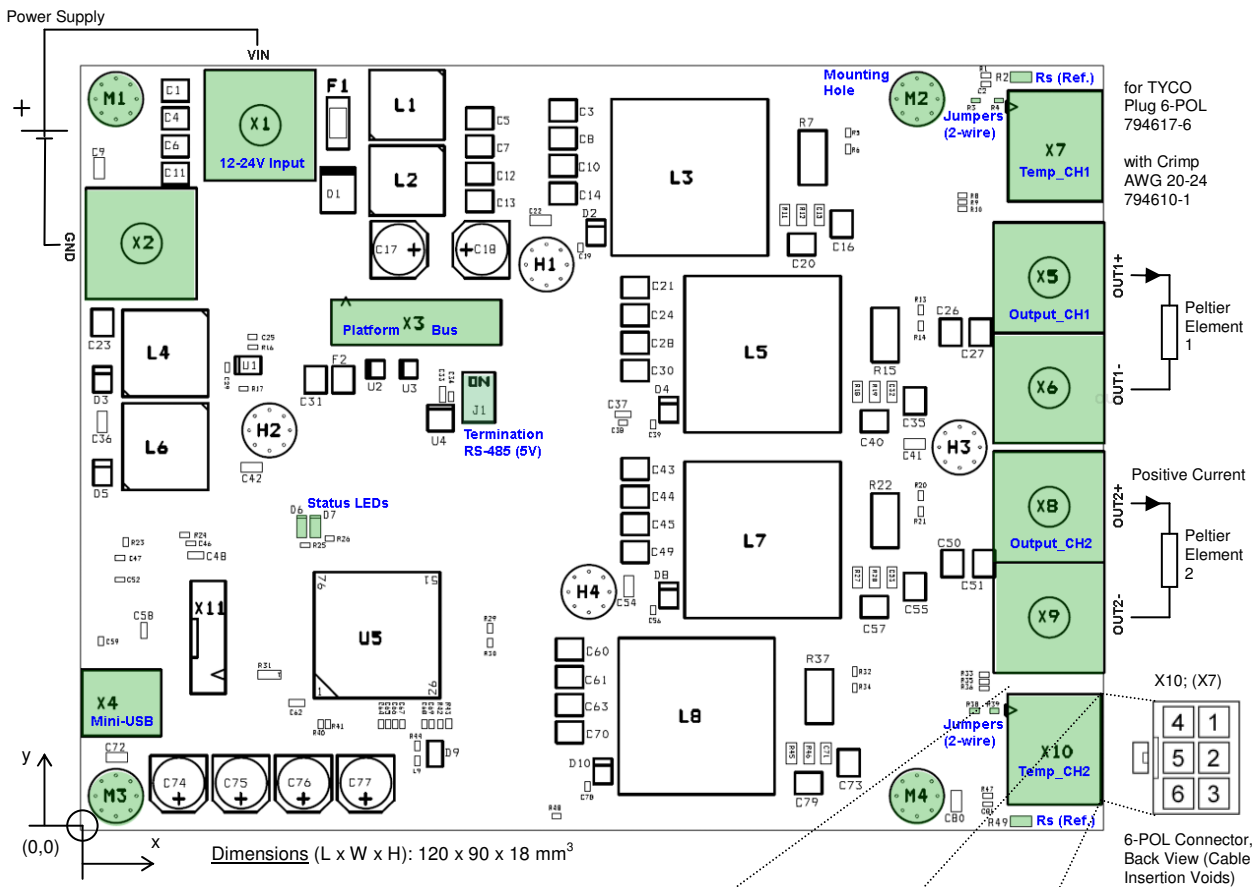

Mounting (M3-size Bores, 7.5 mm in Length):

- M1: x = 4.0 mm, y = 86.0 mm
- M2: x = 98.0 mm, y = 86.0 mm
- M3: x = 4.0 mm, y = 4.0 mm
- M4: x = 98.0 mm, y = 4.0 mm

Power Terminals: M4-size Screws

Pin Descriptions Platform Bus X3:

- 1: GND (fused, PTC) for TYCO Plug 14-POL 8-215083-4
- 2: RES1
- 3: RES2
- 4: RES3
- 5: RES4
- 6: RES5
- 7: RES6
- 8: RES7 [used by LDD-Family devices as PULSE]
- 9: RES8 [used by LDD-Family devices as ENABLE]
- 10: GND (fused, PTC)
- 11: RS485_A1 [120Ω Termination, DIP-Switch J1, 1]
- 12: RS485_B1
- 13: RS485_A2 [120Ω Termination, DIP-Switch J1, 2]
- 14: RS485_B2

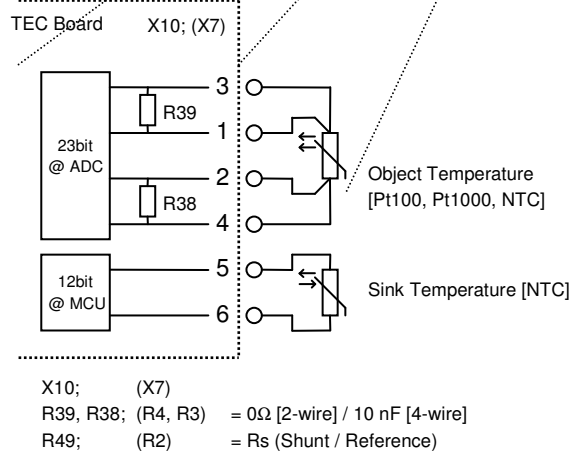

Peltier elements, temperature probes, power supply and connectors not included.

Operation-Modes and Communication Options

The TEC-1123 is an OEM two-channel TEC controller that is primarily designed to operate as a stand-alone device. Its basic operation status is visually indicated by on-board green and red LEDs and their blinking pattern. More detailed status information can be polled at any time by industry-standard RS485 connection or by USB (see box below). The TEC-1123 can also operate in a remotely-controlled manner, with parameters adjusted on the fly. The latest firmware upgrade introduced scripting capability by sequential lookup table read-out.

Configured as a DC power-supply, the TEC-1123 can handle current and voltage settings. In the remote-control case, temperature data may be passed on to be processed by the host. Also, the TEC's two channels can be configured to operate in a 'parallel' mode to double the output current.

Configurable parameters further include: sensor linearization (Pt100 / Pt1000) and Steinhart-Hart modeling (NTC), temperature acquisition hardware calibration, Peltier element modeling, PID controller auto tuning, nominal temperature ramping, current, voltage and temperature limits, error thresholds, etc. Please refer to the TEC Controller User Manual (Document 5134) for further information.

TEC Service Software

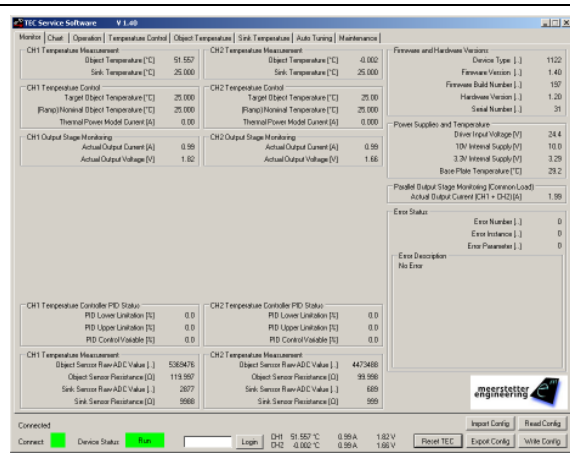

The included TEC Service Software is a powerful tool that allows monitoring, data logging and full configuration of the TEC-1123 via a standard USB or an RS485 connection from a PC running Windows.

This tool is ideal for laboratory setups, product evaluation and commissioning. In conjunction with the comprehensive set of error codes and built-in descriptions, it facilitates diagnosis and debugging.

The software also supplies a user-friendly interface for maintenance (e.g. firmware upgrades), device calibration and basic data logging.

Please refer to the user manual for more information on features and system requirements.

Temperature Control (Autotuned PID)

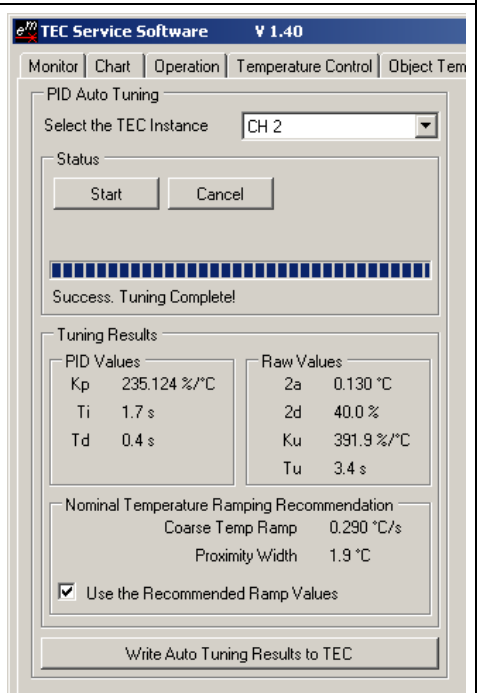
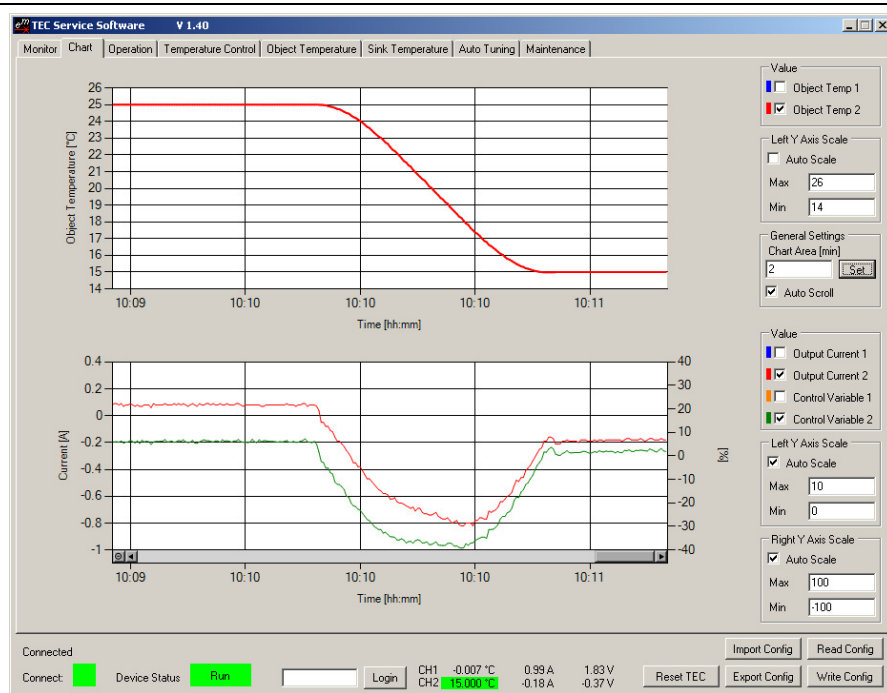

TEC-1123 Ordering Information, Hardware Configuration

Part number*	Object \varnothing T Sensor and Configuration Options	Sink \varnothing T Sensor
TEC-1123	Pt100, 4-wire / Pt1000, 4-wire / NTC, 2-wire ($R_s = 18k\Omega, 39k\Omega$ or $56k\Omega$)	NTC 3988 10k

** Please specify object temperature sensor type when ordering. We recommend the use of Pt1000 sensors. For the case of NTC, $R_s = 39k\Omega$ (Mid- \varnothing T) is standard, $18k\Omega$ (High- \varnothing T) and $56k\Omega$ (Low- \varnothing T) are options.*

Sample Order Numbers:

- TEC-1123-Pt100
- TEC-1123-Pt1000
- TEC-1123-NTC39k

Customization:

Many hardware and software features of the TEC-1123 are customizable upon request. Please contact Meerstetter Engineering with your enquiry.

Meerstetter Engineering GmbH
 Schulhausgasse 12
 3113 Rubigen, Switzerland



Phone: +41 31 712 01 01
 Email: contact@meerstetter.ch
 Website: www.meerstetter.ch

Meerstetter Engineering GmbH (ME) reserves the right to make changes without further notice to the product described herein. Information furnished by ME is believed to be accurate and reliable. However typical parameters can vary depending on the application and actual performance may vary over time. All operating parameters must be validated by the customer under actual application conditions.