

OEM Two-Channel TEC Controller

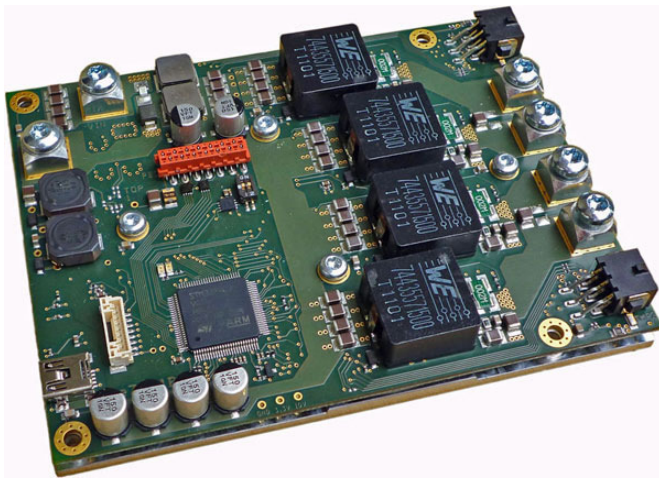

Features

DC Input Voltage:	12 – 24 V nominal
TEC Controller / Driver:	Two Independent Channels
Output Current *:	0 to ± 10 A, <1% Ripple
Output Voltage *:	0 to ± 19 V (max. $V_{IN} - 3.5$ V)
Temp. Sensor Types *:	Pt100, Pt1000, NTC
Temperature Precision:	<0.01 °C
Temperature Stability:	<0.01 °C
Thermal Power Control *:	PID, Performance-optimized
Configuration / Diagnosis *:	via USB / RS485 (Software)
Dimensions (L x W x H):	120 mm x 90 mm x 18 mm
Efficiency:	>90% (@ >50% Load)
Cooling:	over Base Plate

* per Channel

Advanced Operation

Operation Modes:	
- Stand-Alone *	w/o Live Control Interface
- Remotely-Controlled *	USB; RS485; RS422; I/O
- Script-Controlled *	Lookup Table Read-Out
Driver Modes:	
- Power Supply *	Current / Voltage Settings
- Temperature Control *	Temperature / PID Settings
- Heat Only / Cool Only *	only Pos. or Neg. Currents
- Parallel	for up to ± 20 A / ± 19 V (Doubled Output Current)
Control Interfaces:	Isolated USB 2.0, 2x RS485 / RS422 8x Digital I/O (3.3 V / 5 V)
Aux. Temp. Sensor Type *:	NTC (on Heat Sink Peltier)

* per Channel

Further Information

Please contact us for additional information, or consult the current TEC Controller User Manual (Document 5134).

General Description

The TEC-1122 is a specialized TEC controller / power supply able to precision-drive two independent Peltier elements.

Each channel features a true bipolar current source for cooling / heating, two temperature monitoring inputs (1x main, 1x auxiliary) and intelligent PID control with auto tuning. The TEC-1122 is fully digitally controlled, its hard- and firmware offer various communication and safety options.

The included PC-Software allows configuration, control, monitoring and live diagnosis of the TEC controller via USB and RS485. All parameters are saved in non-volatile memory.

For the most straightforward applications, only a power supply, Peltier elements and two temperature sensors need to be connected to the TEC-1122. After power-up the unit will operate according to pre-configured values. (In stand-alone mode no control interface is needed.)

The TEC-1122 can handle Pt100, Pt1000 or NTC temperature probes. For highest precision and stability applications a Pt1000 / 4-wire input configuration is recommended. (Temperature acquisition circuitry of each individual device is factory-calibrated to ensure optimal accuracy and repeatability.)

Auxiliary temperature inputs allow the connection of NTC probes that are located on the heat sinks of the Peltier elements. This additional data is used to compensate for parasitic thermal conduction of Peltier elements.

The heating and cooling power is optimized by proprietary thermal management routines based on power balance models (for Peltier elements and resistive heaters).

The TEC-1122's two channels can operate individually or in parallel ('master/slave') fashion, they function either autonomously (stand-alone) or remotely controlled.

Further functionality includes: smooth temperature ramping, thermal stability indication, auto gain (NTC probes) and residual current detection. The PC-Software allows data logging and configuration import/export.

Some features of this OEM product are readily customizable: Reverse polarity protection, temperature measurement ranges and hardware, digital lines for control, communication protocols, etc.

The TEC-1122 is part of the TEC-Family of Meerstetter TEC controllers. It is designed to operate alongside devices of the LDD-Family of laser diode drivers. Both families of drivers share the same system bus, design, technology and physical dimensions.

Applications

Optics (Laser Diodes, Crystals, ...)

Electronics (Detectors, RF References, ...)

Instrumentation (Microscopy, Materials, Biochemistry, ...)

Absolute Maximum Ratings	
Supply voltage (DC)	26.5 V
Supply current (DC)	20 A
Bipolar output voltage	±19 V
Bipolar output current	±10 A (per channel)

Operating Ratings	
System base plate	< 50°C
Operation temperature	0 – 60°C
Storage	-30 – 70°C
Humidity	5 – 95%, non-condensing

Electrical Characteristics

Unless otherwise noted: $T_A = 25^\circ\text{C}$, $V_{IN} = 24\text{ V}$, $R_{load} = 1.75\ \Omega$

Symbol	Parameter	Test Conditions	Min	Typ	Max	Units
DC Power Supply Input:						
V_{IN}	Supply voltage		11.5	24	26.5	V
V_{IN} Ripple	Ripple tolerance				300	mV _{PP}
Output (per Channel):						
I_{OUT}	Bipolar current swing				±10	A
V_{OUT}	Bipolar voltage swing	V_{IN} at least 3.5 V greater than V_{OUT}		±15	±19	V
V_{OUT} Ripple	Voltage ripple	@ 10 A		90		mV _{PP}
System Characteristics:						
$\eta_{50\%}$	Power efficiency	@ 50% load		91		%
$\eta_{90\%}$	Power efficiency	@ 90% load		93		%
Output Monitoring:						
I_{OUT} Read	Precision	@ 0 A, 5.0 A, 10.0 A		100		mA
V_{OUT} Read	Precision	@ 0 V, 7.5 V, 15.0 V		50		mV

Temperature Monitoring Characteristics

$T_A = 25^\circ\text{C}$, object measurement configuration = 23bit / 4-wire, object $^\circ\text{T}$ probe = Pt100, sink $^\circ\text{T}$ probe = NTC B_{25/100} 3988K R₂₅ 10k

Symbol	Parameter	Test Conditions	Min	Typ	Max	Units
Temperature Monitoring Range (Standard):						
T_{OBJ}	$^\circ\text{T}$ on object side	NTC B _{25/100} 3988K [Higher $^\circ\text{T}$ Config, default]	+13		+150	$^\circ\text{C}$
		NTC B _{25/100} 3988K [Lower $^\circ\text{T}$ Config, upon request]	-9		+110	$^\circ\text{C}$
		Pt100	-50		+200	$^\circ\text{C}$
		Pt1000	-50		+200	$^\circ\text{C}$
T_{SINK}	$^\circ\text{T}$ on heat sink side	NTC B _{25/100} 3988K	-6		+150	$^\circ\text{C}$
Temperature Monitoring Precision:						
T_{OBJ}	$^\circ\text{T}$ on object side	Fluctuation of reference measurement during power-supply operation @70% load		0.001	0.01	$^\circ\text{C}$
T_{SINK}	$^\circ\text{T}$ on heat sink side			0.05	0.1	$^\circ\text{C}$
Long-term Temperature Monitoring Repeatability:						
T_{OBJ}	$^\circ\text{T}$ on object side	Repeated measurements of reference resistors after up to 3 days		0.002		$^\circ\text{C}$
T_{SINK}	$^\circ\text{T}$ on heat sink side			0.1		$^\circ\text{C}$

Safety Characteristics

Unless otherwise noted: $T_A = 25^\circ\text{C}$, $V_{IN} = 24\text{ V}$, $R_{load} = 1.75\ \Omega$

Symbol	Parameter	Test Conditions	Min	Typ	Max	Units
Input Overvoltage Protection:						
V_{IN} Trans.	Transients			27		V
V_{IN} Pol.	Polarity	Fuse	20			A
Protection Delays:						
t_{OFF} Short circuit		Full load condition		10	30	μs
t_{OFF} Power system limits		Current and voltage limits			200	μs
t_{OFF} System failure		System status or temperature faults		100		ms
t_{IMMUN} Immunity to transient noise		Duration of noise on temperature monitors	300			ms

Package Outline and Pin Configuration

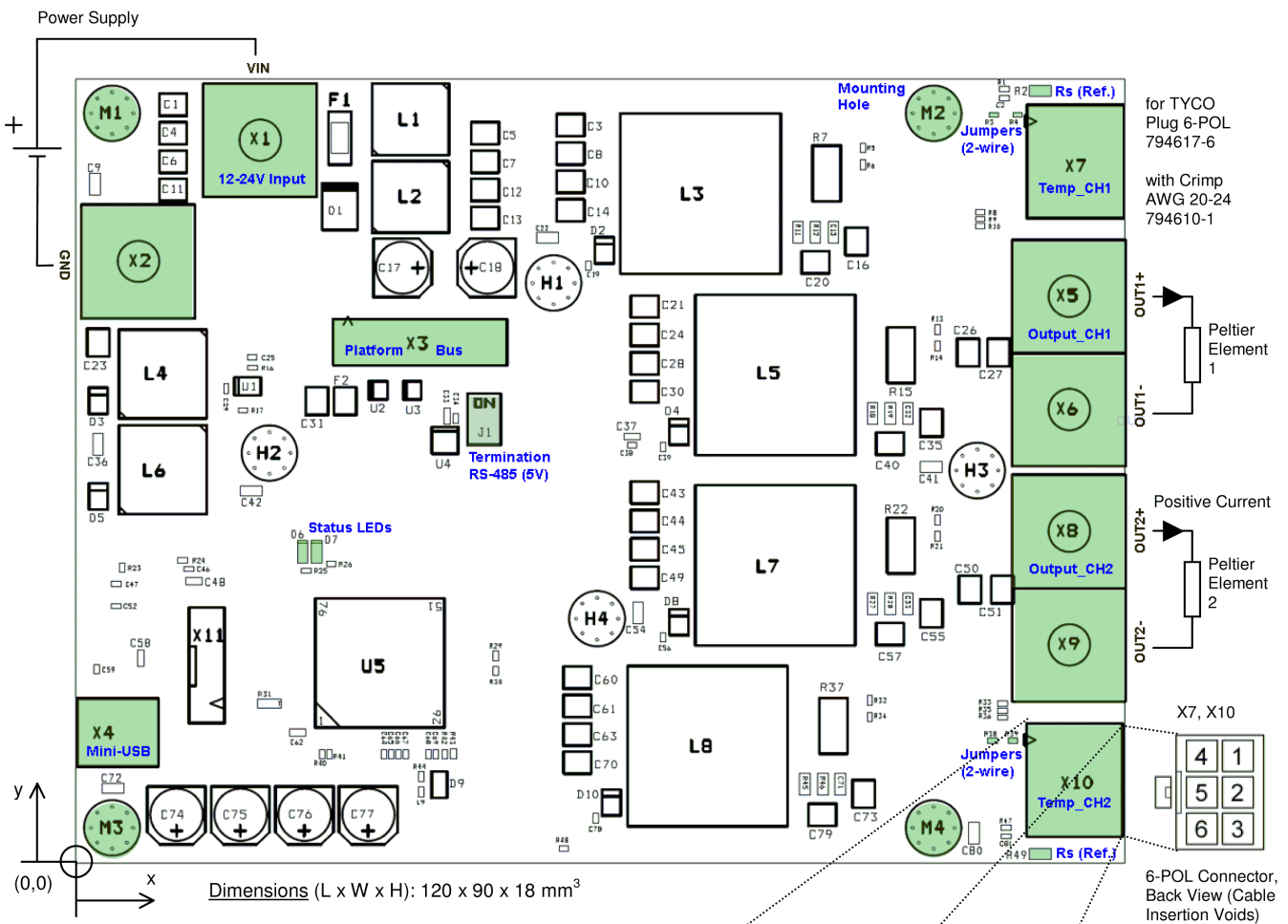

Mounting (M3-size Threads):

- M1: x = 4.0 mm, y = 86.0 mm
- M2: x = 98.0 mm, y = 86.0 mm
- M3: x = 4.0 mm, y = 4.0 mm
- M4: x = 98.0 mm, y = 4.0 mm

Power Terminals: M4-size Screws

Pin Descriptions Platform Bus X3:

- 1: GND (fused, PTC) for TYCO Plug 14-POL 8-215083-4
- 2: RES1
- 3: RES2
- 4: RES3
- 5: RES4
- 6: RES5
- 7: RES6
- 8: PULSE [not used]
- 9: ENABLE [not used]
- 10: GND (fused, PTC)
- 11: RS485_A1 [120Ω Termination, DIP-Switch J1, 1]
- 12: RS485_B1
- 13: RS485_A2 [120Ω Termination, DIP-Switch J1, 2]
- 14: RS485_B2

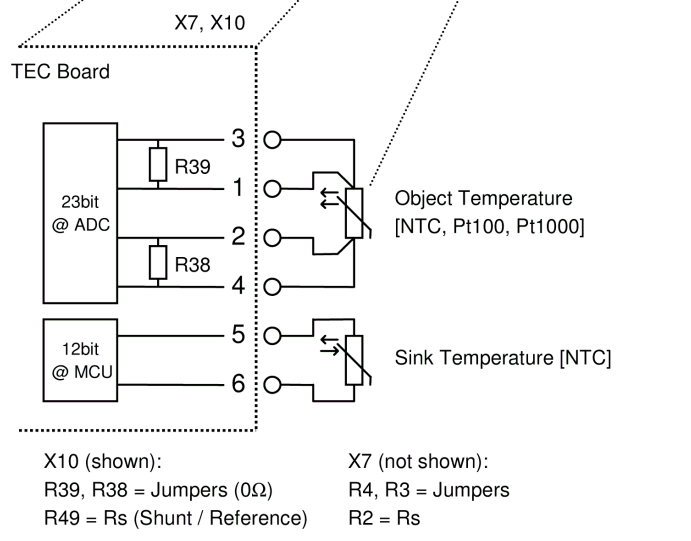

Peltier elements, temperature probes, power supply and connectors not included.

Operation-Modes and Communication Options

The TEC-1122 is an OEM two-channel TEC controller that is primarily designed to operate as a stand-alone device. Its basic operation status is visually indicated by on-board green and red LEDs and their blinking pattern. More detailed status information can be polled at any time by industry-standard RS485 connection or by USB (see box below). The TEC-1122 can also operate in a remotely-controlled manner, with parameters adjusted on the fly. The latest firmware upgrade introduced scripting capability by sequential lookup table read-out.

Configured as a power-supply, the TEC-1122 can handle current and voltage settings. In the remote-control case, temperature data may be passed on to be processed by the host. Also, the TEC's two channels can be configured to operate in a 'parallel' mode to double the output current.

Configurable parameters further include: sensor linearisation (PTC) and Steinhart-Hart modeling (NTC), temperature acquisition hardware calibration, Peltier element modeling, PID controller auto tuning, nominal temperature ramping, current, voltage and temperature limits, error thresholds, residual current detection, etc. Please refer to the TEC Controller User Manual (Document 5134) for further information.

TEC Service Software

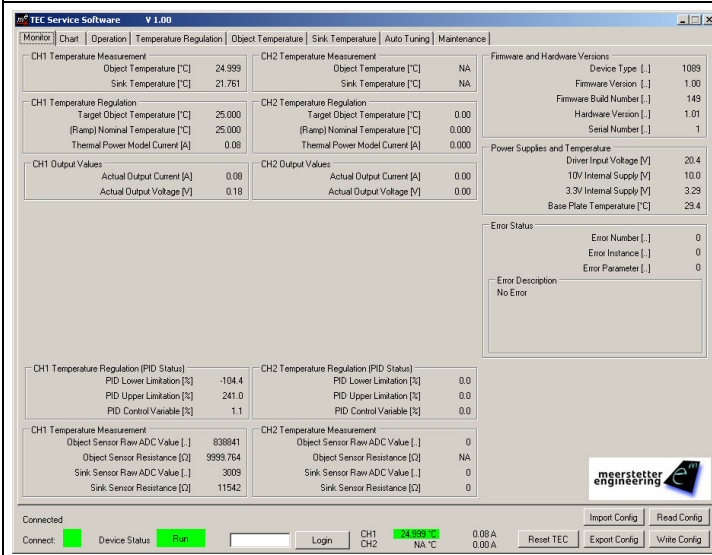

The included service software is a powerful tool that allows monitoring, data logging and full configuration of the TEC-1122 via a standard USB or an RS 485 connection from a PC running Windows. This tool is ideal for laboratory setups, product evaluation and commissioning. In conjunction with the comprehensive set of error codes and built-in descriptions, it facilitates diagnosis and debugging. The software also supplies a user-friendly interface for maintenance (e.g. firmware upgrades), device calibration and basic data logging. Please refer to the user manual for more information on features and system requirements.

(Please note that the present service software is a tool that has been programmed by Meerstetter Engineering for internal use. It is being made available to customers 'as is'.)

TEC-1122 Ordering Information, Hardware Configuration

Part number*	CH1 Object Config.	CH1 Object Sensor	CH1 Sink Sensor	CH2 Object Config.	CH2 Object Sensor	CH2 Sink Sensor
TEC-1122	23bit, 4-wire	Pt100	NTC 3988 10k	23bit, 4-wire	Pt100	NTC 3988 10k
TEC-1122

* Line 1: Example Configuration, Please specify sensor types and configuration when ordering.

CH1 and CH2 object temperature measurement inputs can be hardware-configured either as high resolution 23bit ADC in 2- or 4-wire settings, or as low resolution 12bit MCU budget version.

CH1 and CH2 object temperature sensors [not supplied] can be either Pt100 (HiRes only), Pt1000, or NTC. Please refer to the user manual for pre-set temperature range and default sensor type.

CH1 and CH2 sink temperature measurement inputs (12bit) can cater for NTC sensors, or they can be omitted (budget version). Please indicate temperature range and exact sensor type if different from standard.

Further customization can include optional reverse polarity input protection, digital lines for control, and diagnosis and communication protocol. Please contact Meerstetter Engineering GmbH with your inquiry.

Meerstetter Engineering GmbH
Schulhausgasse 12
3113 Rubigen, Switzerland



Phone: +41 31 712 01 01
Email: contact@meerstetter.ch
Website: www.meerstetter.ch

Meerstetter Engineering GmbH (ME) reserves the right to make changes without further notice to the product described herein. Information furnished by ME is believed to be accurate and reliable. However typical parameters can vary depending on the application and actual performance may vary over time. All operating parameters must be validated by the customer under actual application conditions.