

User Manual – TEC Controller

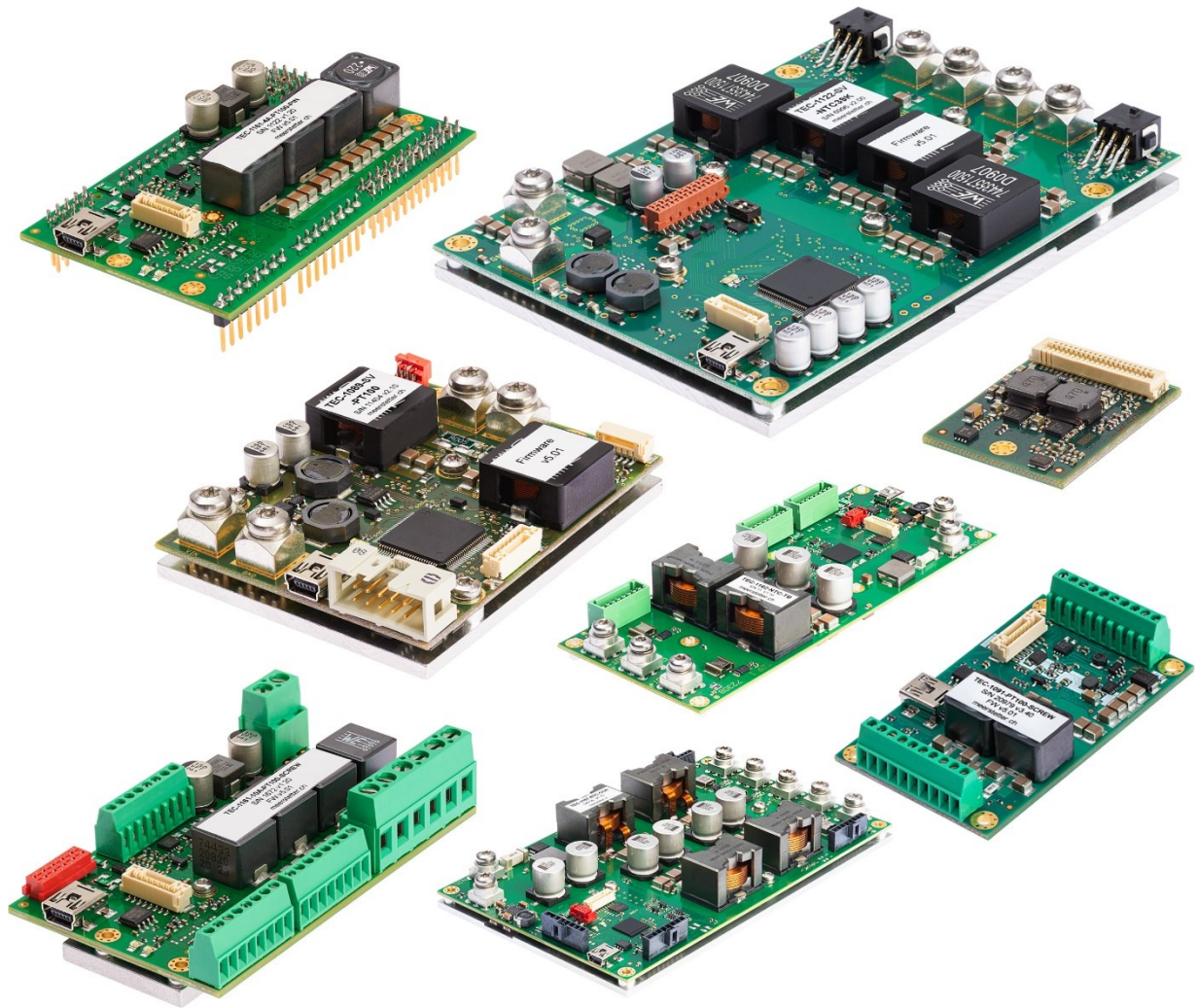

TEC-Family

TEC-1092

TEC-1089

TEC-1122

TEC-1162

TEC-1091

TEC-1090

TEC-1123

TEC-1163

TEC-1161

TEC-1166

TEC-1167

meerstetter
engineering 

 Member of Berndorf Group



Developed, assembled and tested in Switzerland

Index

1	Introduction	4
1.1	Important Documents.....	4
1.2	How to Contact Support	4
1.3	Software Requirements	5
2	Basic Functions.....	6
2.1	The Status Bar of the TEC Configuration Software	6
2.2	Tooltips.....	11
2.3	Remote Control Options	12
2.4	Operating the Power Stage.....	13
2.5	Firmware Updates.....	15
3	Temperature Measurement	17
3.1	High Resolution Measurement (HR Input).....	18
3.2	Low Resolution Measurement (LR Input)	24
3.3	Assignment of Measurement Inputs to Channels	25
4	Temperature Control	27
4.1	Theory of Operation.....	27
4.2	Control Modes	28
4.3	PID Auto Tuning (PID Parameter Optimization).....	29
4.4	Operating Modes & Parallel Operation	32
5	Charting and Data Logging	35
5.1	Charts/Graphs.....	35
5.2	Log.....	39
5.3	Real Time CSV Log	39
6	External Hardware	40
6.1	GPIO1 – GPIO10 Control Signals	40
6.2	Display Kits	47
7	Special Functions.....	51
7.1	Lookup Table Processing & Scripting	51
7.2	Advanced Misc Settings	53
8	Appendix	54
8.1	Troubleshooting.....	54
8.2	Error Numbers, Instances and Parameters.....	55
A	Change History.....	68

Meerstetter Engineering GmbH

Schulhausgasse 12

CH-3113 Rubigen

Switzerland

Phone: +41 31 529 21 00

Email: contact@meerstetter.ch

Meerstetter Engineering GmbH (ME) reserves the right to make changes without further notice to the product described herein. Information furnished by ME is believed to be accurate and reliable. However typical parameters can vary depending on the application and actual performance may vary over time. All operating parameters must be validated by the customer under actual application conditions.

Document 5216J

TEC Controller Firmware Version v6.00

Release date: 23 September 2024

1 Introduction

This manual covers the functionality of the TEC-Family digital temperature controllers. If you use our TEC Controllers the first time, we recommend you watch first our tutorial videos or read the step-by-step guide document available on our website.

Most of the explanations in this document assume, that you use the "TEC Configuration Software", but all the operations can also be done by your own application if you implement the functionality. Most of the commands are documented in our communication protocol documents.

If you cannot find the feature or setting you need, please do not hesitate to contact our support. We do also provide customized firmware solutions.

1.1 Important Documents

- [Datasheets](#)
 - Technical specifications
 - Temperature configurations and possible temperature measurement ranges
 - Ordering information
- [TEC-Family Communications Protocol](#)
 - Protocol specification
 - Commands, Parameters
 - Example Application and [APIs](#)
- [Temperature Sensor Cable Specifications](#)
 - Pinout
 - Temperature sensor assembly
- [Temperature Sensor Suggestions](#)
 - Description, part numbers and distributors for NTC, PT100 and PT1000 sensors
- [Tutorial Videos](#)
 - Learn more about the TEC Controller features and how to set up a cooling system
- [Application Notes](#)
 - Additional Information about different usages of our TEC Controllers

1.2 How to Contact Support

For optimal technical assistance we need the following information:

- Configuration file (if possible exported while the error is present)
 - Click on the "File → Export Config" option in the menu bar of the main window of the Configuration Software.
- Monitor History
 - In the "Log" window, which you can access by clicking on the "Log" button or by clicking on the "Tools → Log" option in the menu bar in the main window, click on the "Export to Excel" button.

Start the [TeamViewer software from our website](#) for a remote-control session. As soon as you start the tool, we will recognize you, but please make sure to call or write us beforehand.

1.3 Software Requirements

The TEC Configuration Software is built on top of .NET 8 by Microsoft. Unlike the older .NET Framework, that the previous TEC Service Software was based on, this runtime is not installed by the Windows operating system by default. Therefore, to be able to run the TEC Configuration Software it is necessary to first download and install the .NET 8 Desktop Runtime. This runtime can be download from the following page on the official Microsoft website: [Download .NET 8.0 \(microsoft.com\)](#). Alternatively, the TEC Configuration Software will display a corresponding dialog when it is launched without the runtime being installed on the machine.

2 Basic Functions

2.1 The Status Bar of the TEC Configuration Software

The bottom row of the software is always visible and shows the following information:

- Left: Connection status
- Middle: Device status (clicking on this control element will perform a Reset of the TEC Controller).
 - Ready: Normal standby status (no errors). Output stage disabled.
 - Run: Normal operating status (no errors). Output stage enabled.
 - Error: Error occurred. Output stage disabled.
 - Bootloader: Firmware is being updated.
- Right: Unsaved parameters status (clicking on this control element will save the unsaved parameters onto the connected device)
 - Transparent: No unsaved parameters present.
 - Orange: Unsaved parameters present.
 - By hovering over this control element in this state, you may see a list of currently unsaved parameter changes.

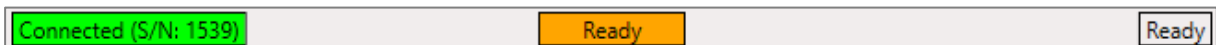

Figure 1: Status bar at the bottom of the TEC Configuration Software.

2.1.1 Status LEDs and Configuration Software Status

TEC-Family devices feature two status LEDs. In normal operation, the green LED is blinking.

In the case of any error occurring, the TEC Controller enters an error status, and the red LED is lit. Power circuitry (output stage) is immediately deactivated for safety reasons. Control, monitoring, and communication circuitry remains active. In case of software / configuration errors (i.e., not hardware faults), parameter can be reconfigured on the fly. The TEC Controller needs to be software-reset or power-cycled to clear the error status.

Table 1: Status LED description

Green LED	Red LED	Signification
Blinking slowly	-	"Ready" status (no errors). TEC output stage disabled.
Blinking fast	-	"Run" status (no errors). TEC output stage is active.
-	Static on	"Error" status. TEC output stage disabled.
Static on	Static on	"FW Update" status.
Blinking	Blinking slowly	Unreleased/Custom firmware is running on the device.

When the TEC Configuration Software is connected to a TEC Controller, the status of the device is displayed in the bottom of the software window:

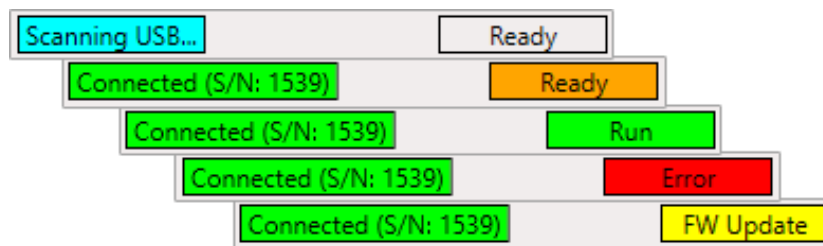

Figure 2: TEC Configuration Software color codes for connection and device status.

Error Condition:

If the TEC Controller enters an error condition, please hover over the red status control element that shows the "Error" text at the bottom of a window. There you can find the error number and description as well as further steps you can take to mitigate the error or reset the device.

Alternatively, you can find a list of all errors here: [8.2 Error Numbers, Instances and Parameters](#).

2.1.2 Reset the TEC Controller

Whenever the TEC Controller enters an error state it is necessary to perform a "Reset" action to clear the error. This can either be done by power cycling the device or by one of the following options within the TEC Configuration Software:

- Click on the "Device Status" control element in the middle of the Status Bar at the bottom of most windows.
- Use the "Device → Reset" option in the main window.

2.1.3 Temperature Stability Indicator

For some applications temperature stability within a temperature range or the time for the stability is important.

When a TEC Controller output stage is operated as temperature controller, the background color of the temperature value in [Figure 1](#) is a visual indicator for stability:

- **Green**, if the temperature is stable

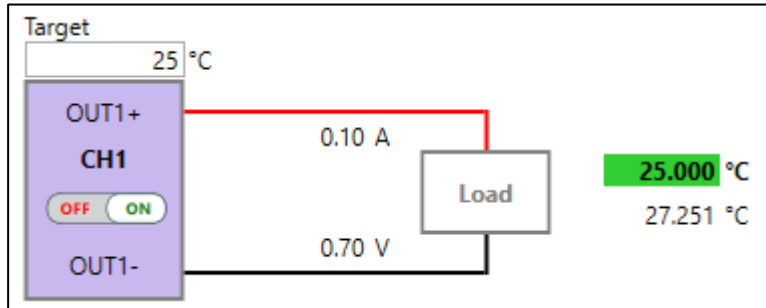

- **Amber**, if the temperature is not within the defined criteria

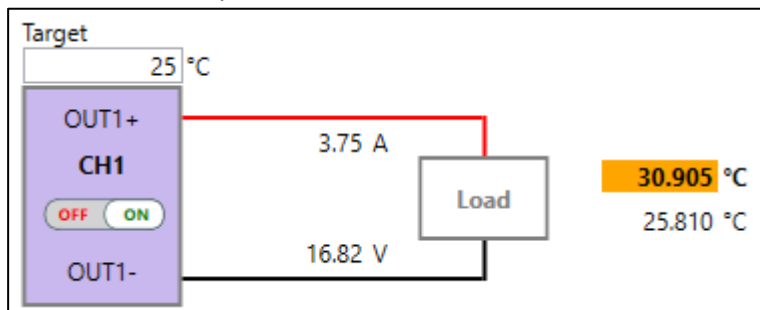

- **Transparent**, if the output stage isn't operated as a temperature controller or if the output stage is off

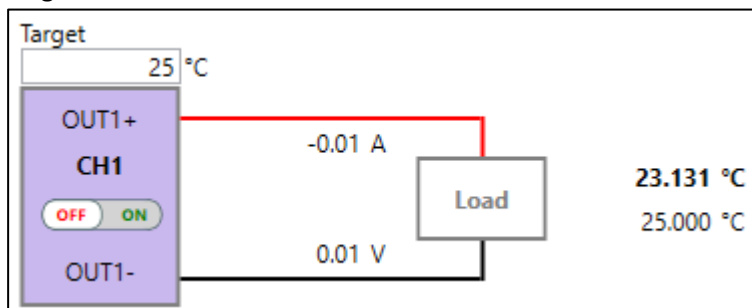

The Temperature Stability Criteria consists of a temperature range and time frame, defined in the "Temperature Controller" window within the "Stability Indicator" box. Stability is given if the temperature is...

- inside the range defined in "Deviation"
- for a certain time (seconds) defined in "Time".

An error is thrown if the object temperature is not stable within the time defined in "Max Time". To disable this feature, set this parameter to 0.

2.1.4 Writing and Reading Device Parameters

When a parameter value is changed an orange circle ("Changed Icon") will appear next to it in the software. When hovering over this circle it will display what the old value was before the change and what the new value will be once written to the device. The old value can be restored before the new value is written to the device by clicking on the circle.

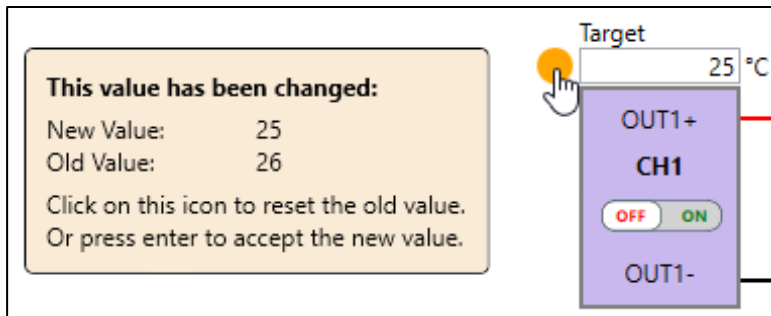

Figure 3: Example tooltip that is displayed when hovering over the orange "Changed Icon" next to a parameter that contains an unsaved change.

Changed parameters are saved to the controller by either clicking on the "Unsaved parameters" field in the status bar of the software, through the "Device → Write Config" option in the menu bar of the main window or by hitting the "Enter" key when the focus is within a parameter control field.

When hovering over the "Unsaved parameters" field in the status bar of the software the parameters that hold unsaved changes are also listed.

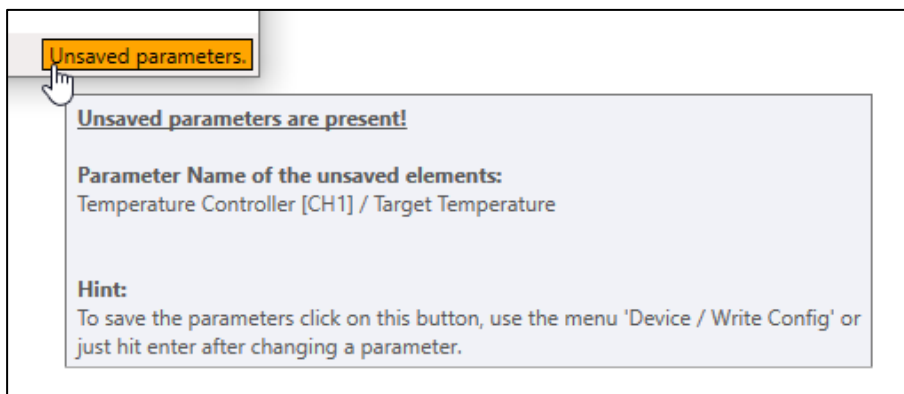

Figure 4: Example tooltip that is displayed when hovering over the "Unsaved parameter" field in the status bar.

Multiple parameter fields can be written at once. Be aware that also fields in windows which are not displayed are written to the controller.

To clear all unsaved parameters without writing them to the device perform a "Reset" or power cycle the device.

Parameters are read automatically when a connection to the controller is established.

2.1.5 Importing and Exporting XML Configuration Files

TEC Controller device configuration sets can be exported as backup, replication onto other devices or for support purposes. They are device-specific as they contain calibration data, but they can still be imported onto other devices without issue as device-specific parameters will simply be skipped during the import process.

- **Export**
 - To save a configuration file on the PC, click on "File → Export XML Config" in the menu bar of the main window of the Configuration Software.
 - All actual values are stored. The values are useful for support and analysis.
- **Import**
 - To load a configuration file from the PC, click on "File → Import XML Config" in the menu bar of the main window of the TEC Configuration Software.
 - Temperature measurement calibration data is only imported when the serial number in the configuration file matches serial number of the connected device.
 - To load a configuration file, that was created using the TEC Service Software, which used another format (.ini) than the TEC Configuration Software, click on "File → Import INI Config". Note: Only the import of configuration files from the TEC Service Software is supported.

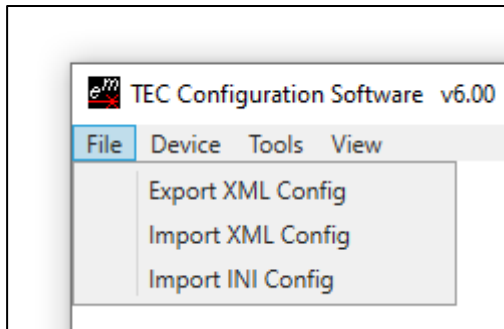

Figure 5: Import and Export Options in the TEC Configuration Software.

2.2 Tooltips

The various input control elements of the TEC Configuration Software, e.g., text input fields, dropdowns, radio buttons, that are used to display and modify parameter values on a TEC Controller provide a variety of information in a tooltip when hovering over them.

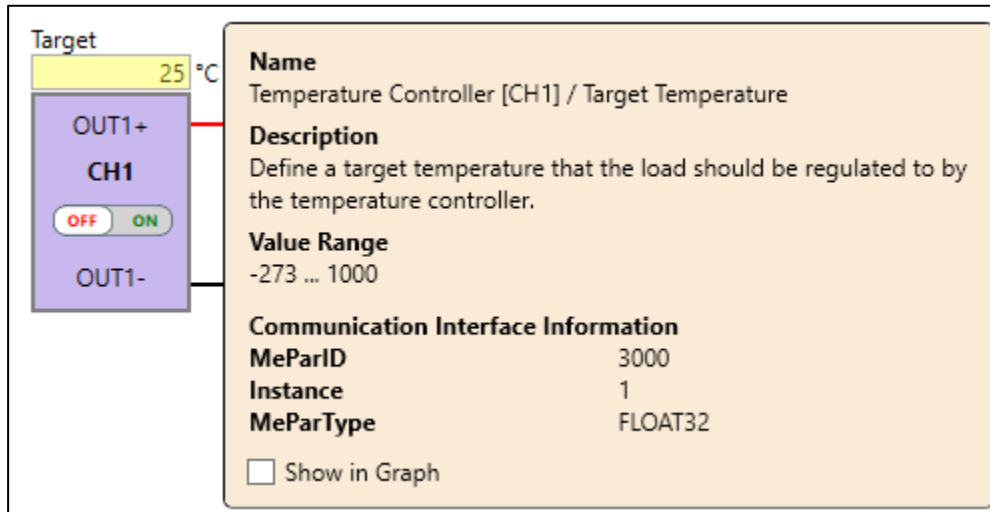

Figure 6: Tooltip of the Target Temperature input field (highlighted in yellow).

The tooltip not only contains the full name and a short description of the parameter, but also "Communication Interface Information", which is supposed to help provide the necessary parameters, when it comes to accessing a parameter for example via one of the various API options that are available.

Keep in mind that some information in the tooltips is only available when the TEC Configuration Software is connected to a TEC Controller.

The tooltips are shown by default, but advanced users that are already familiar with the parameters may optionally disable them by unchecking the option "Enable Mouseover Tooltips" in the "Application Settings" window. This window is accessible via "View > Application Settings" in the menu bar of the main window.

2.3 Remote Control Options

This is an overview of the different remote-control options for the TEC Controllers. It is possible to configure, control and monitor the TEC Controllers using any software which can communicate over an appropriate interface. In the Document "[TEC Controller Communication Protocol 5136](#)" a list of the software options available from us can be found.

Generally, all parameters available in the Configuration Software can be read and written by other means using the communication protocol.

More information is available in the following documents:

- [TEC Controller Communication Protocol 5136](#)
- [TEC LabVIEW Control Software Notes 5200](#)
- [MeComAPI Documentation](#)

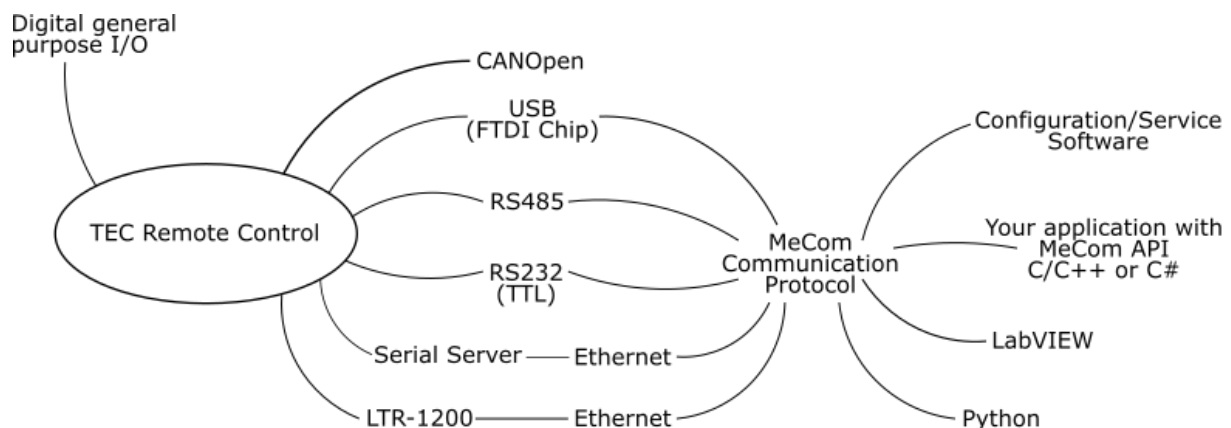

Figure 7: TEC Controller remote control options.

2.3.1 Serial Communication

Serial communication is used to send data from a host to a TEC Controller and receive data from the controller, respectively. The following physical interfaces are supported:

- USB
- RS485 (Further information: [TEC Application Note - RS485 Interface](#))
- RS232 TTL¹

Communication using the Configuration Software and RS485 is only possible using a USB–RS485 adapter or an ethernet serial server, since the Configuration Software only connects to FTDI² chips or TCP port 50000.

¹ Not available on all TEC Controllers

² One option is the [USB RS485 converter cable from FTDI Chip](#), available in different lengths.

2.3.1.1 Addressing Specific TEC Controllers

Assign a unique "Device Address" to the TEC Controller if multiple TEC Controllers are operated on the same platform bus, e.g., when mounted in an LTR-1200 rack enclosure or when the TEC Configuration Software should connect to a specific device. The "Device Address" can be set within the "Communication" window when the TEC Configuration Software is already connected to the device. You can then advise the TEC Configuration Software to use a specific device address to communicate with a device. For this open the "Connection Criteria Manager" window from the "Tools" menu in the menu bar of the main window and look for the "Device Address" input field. For more application arguments, check out the Communication Protocol document.

Note: All TEC Controllers have a 1-unit load receiver input impedance, allowing up to 32 transceivers on the bus.

2.3.2 Ethernet Communication

Communication over Ethernet is possible by integrating up to four TEC Controllers into a [LTR-1200 19-inch rack enclosure](#), which offers an Ethernet connection. This allows the integration into a standard 19-inch rack, or it can be used as table-top instrument.

It is also possible to use a standard Serial Server to connect all our devices to an Ethernet interface. We have tested devices from Lantronix (ex. XPort or UDS1100) and Moxa (ex. NPort 5130). Feel free to contact us if you are looking for application examples.

2.3.3 CANopen

This device supports CANopen according to CiA 301. Please refer to the [TEC Controller Communication Protocol 5136](#) document for further details

2.4 Operating the Power Stage

2.4.1 Theory of Operation

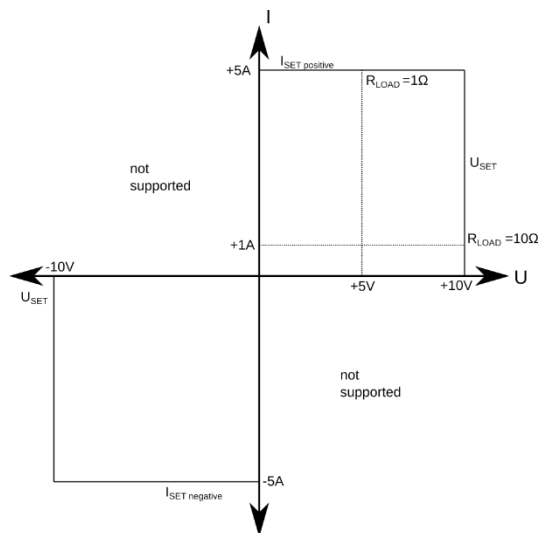

Figure 8: Theory of Operation example sourcing quadrants visualization.

The output stage controller outputs either the desired voltage or the desired current, depending on which value first runs in its limitation. It works in a way like a lab power supply with current and voltage limitation.

The output stage works in the two sourcing quadrants, shown on the left side. The polarity is defined by the I_{SET} value. This means U_{SET} is always entered positive and the I_{SET} can be set positively or negatively.

For this example, the settings are set to:
Output Stage Input Selection: Current/Voltage
Fixed Current: 5 A
Fixed Voltage: 10 V

In one condition a 10 Ohm Resistor is connected. In this case the output stage reaches the 10 V limitation before the 5 A limitation is reached. This means the output stage outputs 10 V at 1 A.

In the other condition, a 1 Ohm Resistor is connected. In this case the output stage reaches first the 5 A limitation. This means the output stage outputs 5 V at 5 A.

2.4.2 Output Stage Controller Settings

The output stage of a channel can be controlled by two sources:

- "Current/Voltage": Values are read from the non-volatile memory (flash).
- "Temperature Controller": The current and voltage values are calculated by the controller as a function of temperature and other information.

The channel's output is activated by the "Output Enable" parameter in the "Temperature Controller" or the main window. "Output Enable" settings are saved to the flash and remain active after a device power cycle or reset.

- In "OFF" mode, the enable status is set to disabled.
- In "ON" mode, the enable status is set to enabled.
- In "HW Enable" mode, the enable status is read from a user defined GPIO. Please refer to chapter [6.1 GPIO1- GPIO10 Control Signals](#) for detailed information.

The "Fixed Output Values" are read when the TEC Controller channel is used as "Current/Voltage":

- The sign of the "Fixed Current" parameter determines the polarity of both the current and voltage.
- "Fixed Voltage" only accepts positive values.

The "Output Stage Limits" are safety settings that limit the TEC Controller's output power to protect the connected Peltier elements or other components.

Refer to the document [TEC-Family Communication Protocol 5136](#) for more information all available parameters.

2.5 Firmware Updates

2.5.1 Standard Update Procedure

You can [download the firmware \(contained in the MSI software package\)](#) from our website and update TEC Controllers using the TEC Configuration Software.

The Configuration Software and the TEC Controller firmware are strongly related. Only when a TEC Configuration Software and a TEC Controller firmware with a matching Version Number are used the full functionality can be guaranteed. However, it is usually possible to connect to an old TEC Controller firmware with a new TEC Configuration Software version and vice versa. Functionality will be limited, but firmware updates are possible.

Matching version numbers: All our publicized software have a version number similar to this: "vX.YZ". It is important that at least X and Y is matching. Z may be different.

Follow these steps to update devices:

- Read the [TEC Software Release Notes](#) document.
- Backup the current configuration. This is important because it is possible that the current configuration will be lost during the update.
- In the main window click on "Device → Firmware Update" in the menu bar.
- Click on "Select *.hex File" and choose the new .hex file.
- Click on "Start Update Firmware" to load the new firmware on the device.
- The TEC Controller will reboot once the update has completed.
- You can check the firmware version in the "System" window.
- Re-import the before exported .xml configuration file (if necessary).
- Fill missing parameter values into new parameter fields (if applicable).
- Check whether all parameter settings still match your expectations. Consult the [TEC Software Release Notes](#) as well as the [TEC Controller Communication Protocol](#) documents to learn what parameters have been changed.

2.5.2 Upgrade Firmware from a Version below 6.00

With the release of firmware v6.00 the default software to configure our devices from a Microsoft Windows operating system was switched from the previous TEC Service Software to the new TEC Configuration Software. This breaking change also means that to upgrade from a firmware version below v6.00 to a version equal to or higher than v6.00 it is necessary to pay attention to a few key points depending on the current firmware version running on the device. Please read the respective conditions in [Table 2](#).

Important notes: Before upgrading your device to firmware v6.00 please read what has been changed in the [TEC Software Release Notes](#) document first, as there were multiple breaking changes introduced with this new version. Furthermore, please export your current configuration (.ini) using the TEC Service Software before the upgrade. Downgrading the firmware from v6.00 to an older version is only possible with the assistance of a Meerstetter Engineering employee!

Table 2: Firmware Upgrade Conditions

Current Firmware Version	Upgrade Conditions
Lower than v5.00	Direct upgrade is not possible, the device needs to be sent back to Meerstetter Engineering for the upgrade. Please contact the manufacturer if you would like to upgrade your device.
Equal to v5.00 or v5.01	First update to firmware v5.10 by downloading the TEC Service Software v5.10 from the download section of our website and update the firmware using the included firmware file (.hex) through the "Device Boot Loader" in the "Maintenance" tab of the TEC Service Software. Afterwards, follow the upgrade steps below to upgrade the firmware from v5.10 to v6.00.
Equal to v5.10	Download the TEC Configuration Software v6.00 from the download section of our website. Upgrade the firmware to v6.00 by following the steps in chapter 2.5.1 Standard Update Procedure.

3 Temperature Measurement

This chapter covers the "HR Input x" and "LR Input x" windows. "HR" stands for "High Resolution", which is often also referred to by "Object Measurement" and "LR" stands for "Low Resolution", which is often also referred to by "Sink Measurement".

Every TEC Controller features multiple temperature sensor measurement inputs used for temperature controlling:

- The HR inputs (23-bit ADC) usually measure temperature of an object.
Supported temperature sensors:
 - PT100
 - PT1000
 - NTC
 - Voltage output sensors
- The LR inputs (12-bit ADC) usually measure temperature of a heatsink and are optionally used.
Supported temperature sensors:
 - NTC

The TEC Controller supports two types of temperature sensors: passive resistance temperature detectors (RTD), also known as thermistors, and voltage output temperature sensors. The passive resistance temperature sensor (RTD) has an accurate resistance per temperature relationship. Hence, to measure the temperature of some object, a sensor is fixed to it and the TEC Controller determines the resistance of the sensor or measures the output voltage, respectively.

3.1 High Resolution Measurement (HR Input)

As a user you define the temperature working range and you choose a sensor type. The supported sensor types for the HR input are the following:

- NTC sensors (negative temperature coefficient, e.g., NTC10k sensors)
- Platinum sensors PT100 or PT1000 (positive temperature coefficient)
- Voltage output sensors

The HR input has an onboard reference resistor R_s which is used by the measurement circuitry. This reference resistor shown in Table 3 is defined as *sensor configuration* within the *hardware configuration* upon ordering and defines the possible temperature measurement range.

Table 3: Default configuration parameters for RTD temperature sensors.

Device Type	Sensor Configuration	R_s (k Ω)	R_p (k Ω)
TEC-1089 TEC-1090 TEC-1122 TEC-1123	PT100	1.5	∞
	PT1000	3.6	∞
	NTC18K	18	∞
	NTC39K	39	∞
	NTC56K	56	∞
	NTC1M	39	39
	NTC	39	39
	VIN1	Diode ³	
TEC-1091 TEC-1092 TEC-1161 TEC-1162 TEC-1163 TEC-1166 TEC-1167	PT100	1.5	∞
	PT1000	3.6	∞
	NTC56K	56	∞
	NTC1M	39	39
	NTC	39	39
	VIN1	Diode ³	∞
	VIN2 ⁴	Shorted	∞

Refer to the TEC Controller datasheets for wiring diagrams for sensors and temperature measurement ranges.

³ In case of voltage output temperature sensors, R_s is a Schottky Diode.

⁴ Not supported on TEC-1092 devices.

3.1.1 NTC Sensors

3.1.1.1 Example NTC Configuration

This example visualizes the relationship between temperature sensor type and sensor configuration.

As an example, we choose a TEC-1091 with an NTC56K sensor *configuration*. As temperature sensor (*type*) we select a NTC B_{25/100}=3988K R₂₅=10k thermistor. The first value describes the temperature-resistance relationship, and the second value indicates that the sensor has a resistance of 10 kΩ at 25 °C.

According to the TEC-1091 datasheet, it's possible to measure a sensor resistance up to 55742 Ω for the NTC56K configuration, which corresponds to a temperature of -10.1 °C. The lowest possible resistance is 105 Ω, which corresponds to 176 °C.

3.1.1.2 Configuration of NTC Sensors

In case of an NTC sensor the temperature to resistance characteristics need to be entered manually by the user.

For each NTC temperature acquisition channel choose three temperatures (lower, middle, and upper) spanning the measurement range to be covered. Look up their corresponding resistances in your sensor's data sheet. Three temperature-resistance pairs are needed to model a characteristic temperature-resistance curve using the Steinhart–Hart equation⁵

$$\frac{1}{T} = A + B \ln(R) + C(\ln(R))^3$$

where T is the temperature (kelvin), R is the resistance (ohms), A, B, and C are the Steinhart–Hart coefficients.

Enter the three value pairs in the "HR Input x" or "LR Input x" window within the field "NTC Sensor Characteristics" of the "Temperature Conversion" box when the "Conversion Type" is set to "NTC".

This curve will be most precise for small ranges (lower point to upper point) that are centered about a working point / nominal temperature (middle point).

3.1.2 PT100 / PT1000 Sensors

PT100 and PT1000 temperature probe characteristics according to DIN EN 60751 are device internally stored and the user does not need to configure anything in the Configuration Software for the temperature measurement.

⁵ [More information about the Steinhart–Hart equation on Wikipedia.](#)

3.1.3 Voltage Output Sensors

The TEC Controller can use a Linear Voltage Output Temperature Sensor to measure the HR input. The characteristics of the sensor must be entered manually by the user.

The values for Reference Temp, Reference Voltage and Temperature Slope are needed, they can be found in the datasheet of the sensor. Enter the three values in the "HR Input x" window within the field "Voltage to Temperature Conversion", which is visible when the "Conversion Type" field is set to "Voltage".

In the Document [TEC Application Note - Voltage Output Temperature Sensors \(-VINx\)](#) Information about how to connect the Sensors to the TEC Controller can be found. The Voltage Measurement Range of each TEC Controller is listed in the corresponding datasheet.

3.1.4 Changing the Measurement Configuration

In case you would like to change the temperature sensor configuration of the HR input (as an example from PT100 to NTC1M), hardware modifications and configuration changes by software are necessary.

The configurations changes can be made by yourself, please [contact us](#), if you don't want to change the configuration by yourself. We recommend that the changes are made by us since we can guarantee a properly performed conversion and we can recalibrate the TEC Controller.

3.1.4.1 Changing between a PT100/PT1000 and a NTC Measurement Configuration

Please follow these instructions:

- Replace the temperature reference resistor R_S ⁶. The requirements for this resistor are: 0.1% tolerance, 5 ppm/°C temp. coefficient, 100 mW power rating, 0805 footprint. In the case of an NTC1M configuration, use a 39 kΩ resistor according to [Table 3](#).
- Only in case of the NTC1M configuration solder the resistor R_P parallel to the sensor input. Use the same resistor type as R_S .
- If the change is from four-wire measurement⁷ (PT100 and PT1000) to two-wire measurement (NTC), then add jumpers to the measurement input. Remove the jumpers if the change is from two wires to four wires. The position is shown in the section *Pin Configuration* of the corresponding datasheet for the TEC Controller. Please note that the TEC-1092 exclusively works with four-wire measurement.
- Perform the following changes in the Configuration Software:
 - Choose the option "NTC" in the "HR Input x" window within the "Hardware depending Default Settings" menu.
 - Click on the "Set Default" button.
 - Persist the settings on the device.
 - Reset the device.

Now you can check the object temperature measurement limits in the "HR Input x" window.

Measurement Limits	
Highest Voltage	NaN V
Lowest Voltage	NaN V
Highest Resistance	1000000 Ω
Lowest Resistance	73 Ω
Temp at max ADC	-55.7 °C
Temp at min ADC	193.5 °C

Figure 9: New temperature measurement limits for NTC configuration of a TEC-1091.

⁶ Refer to the datasheet for the position of R_S . Possible choices for R_S are:

1.5 kΩ: WELWYN PCF0805-13-1K5-B-T1
3.6 kΩ: WELWYN PCF0805-13-3K6-B-T1
18 kΩ: WELWYN PCF0805-13-18K-B-T1
39 kΩ: WELWYN PCF0805-13-39K-B-T1
56 kΩ: WELWYN PCF0805-13-56K-B-T1

⁷ Either two or four wires are used to connect the sensor, depending on the type. See TEC Controller datasheets for wiring. [More information about four-wire measurement on Wikipedia.](#)

3.1.4.2 Changing to a VIN Measurement Configuration

In case a voltage output sensor replaces another sensor type, follow these steps:

- Jumpers at the measurement inputs need to be removed.
- For VIN1 replace R_s by a Schottky diode.⁸
- For VIN2 replace R_s by 0 Ohm resistor and set the 5V jumper to apply 5V to IA.
- Perform the following changes in the Configuration Software:
 - Load the option "VIN1" or "VIN2" in the "HR Input x" window within the "Hardware depending Default Settings" menu.
 - Click on the "Set Default" button.
 - Persist the settings on the device.
 - Reset the device.
- Enter the three values in the window "HR Input x" in the field "Voltage to Temperature Conversion" according to your sensor. This field is visible when the "Conversion Type" field is set to "Voltage".

⁸ A possible choice is Toshiba CUS520,H3F (The voltage drop should be in the range of 0.1V to around 0.3V)

3.1.5 Temperature Measurement Behavior

The behavior of the temperature measurements can be configured in the "HR Input x" and respectively the "LR Input x" windows.

Using the parameters in the "Surveillance" box it is possible to control the temperature measurement conditions that will result in the TEC Controller going into an error state. These are safety measures as the TEC Controller will shut off all outputs when it goes into an error state.

Table 4: Parameter "ADC Limit Errors"

Option	Description
None	Default setting. ADC monitoring is disabled. No errors are generated when limits (→ "Upper Threshold" and "Lower Threshold") are reached.
Upper Only	ADC monitoring is only enabled using the "Upper Threshold".
Lower Only	ADC monitoring is only enabled using the "Lower Threshold".
Both	ADC monitoring is enabled and considers all error thresholds.

Table 5: Parameter "Temp. Limit Errors"

Option	Description
None	Default setting. Temperature monitoring is disabled. No errors are generated when limits (→ "Upper Threshold" and "Lower Threshold") are reached.
Upper Only	Temperature monitoring is only enabled using the "Upper threshold".
Lower Only	Temperature monitoring is only enabled using the "Lower threshold".
Both	Temperature monitoring is enabled and considers all error thresholds.

The sampling frequency specifies the frequency of the measurement cycle. This parameter can be adjusted in the "HR Input x" windows within the "Analog Digital Converter" box. The control speed adapts to the sampling frequency of a HR Input if it is assigned as "Object Source Selection" for a TEC Channel. For all other "Object Source Selection" sources the control speed is always 10Hz.

Table 6: Parameter "Sampling Frequency"

Option	Description
10Hz	Default setting. 10 Hz measurement frequency.
80Hz/90Hz	90 Hz measurement frequency for TEC-1092, TEC-116x and TEC-1091 (hardware version ≥ 3.00) and 80 Hz for other devices.
1Hz	1 Hz measurement frequency.

3.1.6 Analog-to-Digital Converter Self-Check Function

It is possible that a damaged analog-to-digital converter (ADC) delivers incorrect temperature measurement results, which under certain circumstances remain undetected. To resolve this issue an ADC self-check function has been added. This function must be manually activated by the user or can be configured to be periodically executed with a user defined interval. When configured to run periodically, the first measurement is performed 10 seconds after startup. It is not recommended to run the periodic check in time intervals of less than 10 seconds.

While the ADC self-check function is running the temperature measurement results are not updated, so care must be taken to not run the self-test function while critical operating conditions are present or during autotuning. A self-check takes approximately 300ms.

The test function measures the supply voltage of the ADC as well as the current through the reference resistor and the voltage at the voltage reference input. If one of those values is out of range an error is thrown. The current measurement error can be disabled by setting the parameter "Error on IRs fail" to No.

The results of all measurements are stored and can be read for further evaluation.

It is not recommended to use the ADC self-check function when a reference resistor larger than 46k Ω is used as the results might be unreliable. Because of hardware differences, the sensor current cannot be measured when a voltage output sensor is used (-VIN1/2 version). In this case, only the reference voltage is measured and checked.

To start a check the parameter "Trigger Self Check" must be set to 1. After the check has finished, this value is automatically reset to 0. Writing a 0 does not cancel the test. To enable the periodic check the parameter "Periodic Check" must be set to the required period in seconds. If the value is 0 no periodic check is performed.

The ADC self-check function can be configured in the "HR Input x" window.

3.2 Low Resolution Measurement (LR Input)

The Low Resolution Temperature Measurement or LR Input can only accommodate NTC sensors. This input is less configurable and uses on the MCU-integrated 12bit ADC. The circuit's reference resistor R_v is factory-set to 5.6 k Ω .

3.3 Assignment of Measurement Inputs to Channels

The various Measurement Inputs that a TEC Controller offers can be freely assigned to any TEC Channel. This provides a lot of flexibility when it comes to designing a system.

3.3.1 Object Source Selection

The assignment of the "Object Source Selection" for a TEC Channel can be made in the main window of the TEC Configuration Software by clicking on the little configuration buttons that will open a popup:

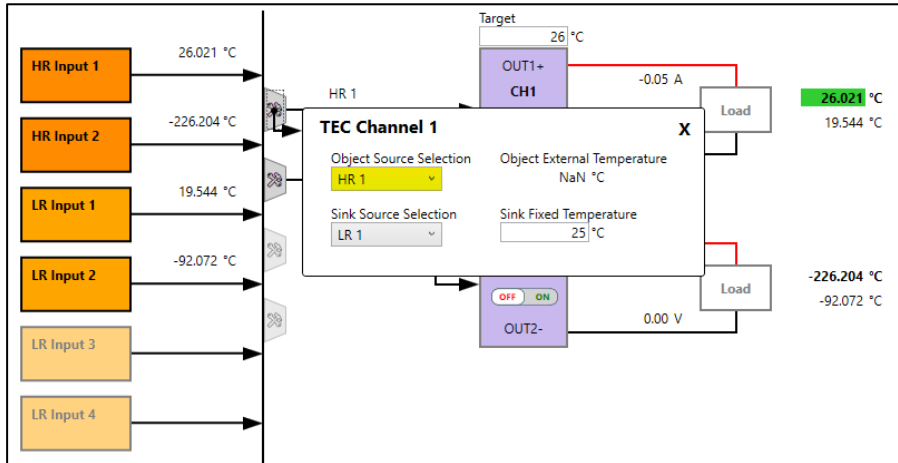

Figure 10: Configuration Popup for TEC Channel 1 in the main window.

Table 7: Parameter "Object Source Selection"

Option	Description
HR 1	The temperature of HR 1 (High Resolution Measurement Circuit 1) is used for temperature controlling.
HR 2	The temperature of HR 2 (High Resolution Measurement Circuit 2) is used for temperature controlling.
LR 1	The temperature of LR 1 (Low Resolution Measurement Circuit 1) is used for temperature controlling.
LR 2	The temperature of LR 2 (Low Resolution Measurement Circuit 2) is used for temperature controlling.
LR 3	The temperature of LR 3 (Low Resolution Measurement Circuit 3) is used for temperature controlling.
LR 4	The temperature of LR 4 (Low Resolution Measurement Circuit 4) is used for temperature controlling.
Device	The Device Temperature of the TEC Controller is being used.
External	The temperature can be fed over a data communication interface. The temperature value needs to be written to the parameter "Object External Temperature" (ID 52200). Keep in mind that it is recommended to write the temperature value to this parameter at least once every 100ms. If it is not written to within a timeout period of 5 seconds, it will automatically reset to 'NaN' (Not a Number), which stops the temperature regulation and leads to no more output current being supplied.

3.3.2 Sink Source Selection

The assignment of the "Sink Source Selection" for a TEC Channel can be made in the main window of the TEC Configuration Software by clicking on the little configuration buttons that will open a popup:

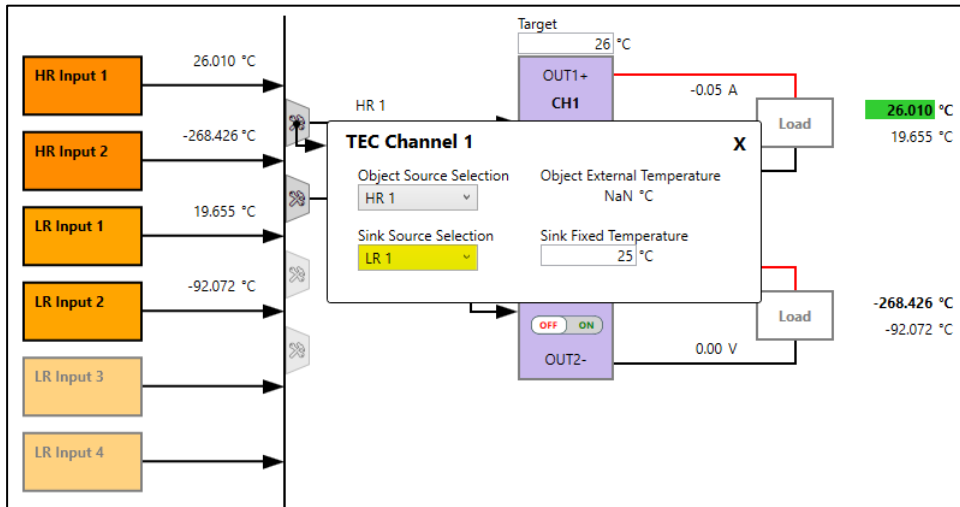

Figure 11: Configuration Popup for TEC Channel 1 in the main window.

Heat sink measurement improves the performance of the integrated power optimization routine but is optional. It is possible to use a fixed temperature value as reference if no external heat sink measurement is used. This can be done in the TEC Channel configuration popup in the main window by setting by setting the "Sink Source Selection" to "Fixed" and entering the desired reference temperature in the "Sink Fixed Temperature" field to the right of it.

Table 8: Parameter "Sink Source Selection"

Option	Description
HR 1	The temperature of HR 1 (High Resolution Measurement Circuit 1) is used for temperature controlling.
HR 2	The temperature of HR 2 (High Resolution Measurement Circuit 2) is used for temperature controlling.
LR 1	The temperature of LR 1 (Low Resolution Measurement Circuit 1) is used for temperature controlling.
LR 2	The temperature of LR 2 (Low Resolution Measurement Circuit 2) is used for temperature controlling.
LR 3	The temperature of LR 3 (Low Resolution Measurement Circuit 3) is used for temperature controlling.
LR 4	The temperature of LR 4 (Low Resolution Measurement Circuit 4) is used for temperature controlling.
Device	The Device Temperature of the TEC Controller is being used.
Fixed	The temperature can be set to a fixed temperature value as reference when no sink sensor measurement is used. Define this temperature value through the "Sink Fixed Temperature" parameter (ID 52201).

4 Temperature Control

This chapter covers the "Temperature Controller" window of the TEC Configuration Software.

4.1 Theory of Operation

The following part is a short description of the temperature control mechanism in the TEC Controller.

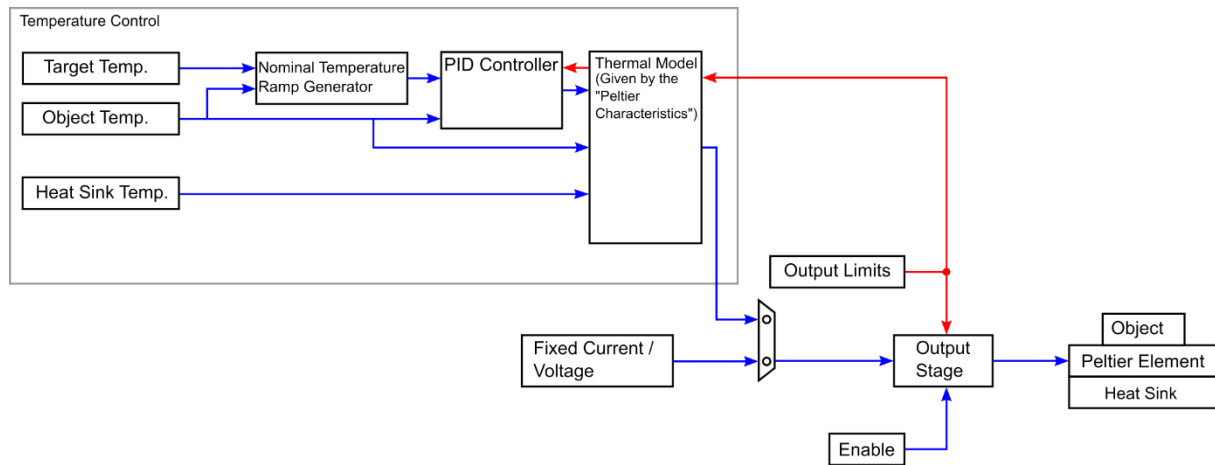

Figure 12: Temperature control functional overview.

- The TEC Controller measures periodically the object temperature and the temperature of the heat sink (optional) using temperature sensors. The temperature measurement is also active when the temperature controller is not.
- The target temperature is the setpoint for the PID controller.
- The temperature controller calculates the needed output power based on the target temperature, heat sink temperature and actual object temperature. It's possible to use a fixed value for the heat sink temperature (default setting).
- The output stage has two possible input parameters, either the value from the temperature controller or a static current and voltage.
- To keep the output stage in boundaries, output limits are set.
- The output stage is enabled and disabled by the enable parameter.
- Finally, the output stage powers the Peltier element.

4.1.1 PID Control Parameters

- The proportional term **K_p** defines the portion [%] of normalized cooling/heating power that can be used to correct the difference [°C] between actual and nominal temperature. Assuming the temperature difference between actual and nominal is 2°C and K_p is set to 15%/°C, then the output will feed 30% power to the Peltier element.
- The integral term **T_i** defines the reset time [s] the regulator is allowed to take for correcting a given control deviation. The effect of T_i is weak for large values and strong for small values. Set T_i to 0s to disable the integral term.
- The derivative term **T_d** opposes changes in control deviation, weighed by unit time [s]. The dampening effect of T_d increases with larger values. By default, the D component is bypassed (0s).
- The value "D Part Damping PT1" is damping the resulting value of the derivative term. It may be useful for very slow thermal models which result in high T_d times.

The suggested PID values are starting values that proved to work reasonably well at factory. At a later stage, you can optimize them for your application and system. This can be done manually or by using the auto tuning function in the Configuration Software.

4.1.2 Temperature Ramp

For certain thermal masses, the systems response to cooling and heating power may be slow and thus reaching thermal stability takes some time. On power-up large changes from an initial to a target temperature may be required. To minimize the overall time to reach thermal stability, the sudden jump in temperature is replaced by a generated three-part ramp.

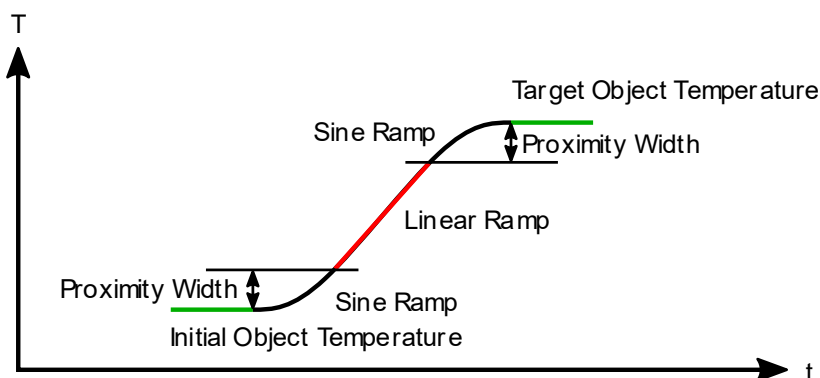

Figure 13: Temperature vs time change from an initial temperature to a target temperature, showing the three-part ramp.

First the nominal temperature is smoothly guided away from the starting value by a sine-shaped curve. After leaving the "Proximity Width" the temperature follows the faster, linear ramp—the "Coarse Temp Ramp"—at the maximum possible rate. Once again within the "Proximity Width", the nominal temperature follows again a sine-shaped curve towards the target temperature. Using this ramping scheme, over- and undershoots in respect to the target temperature will be minimized and the final temperature is stabilized more quickly.

If a Linear Ramp without the sine shaped curves is required, the Proximity width can be set to 0.

It is unlikely that your system can follow the default "Coarse Temp Ramp" slope of 1 °C/s. This initial setting allows the user to get a feeling for the system's thermal inertia, and it permits observation of the nominal temperature trace in the graph.

Nominal temperature ramping allows the usage of more aggressive PID values, typically required to properly react to external disturbances. Please note that the ramping and PID parameter sets are independent.

4.2 Control Modes

The TEC Controller supports the following three control modes, available in the field "Thermal Model Selection":

- **Peltier, Full Control:** The Peltier element heats and cools, powered by the bipolar current.
- **Peltier, Heat/Cool Only:** The TEC Controller tries to keep the temperature between the "Peltier, Heat/Cool Only Boundaries". If the actual temperature is somewhere between these boundaries, the TEC Controller does not power the Peltier element.
- **Resistor, Heat Only:** If a resistive heater is used, only heating is possible.

Depending on what you choose, either "Peltier Characteristics" or "Resistor Characteristics" parameters will be implemented (from either of the two boxes underneath).

4.3 PID Auto Tuning (PID Parameter Optimization)

The "Auto Tuning" window in the Configuration Software provides a powerful tool for system optimization. The results are optimized PID controller and ramping parameter sets (see chapter [4.1 Theory of Operation](#)). The "Auto Tuning" window can be accessed through a button below the "Temperature Control" box in the "Temperature Controller" window of the channel that should be optimized.

Precautions:

- If you have set the "Thermal Model" in the "Temperature Controller" window to "Peltier, Heat/Cool Only" mode the Auto Tuning will not work unless the controller is actively regulating, i.e., the current object temperature is outside the two defined boundaries. It rarely makes sense to perform the Auto Tuning in such circumstances. Instead, consider setting the "Thermal Model" to "Peltier, Full Control" and the "Target Temperature" to a value between the boundaries to perform the Auto Tuning and afterwards set the "Thermal Model" back.
- If you have set the "Thermal Model" in the "Temperature Controller" window to "Resistor, Heat Only" mode the Auto Tuning will not work unless the controller is actively heating, i.e., the current object temperature is below the "Target Temperature". In most cases it makes more sense to try and manually optimize the PID settings instead of performing the Auto Tuning in this mode.
- If the "Temperature Controller" is operating in Unipolar Mode the actor must be naturally controlled, i.e., it must be either heating or cooling when the Auto Tuning function is started.

Follow these steps to optimize your system:

- The "Thermal Model" in the "Temperature Controller" window should be set to "Peltier, Full Control".
- The temperature measurement should work reliably, prior to using the auto tuning function. This means that the correct temperature is measured, and the fluctuation of the temperature value is small (i.e., < 5 mK).
- Ensure that the Peltier element is connected with the correct polarity.
- Peltier characteristics (in the "Temperature Controller" window) must be set correctly according to the Peltier element's datasheet.
- Set limits for current and voltage in the "Temperature Controller" window.
- Make sure that the output stage is not running in its voltage limitation.
- Set the temperature limits in the "HR Input x" window, to avoid damage of anything in contact with the Peltier element.
- Set the desired object target temperature. If you will use multiple target temperatures, use the highest one. This leads to more reliable PID values in most cases.
- The channel to be optimized must already be successfully operating in the mode "Temperature Controller". This means that the target temperature is reached with the standard PID settings ($K_p = 10$; $T_i = 300$; $T_d = 0$).
- Before you start the auto tuning process, it is recommended to note the currently used PID values in the "Temperature Control" box and the parameters in the field "Nominal Temperature Ramp" or to export the device configuration.
- During the optimization process, no other heating or cooling source other than the driven Peltier element must be active, to not disturb the process.
- Enable the temperature controller by setting the option "Output Enable" in the "Temperature Controller" or main window to "ON".
- **Important:** Wait until the target temperature is reached and the temperature has equalized.
- Select the "Thermal Model Speed":

- "Fast Model": Use this setting if you have only a small thermal load and the target temperature is usually reached within a minute. Always start with this setting.
- "Slow Model": Use this setting if you have a huge thermal load and the target temperature is usually reached within some minutes.
- Now the status indicator reads "Idle". Press the "Start" button.
- The TEC Controller initiates a cooling-heating pattern that will reveal specific system information. The progress of the auto tuning procedure is indicated by the advancing status bar. You can observe the applied current patterns and resulting temperature variations in the "Chart" window if you display the respective parameters within it.
- Upon ending with the status "Successful" the TEC Controller will continue regulating the temperature.
- Finally, the results of the optimization are displayed in the fields within the "Check Tuning Results" box. You can accept and use the new parameters by clicking on the "Write Results" button.

4.3.1 Trouble Shooting and Enhancements

Table 9: Possible reasons and possible solutions for common problems during auto tuning.

Problems	Possible Reasons	Possible Solutions
There is too much noise on the current output.	Your thermal model is very slow. Therefore, large Ti and Td times are calculated for the PID controller. High Td times result in a very big amplification of every small temperature difference or noise.	Set the "Thermal Model Speed" to "Slow Model" and start the auto tuning process again.
		Check "Use Slow PI Values" and click on "Write Results". These values run without differential part of the PID controller.
		Go to "Temperature Controller" window and set "D Part Damping PT1" to a lower value. (Too low values will result in a worse temperature control behavior)
It takes too long until the desired target temperature is reached. The nominal temperature ramp is too slow. The TEC Controller is not providing the maximum current to the Peltier element.	After performing the Auto Tuning, the "Nominal Temperature Ramp" settings ("Coarse Temp Ramp" and "Proximity Width") are taken from Auto Tuning recommendations. These recommended values are intentionally slow values. The target is to prevent a temperature overshoot. Therefore, the PID controller must always be able to follow the nominal temperature ramp.	You may set "Coarse Temp Ramp" in the "Temperature Control" tab to a higher value. This will result in a faster nominal temperature ramp. You may set the "Proximity Width" to a lower value.
Error 170: Less than xx% of progress advancement in xx minutes.	The progress of the Auto Tuning is determined upon several parameters. This error is generated when the process is too slow.	Set "Thermal Model Speed" to "Slow Model" to have longer time periods.
		Let your thermal system cool down between two tuning attempts. Disable the power source to the Peltier element for several minutes.

Problems	Possible Reasons	Possible Solutions
Error 171 / 172: Auto Tuning fails at three consecutive attempts due to more than 40% discrepancy in temperature / time.	The tuning process executes several swing periods to determine the results. This error is generated if values of these swing periods are too different.	Do not change the thermal load during the tuning process.
		Make sure the thermal object is isolated from any changing air flows.
Error 173: Auto Tuning detects that the PID temperature controller is in limitation.	TEC Controller is not Running in Temperature Controller Mode.	Make sure that the TEC Controller's output stage is "ON", and that the TEC Controller's "Output Stage Control Input" is set to "Temperature Controller".
	The Target Temperature has not been reached. The Temperature Controller is running in its output limitation.	Make sure you use suitable default PID Settings. These are described in the Configuration Software "Auto Tuning" window.
		Make sure the target temperature has been reached and equalized before you start the Auto Tuning process.
Auto Tuning is stuck in "Preparation" status	The "Thermal Model Selection" is set to either the "Peltier, Heat/Cool Only" or the "Resistor, Heat Only" mode. In those modes the Auto tuning can only work while the TEC Controller is actively regulating the temperature.	Make sure that the temperature is being actively regulated before starting the Auto Tuning process.
		If you are using the "Peltier, Heat/Cool Only" mode consider setting the "Thermal Model" to "Peltier, Full Control" and the "Target Temperature" to a value between the boundaries to perform the Auto Tuning and afterwards set the "Thermal Model" back.
		If you are using the "Resistor, Heat Only" mode it makes more sense in most cases to try and manually optimize the PID settings instead of performing the Auto Tuning in this mode.

4.4 Operating Modes & Parallel Operation

TEC Controllers having two output stages can operate them independently or in a combination in various modes. In the main window the "Operating Mode" can be set to the following options:

- **Bipolar:** This is the default setting. Each channel can use any temperature measurement and uses its own output stage. Each channel can output positive and negative current / voltage.

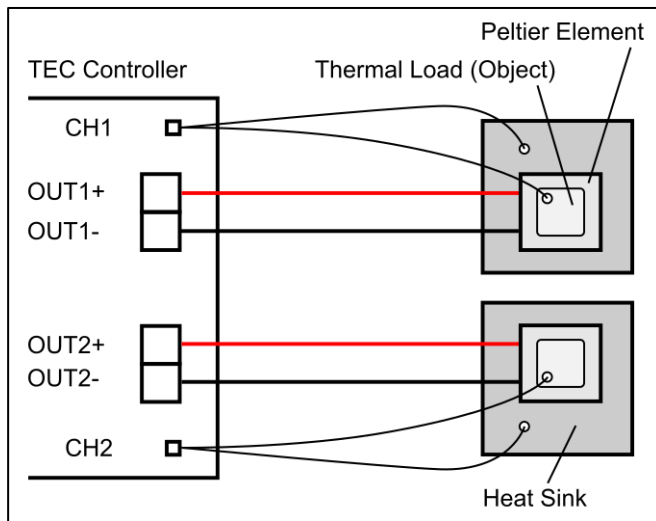

Figure 14: Example of a dual-channel TEC Controller controlling two thermal loads, each with their own Peltier element, heat sink, HR, and LR temperature measurements in Bipolar mode.

- **Parallel Bipolar Individual:** The output current, output voltage values as well as all output stage limits of channel 2 are set to the ones currently active for channel 1. The "Output Stage Enable" status of CH1 is also valid for both channels.

In practice, this means that the CH2 output stage will follow the settings defined for the CH1 output stage.

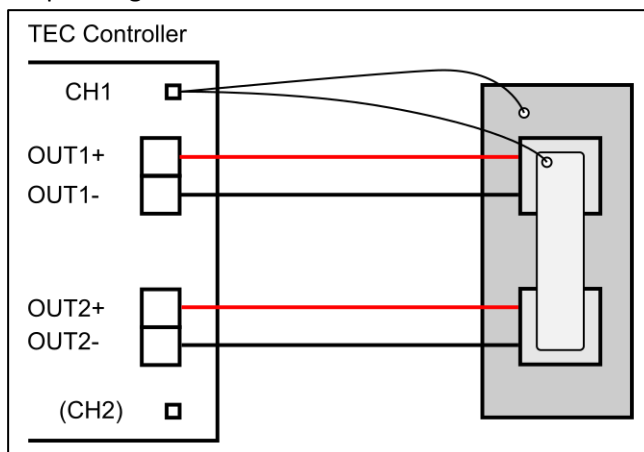

Figure 15: Example of a dual-channel TEC Controller controlling two thermal loads mounted on a single heat sink with only one object and one heat sink temperature measurement in Parallel Bipolar Individual mode.

- Parallel Bipolar Common:** This mode allows for current doubling. The outputs of the two output stages are connected to one common load. If CH1 is working as "Temperature Controller", the PID controller is aware it can dispose twice the nominal current, to which each channel will provide an equal amount.

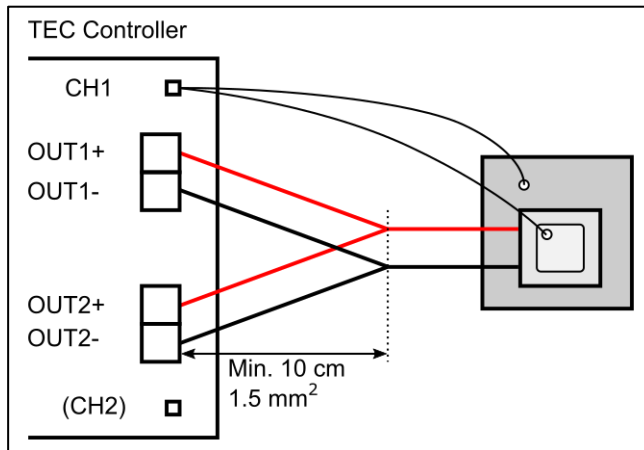

Figure 16: Example of a dual-channel TEC Controller controlling a single thermal load by connecting both outputs to it, which allows for current doubling in Parallel Bipolar Common mode.

- Unipolar:** The output stages are each split into two channels each, which can only either output positive or negative current / voltage. This allows the temperature controlling of more loads. The LR inputs can also be used to measure the temperatures of the additional loads.

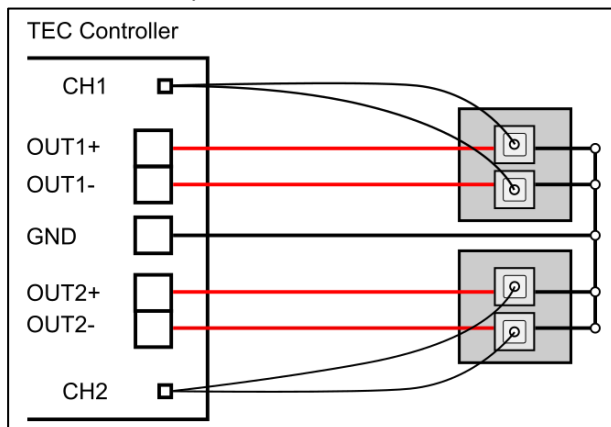

Figure 17: Example of a dual-channel TEC Controller whose outputs have both been split so that they can each control two thermal loads in Unipolar mode.

- **Mixed:** The output stages are split into one bipolar channel and two unipolar channels. This mode is only supported on devices with more than one output stage.

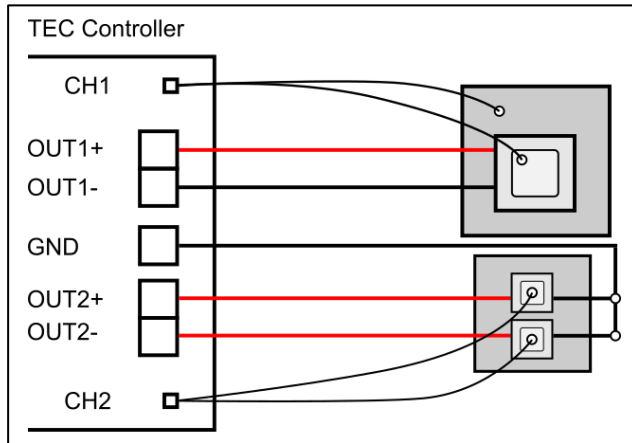



Figure 18: Example of a dual-channel TEC Controller that uses one output in Bipolar mode to control a single thermal load and one output in Unipolar mode to control two additional thermal loads.

5 Charting and Data Logging

5.1 Charts/Graphs

The graphs support multiple interaction options to adjust the view. The following interaction options can also be seen by hovering over the  symbol in the top-right corner of the graph windows:

Option	Keyboard Shortcut
Show Datapoint Details	Left Mouse Button
Pan	Right Mouse Button
Zoom	Mouse-Wheel
Zoom by Rectangle	Ctrl + Right Mouse Button
Reset	Double-Click Middle Mouse Button
	Double-Click Ctrl + Right Mouse Button

5.1.1 Graph

The "Graph" window offers a convenient way of mid-term system characterization, e.g., for observing stability, or for optimizing PID control or nominal temperature ramping parameters.

All numerical parameters present on a TEC Controller can be displayed in any of the graphs. To display a parameter in any of the two graphs, click on the "Graph Parameter Settings" button in the "Graph" window, which will open the "Application Settings" window. In this window all parameters of the TEC Controller are listed in a table within the "Graph Parameter Configuration" box. In this table a parameter can be shown by clicking on the checkbox in the "Show" column and it can be assigned to a specific graph via the dropdown menu in the "Assignment" column.

Furthermore, a parameter can also be shown in the graph by enabling the "Show in Graph" checkbox within its tooltip in the software.

By default, the graph will display the datapoints within a 10-minute range and it will always scroll the graph area automatically should the datapoints move out of the maximum boundary of the X axis (time). The time range can be adjusted by modifying the "Graph Area [min]" setting and the automatically scrolling behavior can be disabled by enabling the "Freeze Graphs" option within the "General Settings" box.

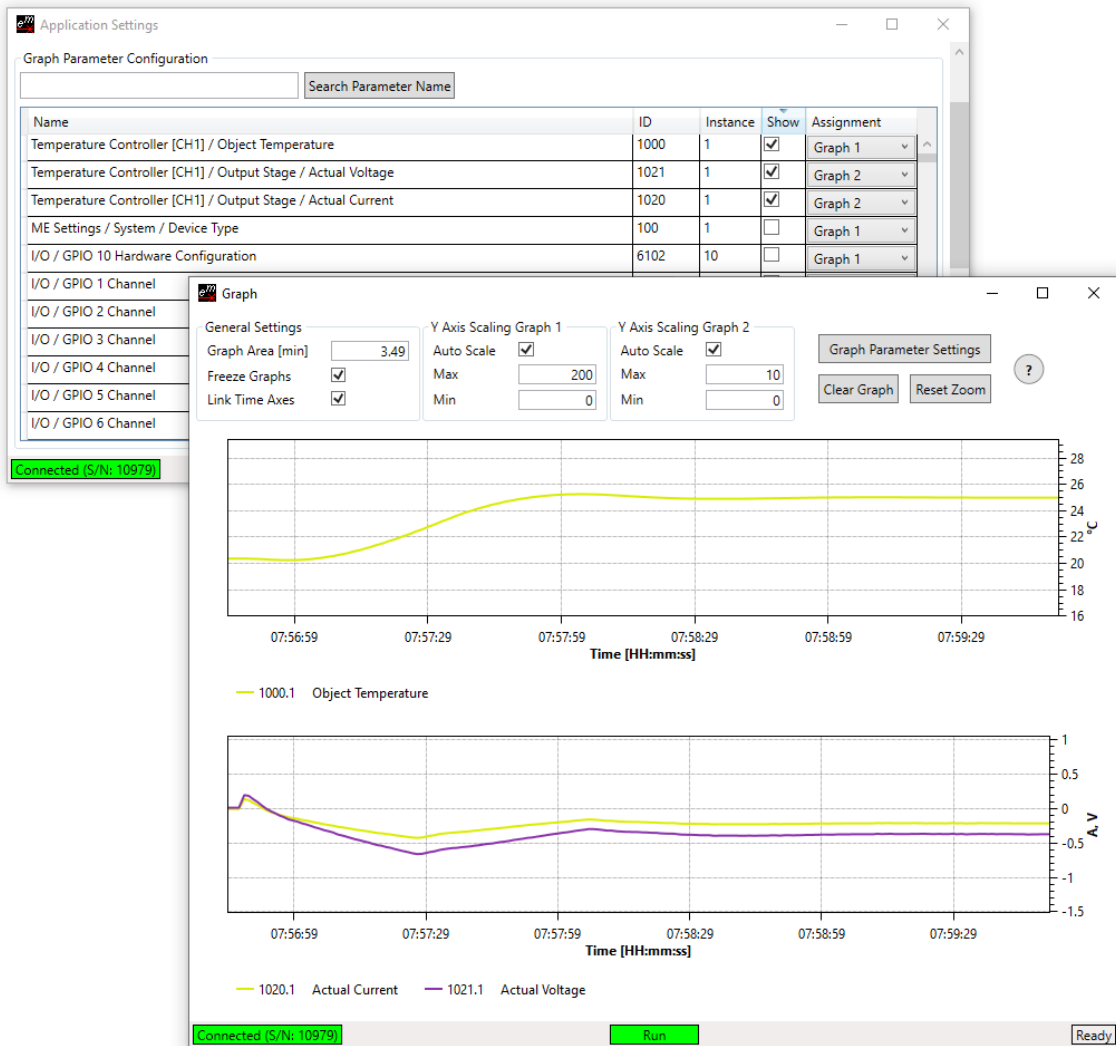

Figure 19: "Graph" window with its configuration in the "Application Settings" window on top.

5.1.2 Real Time Graph

When a TEC Controller in combination with a small thermal load (e.g., a sensor) is used, the object temperature may change quickly. To examine the behavior of a fast-changing system, the TEC Configuration Software features a DSO-like "Real Time Graph" feature.

- Compared to the normal chart, the real time chart has a higher temporal resolution and can record values down to a 10-millisecond interval.
- The Real Time Graph works using a Parameter subscription-based approach. It is possible to subscribe to any parameter that is available on the controller, which results in the controller recording any parameter writes of these parameters specifically for the Real Time Graph and Real Time CSV Log.
 - Parameters can be subscribed to from within the "Application Settings" window, which can be opened by clicking on the "Graph Parameter Settings" button in the "Real Time Graph" window.
 - Up to 16 parameters can be subscribed to at the same time.
 - In the "Real Time Graph Configuration" section in the "Application Settings" window it is possible to load a Default Profile that contains a few common parameters for the Real Time Graph feature to subscribe to. It is possible to also add or remove parameters that should be subscribed to after loading a default profile.
 - The parameters that should be subscribed to are listed in the table within the "Data Capture Configuration" section. Together they are what is referred to a "Capture Configuration" and to load this configuration onto the TEC Controller, so that it can start collecting data according to it, the "Update Capture Configuration" button needs to be pressed.
 - In the "Capture Configuration" table it is also possible to configure the following options for each parameter:

Option	Description
Inhibit Time	The inhibit time (capture delay time) specifies the minimum length of time that must be allowed to elapse between the capture of two of the same value. It can be used to implement a transmit filter that does not increase the reaction time for relatively new input alterations but is active for writes that follow immediately afterwards.
Assignment	Choose whether the parameter should be shown in graph 1 (top) or graph 2 (bottom).
OnWrite	Disclaimer: This option is only relevant for the CSV export of the Real Time Graph data. If this option is null (not set), then values are written to the file, whenever one value has been written. This might lead to a situation, where the time step is not the same for every row. If this option is enabled, it is possible to write only to the file, if the value of the selected index has been written. This also means that this option can only be active for one parameter at a time.

- Once the TEC Configuration Software is closed the configured "Capture Configuration" is discarded and needs to be manually configured again.
- Pressing the "Load Data" button in the "Real Time Graph" window displays the data recorded within the defined "Capture Time Frame [sec]" time section.

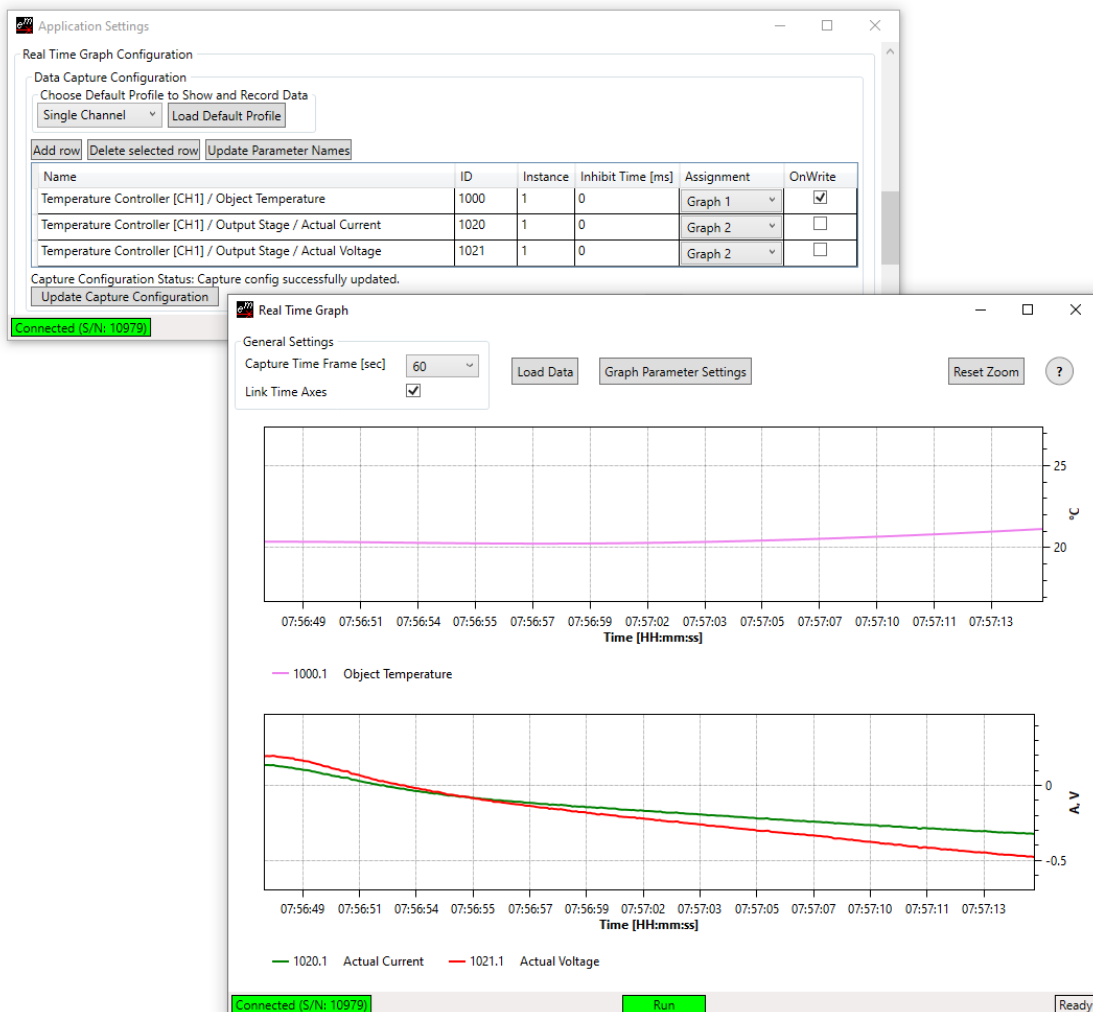

Figure 20: "Real Time Graph" window with the configuration for the object temperature (top) as well as output current and output voltage (bottom).

5.2 Log

For external plotting and data analysis, logged data can be exported to an .xlsx (Excel) or .csv (Comma-separated values) file from the "Log" window.

- Each log entry is timestamped.
- At relaunch of the software the log is erased, and the log interval is set to the smallest value of 1 second.
- The general data logging duration is limited to 10 hours. Afterwards, the data at the beginning of the log will be overwritten with any new log data (ring buffer).
- The graph makes use of this log data for its datapoints.
- For critical long-term monitoring we recommend exporting the log regularly and to relaunch the TEC Configuration Software occasionally (e.g., every couple of days).
- The export of the logged data contains all data of every single parameter on the controller.
- Certain parameters are logged only when they are changed (Setting parameters) and others are logged upon every interval tick (Monitor parameters). In the Excel log these two types of parameters are each divided into their own worksheets, but in the CSV log all values are combined and written on each entry. This is why the CSV log can grow larger in file size in comparison with the Excel log the more entries the log contains.

5.3 Real Time CSV Log

Real time data logging to .csv files is possible.

- Data is transferred in a kind of stream from the TEC Controller to the TEC Configuration Software. After starting the logging, the file is kept open by the TEC Configuration Software and continuously written to. The file is only closed when the logging has been stopped.
- Every 10 milliseconds the TEC Controller will record the data of the parameters that are subscribed to using the "Capture Configuration" of the "Real Time Graph" feature.
- Every parameter present in the "Data Capture Configuration" in the "Application Settings" window is exported to the .csv file and marked with a time stamp.
- When the "Fill" checkbox is not checked, the CSV output only writes the column values to the rows, which have changed. If it is checked all columns are always filled with values, even if a value has not changed in the last log record. If the value has not changed, it will just take the last recorded value available.

Some adjustments are necessary within Microsoft Excel after the export due to the lack of formatting options in .csv files:

1. Open the exported .csv file.
2. Select the field C2.
3. Double-click on the square in the bottom right corner → the column is filled with values.
4. Copy your desired format from L1, e.g., "TT.MM.JJ hh:mm:ss.000" or the other one for users with a comma as decimal separator adjusted operating systems.
5. Select the entire column C by clicking on the column's header.
6. Go to the formatting options by right-clicking on the column and selecting "Format Cells...".
7. Choose the category "Custom", paste the format copied prior and click OK → the time in the column C is now displayed in millisecond resolution.
8. Analyze the data by using calculations and adding diagrams.
9. Save the log as Excel file.

6 External Hardware

6.1 GPIO1 – GPIO10 Control Signals

The GPIO1–GPIO4 control signals are available on every TEC Controller model and can be used for general purpose I/O (GPIO) or for predefined functions. The functions described in [Table 10](#) can be independently assigned to the GPIO signals in the "I/O" window. Many functions are separately available for both channels. For those functions, the corresponding channel can be chosen in the "I/O" window as well. For the functions which are not available separately this setting has no effect.

Table 10: Available functions for the GPIO signals

Function Name	Description
No Function	The GPIOx has no function.
Data Interface	The GPIOx signal is used as digital I/O from the communication interface. Refer to the document " TEC Controller Communication Protocol 5136 " for more information. Not available individually for both channels.
TEC OK	The GPIOx signal is logic 1 if the TEC Controller is in the "Ready" or "Run" status. Not available individually for both channels.
Stable	The GPIOx signal is logic 1 if the temperature of the corresponding channel is stable.
HW Enable	The GPIOx signal is used as input to enable the output of the channel. If the signal is logic 1, the TEC Controller is enabled. The value of parameter 2010 will be overwritten with the value provided by the GPIO.
Fan PWM	The GPIOx signal is used as PWM output for the Fan Control feature. Only selectable for GPIO3 and GPIO4 (see chapter 0 Fan for Heatsink Cooling). For this function, the "Hardware Configuration" is usually set to "Out Push-Pull" to properly drive the PWM input of the fan.
Fan Tacho	The GPIOx signal is used as frequency input for the fan control feature (see chapter 0 Fan for Heatsink Cooling). For this function, the "Hardware Configuration" is usually set to "IN Weak Up", because the tacho output of the fan usually has an open collector output.
Rmp/Stable	The GPIOx signal is logic 1 if the temperature of the corresponding channel is stable. The GPIOx signal toggles between 1 and 0 at 1 Hz, when the corresponding channel is ramping to the target temperature.
TEC Run	The GPIOx signal is logic 1 if the TEC Controller is in the "Run" status. Not available individually for multiple channels.
TempUp TempDown	The GPIOx signal is used as input signal. At every positive edge (transition from logic 0 to logic 1) the target temperature is increased or decreased by the chosen step size. If the signal is logic 1 for longer than 1 s, the target temperature is changed with increasing speed in the chosen direction (see chapter 6.1.1 Buttons for more information). Pressing both buttons simultaneously for 6 seconds locks or unlocks the buttons.
Pump	The GPIOx signal is set to logic 1 to enable a pump. Use the "CHx Pump Control" settings to configure the behavior.
Lookup Start	The GPIOx signal is used as input signal. A positive edge starts, and a negative edge stops lookup table execution. By default, the table ID 0 is executed. The ID to be executed is a volatile setting; it is possible to change it over the communication interface.

Function Name	Description															
Dev Adr +1 Dev Adr +2 Dev Adr +4	The GPIOx signal is used as input signal. For each pin which is logic 1 and with this function enabled, 1, 2 or 4 is added to the device address. This is only done once at startup.															
Fan Stop	The GPIOx signal is used as input signal. If this function is enabled and the corresponding pin is 1, the fan is disabled. If the pin is 0 the fan runs normally.															
Alt Target Tx	The GPIOx signal is used as input signal. This function allows to select up to 4 different target temperatures, by changing the signal level of the pins. The value of parameter 3000 will be overwritten with these temperature values.															
	<table border="1"> <thead> <tr> <th>CHx Alt Target T2</th> <th>CHx Alt Target T1</th> <th>Selected Target Temp</th> </tr> </thead> <tbody> <tr> <td>0</td> <td>0</td> <td>"Temperature 0" from "GPIO Detail" options</td> </tr> <tr> <td>0</td> <td>1</td> <td>"Temperature 1" from "GPIO Detail" options</td> </tr> <tr> <td>1</td> <td>0</td> <td>"Temperature 2" from "GPIO Detail" options</td> </tr> <tr> <td>1</td> <td>1</td> <td>"Temperature 3" from "GPIO Detail" options</td> </tr> </tbody> </table>	CHx Alt Target T2	CHx Alt Target T1	Selected Target Temp	0	0	"Temperature 0" from "GPIO Detail" options	0	1	"Temperature 1" from "GPIO Detail" options	1	0	"Temperature 2" from "GPIO Detail" options	1	1	"Temperature 3" from "GPIO Detail" options
	CHx Alt Target T2	CHx Alt Target T1	Selected Target Temp													
	0	0	"Temperature 0" from "GPIO Detail" options													
	0	1	"Temperature 1" from "GPIO Detail" options													
1	0	"Temperature 2" from "GPIO Detail" options														
1	1	"Temperature 3" from "GPIO Detail" options														
PowerSt 0A	The GPIOx signal is used as input signal. If the signal is 1, the output current for the corresponding channel is set to 0 A, without disabling or reinitializing the temperature controller. This can be useful for critical measurement cycles.															
Encoder A Encoder B	The GPIOx signal is used as input signal. A Rotary Encoder is to be connected to the Encoder A and Encoder B inputs. It can then be used to change the target temperature.															
Ramp	The GPIOx signal is 1, when the corresponding channel is ramping to the target temperature.															
Fix 0	Just sets the output to fix 0. Can be inverted using the "Level Assignment".															
HW Enable Toggle	The signal is used as an impulse to toggle the output between on and off.															

The Logic Level of each pin can be assigned under "Level Assignment" in the collapsed "GPIO General" options within the "I/O" window. For inputs, Logic Level Positive means that a high voltage is read in as logic 1 while a low voltage (Pin connected to GND) is logic 0. This can be inverted by setting the parameter to "Negative". For outputs, the logic level inverts the Signal when set to "Negative". This means that for example the "TEC OK" signal outputs 0V when the TEC is in "Ready" or "Run" status and the "Level Assignment" is set to "Negative".

The pins can be individually configured under "Hardware Configuration" in the "I/O" window. When a signal is used as an input the hardware configuration must be made accordingly or the function will not be operational. The hardware configuration is described in [Table 11.5](#)

Table 11: GPIO Pins Hardware Configuration

Function Name	Description
IN WeakNo	The GPIO Pin is configured as Input. No PullUp or PullDown Resistor is activated.
IN WeakUp	The GPIO Pin is configured as Input. A weak PullUp Resistor to 3.3V of approximately 50kΩ is activated.
IN WeakDown	The GPIO Pin is configured as Input. A weak PullDown Resistor of approximately 50kΩ is activated.
OUT PushPull	The GPIO Pin is configured as Push Pull Output. No PullUp or PullDown Resistor is activated.
OUT OD NoPull	The GPIO Pin is configured as an Open Drain Output. No PullUp or PullDown Resistor is activated.
OUT OD WeakUp	The GPIO Pin is configured as an Open Drain Output. A weak PullUp Resistor to 3.3V of approximately 50kΩ is activated.

For input signals like buttons, it is usually easier to set the pin to "Negative" logic and "In Weak Up". This way the switch can be connected between the GPIO pin and GND.

6.1.1 Buttons

The target temperature can be changed through two buttons connected to the GPIO connector.

- It is recommended to connect the buttons between the GND pin and another GPIOx pin and set the Hardware Configuration to "IN WeakUp" and use negative logic.
- Pressing both buttons simultaneously for 6 seconds locks or unlocks the buttons.

The Buttons can be configured in the "I/O" window within the collapsed "GPIO Detail" options. See Table 12 for a description of the settings.

Table 12: CHx Target Temperature Button Configuration

Parameter Name	Description
Upper Temperature Limit	Specifies the maximum Target Temperature which can be set by using the up button.
Lower Temperature Limit	Specifies the minimum Target Temperature which can be set by using the down button.
Step Size	Specifies the single step size, applied on every edge.

6.1.2 Rotary Encoders

The target temperatures can be changed by connecting a rotary encoder for each channel to the GPIOs.

- It is recommended to connect the rotary encoder common connection to GND and the outputs to the GPIOx pins.
- With continuous rotation the step size is automatically increased to facilitate large changes in the target temperature.
- The direction of rotation in which the target temperature is increased or decreased can be changed by swapping output A with output B and vice versa.

The "Step Size" and "Temperature Limit" settings from the "Channel x → Change Temperature Buttons" box in the "GPIO Detail" section in the "I/O" window are used for the Rotary Encoders.

6.1.2.1 Encoder Recommendations

Meerstetter Engineering has tested the following encoders which fulfill the above-mentioned requirements.

Manufacturer P/N	DigiKey P/N	Resolution
TT BI EN11-HSM1AF15	987-1188-ND	20 Pulses per Revolution
Bourns PEC11R-4215F-N0024	PEC11R-4215F-N0024-ND	24 Pulses per Revolution
Panasonic EVE-WRHJR012B	P15917-ND	12 Pulses per Revolution

6.1.3 Fan for Heatsink Cooling

Up to two fans can be connected and controlled by the TEC Controller. The "Fan Control Feature" is intended to keep the heatsink temperature below a specified temperature, by using the slowest fan speed possible. Please refer to chapter 6.1 on how to configure the fan control signals.

6.1.3.1 Fan Requirements

The "Fan Control Feature" is only compatible to fans with the following features:

- PWM control signal input to control the fan speed. The TEC Controller generates a 25 kHz or 1 kHz PWM signal from 0 to 100%. 3.3 V voltage level.
- Optional, but recommended: Frequency generator signal output which represents the rotation speed. The output should be an open collector output signal.

For the logic level voltage definitions of the TEC Controllers, please refer to the datasheets.

6.1.3.2 Fan Recommendations

To obviate the need for a separate power supply, it is recommended to use a fan with the same supply voltage as the TEC Controller needs.

We have tested the following fans, which fulfill the above-mentioned requirements. All fans stop (0 rpm) at 0% PWM signal.

Table 13: Fan recommendations

Fan	Manufacturer P/N	DigiKey P/N	Voltage [V]	Power [W]	Dimensions [mm]		
					L	H	W
1	FFB0424VHN-TZT4	603-1818-ND	24	2	40	40	28
2	AFB0624EH-SP50	603-1803-ND	24	6	60	60	25
3	PFB0824DHE-YDG	603-2028-ND	24	32	80	80	38
4	AFB1224EHE-EP	603-1735-ND	24	20	120	120	38
5	FFB0412VHN-TP03	603-1206-ND	12	2	40	40	28
6	AFB0612DH-TP11	603-1211-ND	12	10	60	60	25
7	EFC0812DB-F00	603-1159-ND	12	4	80	80	15
8	FFC1212D-F00	603-1789-ND	12	17	120	120	25
9	PF40281BX-000U-S99	259-1666-ND	12	11	40	40	28

6.1.3.3 Optimized Settings

The following values are optimal settings for the Fan Speed Controller parameters of the TEC Controller in combination with the corresponding fan. The bypass option ("Bypassing Speed Controller") is used for fans with integrated speed controller, to disable the TEC Controller's speed controller.

Fan	0% Speed [rpm]	100% Speed [rpm]	Kp [%/rpm]	Ti [s]	Td [s]	Bypass
1	-	-	-	-	-	Yes
2	-	-	-	-	-	Yes
3	-	-	-	-	-	Yes
4	-	-	-	-	-	Yes
5	0	10000	0.005	0.5	0	No
6	0	10000	0.005	0.5	0	No
7	0	4200	0.005	0.5	0	No
8	0	4400	0.005	0.5	0	No
9	0	22500	-	-	-	Yes

6.1.3.4 Connecting the Fan to the TEC Controller

- If the fan supports the same supply voltage as the TEC Controller, it is recommended to connect the fan's GND and VCC to the TEC Controller's GND and VIN, respectively.
- If a separate power supply is used for the fan, make sure that the two GND terminals of the power supplies are connected. Never leave the fan's GND unconnected when the fan is powered. Otherwise, the GPIOx pins may be destroyed.
- Assign the correct function to the GPIO signals (see chapter [6.1 GPIO1 – GPIO10 Control Signals](#)).
- The PWM input of the fan must be connected to GPIO3 or GPIO4, since only these outputs generate a PWM signal. As an example, you can configure the GPIO as follows:
 - Pin: GPIO4
 - Function: Fan PWM
 - Level Assignment: Positive
 - Hardware Configuration: OUT PushPull
- The frequency output signal of the fan can be connected to any of the GPIO signals. As an example, you can configure the GPIO as follows:
 - Pin: GPIO3
 - Function Fan Tacho
 - Level Assignment: Positive
 - Hardware Configuration: IN WeakUp

6.1.3.5 Control Function

The Fan Control feature uses two PID controllers.

The first PID controller sets the required cooling power depending on the temperature of the heatsink. In most cases only P control is used. We recommend a value of 30 %/°C for Kp. Thus, for a target temperature of 40 °C the fan will rotate with 0% speed at 40 °C and 90% speed at 43 °C.

This required cooling power is then converted into a nominal fan speed. For example, if the minimum and maximum fan speeds are set to 1000 rpm and 11000 rpm, respectively, the required cooling power of 50% is converted into a nominal fan speed of 6000 rpm.

The second PID controller sets the fan speed by varying the PWM output signal until the nominal fan speed is reached.

The "Fan Speed Controller" should be set up before without temperature regulation of the heatsink. This can be done by setting both the "Target Temperature" and the "100% Speed" to a high value. This allows to use the "0% Speed" as a fixed rotation speed. The fan should reach the nominal speed as fast as possible.

It is possible to stop the fan by an external GPIOx signal. This is useful, e.g., if a door of a compartment is opened (see chapter [6.1 GPIO1 – GPIO10 Control Signals](#)).

If a hysteresis is needed the parameters "Min Speed Start" and "Min Speed Stop" can be used. If those values are set to zero, they will be ignored.

6.1.3.6 Fan Parameter Description

Table 14: CHx Fan Control Enable

Parameter Name	Options and Description
Fan Control Enable	<ul style="list-style-type: none"> Disabled Enabled: Enables the fan controller

Table 15: CHx Fan Temperature Controller

Parameter Name	Options and Description
Fan Temperature Source	<p>The Actual Temperature for the temperature controller is taken from:</p> <ul style="list-style-type: none"> HR 1: High Resolution Measurement Input 1 HR 2: High Resolution Measurement Input 2 LR 1 Low Resolution Measurement Input 1 LR 2: Low Resolution Measurement Input 2 LR 3: Low Resolution Measurement Input 3 LR 4: Low Resolution Measurement Input 4 Device: Device temperature of the TEC Controller <p>The assignment of the temperature source can be done in the main window in the following popups that lead to the "Fan Controller x" buttons:</p> 
Target Temperature	Target temperature (set point) for the temperature controller
Kp, Ti, Td	PID controller parameters for the temperature controller

Table 16: CHx Fan Temperature Controller

Parameter Name	Options and Description
0% Speed	Minimum rotation speed
100% Speed	Maximum rotation speed
Min Speed Start	Minimal speed above which the fan is started
Min Speed Stop	Minimal speed below which the fan is stopped
Kp, Ti, Td	PID controller parameters for the Fan Speed Controller
Bypassing Speed Controller	<ul style="list-style-type: none"> Yes: Disables the Fan Speed Controller. The "Relative Cooling Power" is written directly to the PWM output. No: The built-in speed controller is used.
Fan Surveillance	<p>Disables Error 175 (ERROR_FAN_CONTROL_LIMIT) and Error 176 (ERROR_FAN_BLOCKED)</p> <p>This can be used when no tachometer signal is available.</p>

6.2 Display Kits

Our optional OLED display kits (DPY-1113, DPY-1114 and DPY-1115), which feature either two lines with 16 chars or four lines with 20 chars, can be attached to our TEC Controllers out of the box. In case of the TEC-1092, the display kits can only be used in combination with the EVL-1093 evaluation board.

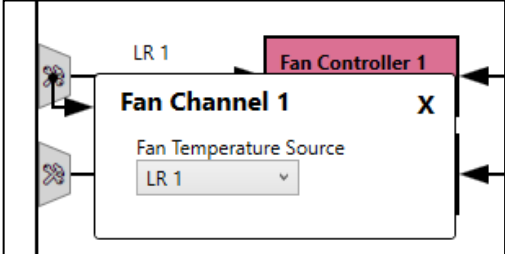
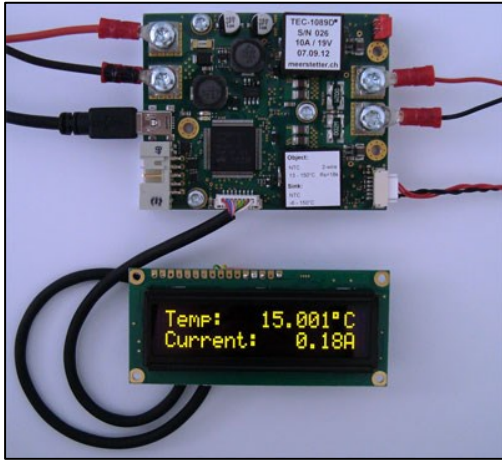

Figure 21: A DPY-1113 connected to a TEC-1089 TEC Controller, displaying the object temperature and the output current.

You must enable the respective display type and select the information to be displayed in the "Display" window of the TEC Configuration Software.

The TEC Controller must be reset before the Display becomes active.

Table 17: General Display Settings

Setting	Options	Description
Display Type	OFF	Disables the display feature
	OLED 2x16 (DPY-1113)	For display: DPY-1113
	OLED 4x20 (DPY-1114)	For display: DPY-1114
	Small OLED 2x16 (DPY-1115)	For display: DPY-1115
Line 1 - 4 Default Text	Various (see description below)	Defines the text to be displayed on the corresponding line.
Line 1 – 4 Alternative Text	Various (see description below)	Defines the text to be displayed for the alternative mode.
Line 1 – 4 Startup Text	Various (see description below)	Defines the text to be displayed at the startup of the controller.
Line 1 – 4 Alternative Mode	None	No alternative information is displayed.
	On Error	If the TEC Controller is in Error state, the alternative information is being displayed.
	Toggle on Error	If the TEC Controller is in Error state, the alternative information is being toggled with the default information.
	Toggle	The default information is toggled with the alternative information.

6.2.1 Display Text

The Display can be used to show fully user-configurable text including all accessible parameters.

Text consisting of standard characters will just be shown as is on the display. To incorporate parameters please follow the syntax described below. Multiple parameters can be displayed on a single line, the only limit is the numbers of characters of the display.

6.2.1.1 Displaying System Parameters

The syntax for the "Display Format Argument String" is as follows:

User Text: {Parameter Syntax} Other User Text

- **User Text**: Text defined by the user. Will be displayed as is.
- **{Parameter Syntax}**: System Parameter according to the syntax description below.
- **Other User Text**: Text defined by the user. Will be displayed as is.

Text and System Parameters can be displayed in any order and in any number, which enables the displaying of a vast variety of information.

User Text 1{Parameter Syntax}User Text 2{Parameter Syntax}{Parameter Syntax}User Text 3

6.2.1.2 Parameter Syntax

{Parameter ID;Parameter Instance;Fractional Points;Number of Digits;Argument Type;Argument ID}

Field	Value Range	Description
Parameter ID	0 – 65535	Parameter ID as described in the "TEC Controller Communication Protocol 5136" document.
Parameter Instance	1 – 255	Parameter Instance as described in the "TEC Controller Communication Protocol 5136" document. Usually, Instance 1 is TEC CH1 and Instance 2 is TEC CH2.
Fractional Points	0 – 6	Number of digits shown after the decimal point.
Number of Digits	0 – 13	Number of total digits shown.
Argument Type	0 – 1	Optional argument type 1 = Temp Format
Argument ID	Char	Optional argument ID Temp Format (1): C = Celsius (Default) F = Fahrenheit K = Kelvin

6.2.1.3 Examples

To further clarify let's take apart an example display text:

Object:{1000;1;2;5}°C

Object: Text defined by user. The Display will show "Object".

{1000;1;2;5} TEC Controller Parameter ID. Refer to section "Parameter Syntax". Display will show "23.12" (23.12°C is the Object Temperature measured by the controller).

°C Text defined by user. The Display will show "°C".

To get a better understanding of how to set display text here are some examples:

Text	Text Shown on Display	Description
Object: {1000;1;2;5}°C	Object: 23.12°C	Channel 1 Object Temperature
Sink: {1001;1;1;4}°C	Sink: 25.1°C	Channel 1 Sink Temperature
Current: {1020;1;2;4}A	Current: 1.22A	Channel 1 Actual Output Current
Voltage: {1021;2;2;5}A	Voltage: 4.23V	Channel 2 Actual Output Voltage
Target: {3000;1;2;5}°C	Target: 15.00°C	Channel 1 Target Temperature
Target: {3000;2;1;4}°C	Target: 20.0°C	Channel 2 Target Temperature
Status: {104;1;0;2}	Status: 2	TEC Controller Status
Stat: {104;1;0;2} Err: {105;1;0;2}	Stat: 1 Err: 0	TEC Controller Status and Error Number

The following configuration will show the object temperature of both channels and the output current and output voltage of both channels:

Table 18: Default Text Examples

Parameter	Text
Default Text 1	CH1 Temp: {1000;1;3;8}°C
Default Text 2	CH2 Temp: {1000;2;3;8}°C
Default Text 3	CH1: {1020;1;1;6}A {1021;1;1;6}V
Default Text 4	CH1: {1020;2;1;6}A {1021;2;1;6}V

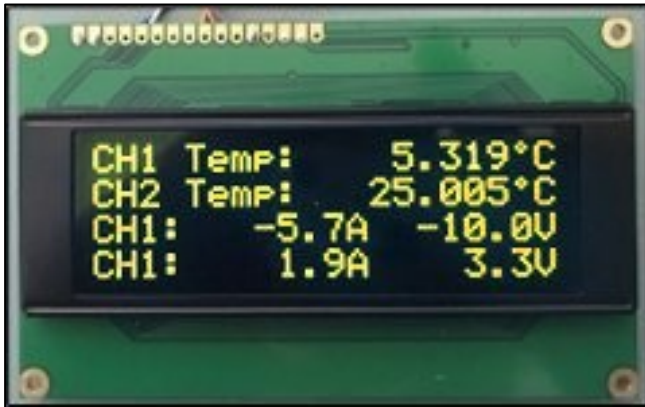

Figure 22: DPY-1114 Display (4x20 Characters) example.

6.2.1.4 Displaying Error Messages and Information

The TEC Controller can display an error description if needed. To do this, use the syntax described below:

{ERRMSG} A short error message is displayed. If there is no error, the TEC-Controller status is shown.

{ERRINF} Error information is displayed in the following way:
"Err: Error Number.Error Instance.Error Parameter".

If no error is currently present 0 is being displayed as error information.

7 Special Functions

7.1 Lookup Table Processing & Scripting

TEC Controllers can store and executing temperature profiles with predefined curves, ramps, slopes and hold times. These temperature profiles are defined with a script language.

Processing of lookup tables (LUT) is controllable over remote control. The MeCom communication protocol allows sub-table selection, choosing the number of repetitions, starting, and stopping the processing and reading status information. LUT processing can also be started over hardware GPIOx signals using the "Lookup Start" GPIO function.

7.1.1 Lookup Table Control from within the TEC Configuration Software

LUT processing is accessible in the Configuration Software in the "Lookup Table" window. Make sure that prior to using the lookup table processing, the TEC Controller is well tuned.

- Click "Load CSV File" to choose a LUT and save it to the controller's memory by clicking on "Download".
- For each TEC Controller channel, select the table ID and the number of executions.
- Click "Start" to enable processing of the table.
- While processing LUTs, the TEC Controller will ignore any other temperature settings, i.e., in the "Temperature Controller" window.
- Once all instructions of the LUT have been executed or when LUT control is cancelled, the channel of the TEC Controller returns to its previous state.

7.1.2 Instruction Set and Options

One single LUT instruction is defined as line with three elements, separated by semicolons:

```
Instruction; Field1; Field2
```

The second and third elements (Field1 and Field2) are not always used. However, make sure that the semicolons between the elements are still present on the lines of the lookup table as the lookup table file cannot be processed without these delimiters.

E.g., when using the "TILL_TEMP_STABLE" instruction write the following line:

```
TILL_TEMP_STABLE;;
```

Please note that the maximum number of instructions possible in a lookup table is 8192 instructions.

7.1.2.1 Table of Instructions

Type	Symbol Name / Range	Description
Instruction	TABLE_INFO	Start and End Markers of a defined portion (Sub Table) of the loaded Lookup Table. Table ID is selectable from within the TEC Configuration Software in the "Lookup Table" window.
Field 1 Option	START	Start of Sub Table
Field 1 Option	END	End of Sub Table
Field 2 Value	Range 0+INT32	Table ID (arbitrary identification number, set by user)

Type	Symbol Name / Range	Description
Instruction	SIN_RAMP_TO	Standard Sine Ramp
Field 1 Option	FROM_ACT	Ramp from Actual Object Temperature
Field 1 Option	FROM_NOM	Ramp from Latest Target Temperature
Field 2 Value	Range FLOAT32	Target Temperature in °C
Instruction	REPEAT_MARK	Repetition Markers. The instructions between START and END will be repeated a predefined number of times. The Number of Executions is selectable from within the TEC Configuration Software in the "Lookup Table" window.
Field 1 Option	START	Start of Repetition Field
Field 1 Option	END	End of Repetition Field
Instruction	LIN_RAMP_TIME	Linear Ramp between the Current Target Temperature to the New Target Temperature. Important: Make sure you use at least one "SIN_RAMP_TO / FROM_ACT" to have a defined behaviour from the current temperature to your first target Temperature.
Field 1 Value	Range UINT24	Ramp Time in ms (1000 = 1 second) Resolution 100ms
Field 2 Value	Range FLOAT32	New Target Temperature in °C
Instruction	STATUS	Instruction at the End of a Table
Field 1 Option	DISABLE	Disables the TEC Channel
Field 1 Option	ENABLE	Enables the TEC Channel
Instruction	EOF	End of File mark (must always be present as last instruction in the lookup table file)
Field 2 Value	CRC	The CRC is calculated and inserted by the TEC Configuration Software
Instruction	WAIT	Wait Instruction
Field 1 Option	FOREVER	Waits here forever (until the system is switched off or the Sub Table execution is cancelled)
Field 1 Option	TIME	Waits the time defined in Field 2
Field 2 Value	Range 0+INT32	Specifies the Wait Time in ms (only if Field 1 Option is TIME)
Instruction	SET_FLOAT	Set ME Parameter ID (see TEC Communicaton Protocol document)
Field 1 Value	Range UINT24	meParameter Number
Field 2 Value	Range FLOAT32	New Float Value
Instruction	SET_INT	Set ME Parameter ID (see TEC Communicaton Protocol document)
Field 1 Value	Range UINT24	meParameter Number
Field 2 Value	Range INT32	New Integer Value
Instruction	TILL_TEMP_STABLE	Wait until Temperature is stable
Instruction	SET_TARGET_INST	Change the Instance, which the Instructions should affect
Field 1 Value	Range UINT24	Not used. Write 0.
Field 2 Value	Range INT32	Instance Number

7.1.2.2 Value Range Definitions

Range Name	Description
0+INT32	0 ... 2147483647
FLOAT32	32-bit Float according to IEEE754
UINT24	0 ... 16777215
INT32	32-bit Signed Integer

7.1.3 Lookup Table Examples

Included with the "[TEC-Family TEC Controllers Software Package](#)" you will find two files with lookup table examples. If installed, click on the TEC Software "Additional"-Shortcut on your desktop. In this folder you can find the "Lookup-Table Dok" subfolder, which contains the two lookup table examples. The CSV files can be directly loaded onto a TEC Controller and the XLS files with the same names contain the same lookup table contents as the CSV files, but with explanations in the last column about what the used instructions do.

7.2 Advanced Misc Settings

7.2.1 Power Stage Overtemperature Behavior

The behavior of the firmware depends on the device temperature of the TEC Controller, which is regularly measured. Refer to the datasheet of the corresponding TEC Controller for more information about the current to temperature relationship.

The temperature behavior can be changed in the "View → Advanced Misc Settings" window via the menu bar of the main window.

Table 19: Device Temperature Mode (Output Stage)

Option	Description
Standard	Fixed error temperature limits are applied. If the device temperature reaches the limit, the OVERTEMPERATURE error is thrown.
Extended	The extended temperature range is enabled. Depending on the device temperature the current is being limited. You can find the corresponding limit curves in our TEC Controller Datasheets.

7.2.2 Error State Auto Reset Delay

If the system is in the error state, it restarts after a specified time. This feature is disabled if a time of 0 seconds is specified in the "Delay until Reset" parameter. The auto reset is delayed for a fixed time of 20 seconds after starting up.

7.2.3 Error 108 Delay

Error 108 occurs when Output Stage is in saturation for more than 1ms. It usually occurs when the controller wants to increase the output voltage but is unable to do so because the input voltage is too low. It can also occur in situations where it is unavoidable based on the system setup around the TEC Controller, which is why it is possible to adjust the conditions of this error or fully disable it if necessary.

By adjusting the time of the "Error Delay [CHx]" parameter the saturation error condition can be adjusted and by setting the parameter value to "-1" it will be completely disabled.

8 Appendix

8.1 Troubleshooting

Table 20: Typical Problems

Problems	Possible Reason	Possible Solution
The TEC Configuration Software is not starting	The required .NET Desktop Runtime is not installed on the system.	Make sure that you have the .NET Desktop Runtime installed on your system. See Download .NET (microsoft.com) .
I want to use a NTC10K sensor. Is it compatible with a NTC18K (or NTC39K, NTC56K, NTC1M) configuration?		Yes. See chapter 3.1.1.1 Example NTC Configuration for a detailed description.
The output is suddenly switched off	The "Upper and Lower Threshold" aren't set correctly.	Check the error message. Make sure that the "Upper Threshold" and "Lower Threshold" are set correctly in the "HR Input x" window.
The Peltier element is heating instead of cooling	The Peltier element is connected the wrong way.	Switch the wires of the Peltier element at the connector of the TEC Controller. Or switch "Positive current is" from heating to cooling in the "Temperature Controller" window.
	The parasitic heat generated in the Peltier module can no longer be dissipated.	Reduce the current and/or improve the cooling of the heatsink.
The firmware is too old	The firmware of the TEC Controller is too old to connect to the TEC Configuration Software.	Please update the firmware as described in chapter 2.5 Firmware Updates .
The temperature stability is worse than expected	There are several reasons, here are the most important ones: interference (temperature, electrical) temperature sensors are placed wrong.	To achieve a stable object temperature, the cold side and the object must be insulated from the environment. Check position and behavior of the temperature sensors.
CHx Output Stage Controller Limit (Error 108)	This usually happens if the TEC Controller's input voltage is too low for the desired output voltage.	Use power supply with sufficient output current and voltage.
		As a first measure, you may reduce the "Current Limitation" value in the "Temperature Controller" window.
TEC Controller can supply voltage but current is always close to 0 and there is no error shown	In most cases the Peltier element is defective.	Try swapping the Peltier element to see whether the problem persists.

8.2 Error Numbers, Instances and Parameters

- Error Numbers from 1 through 99 designate error conditions that are universal across the whole range of Meerstetter advanced TEC Controllers and laser diode drivers. Error numbers starting from 100 designate conditions that are specific to TEC-Family devices (see tables below).
- Error Instance typically designates the channel involved. For single-channel devices like the TEC-1091 it is 1. For two-channel devices like the TEC-1161, it can be 1 or 2.
- Error Parameters are additional information helping the software engineers at Meerstetter Engineering in the processes of error diagnosis or remote debugging.

8.2.1 Error Numbers 1 - 99 (Universal)

Table 21: Processor Errors

#	Description	Error Condition	Further Information
1–10 13–15	MCU system malfunction	-	Processor internal failure. If a reset or power cycle does not fix the issue, please contact the manufacturer.

Table 22: HMI Errors

#	Description	Error Condition	Further Information
11	Emergency stop was triggered by LTR-1200	-	Confirm whether you operate the LTR-1200 and the devices it contains within their specified limitations.
12	LTR-1200 HMI regularly sends 'free' signals to all rack-internal devices such that they can activate their output stages (if enabled)	No signal received for more than one second	-

Table 23: Parameter System Errors

#	Description	Error Condition	Further Information
20–21	Internal parameter system malfunction	Error occurs during reading or writing a parameter	Most likely a bug in the firmware, check if there is a new firmware version available or contact the manufacturer. It is also possible that the flash is defect.
22	Parameter set corrupt	Configuration flash empty or defect.	Load .xml file saved prior to FW update, or Default.xml
23	Parameter set incompatible with current firmware version	-	Load .xml file saved prior to FW update, or Default.xml

#	Description	Error Condition	Further Information
24	Firmware does not recognize valid device	Unknown device type, set the right device type (only possible by the manufacturer)	Contact the technical support of the manufacturer to resolve the issue.
25	Internal parameter system malfunction	Access to a non-existing instance	Most likely a bug in the firmware, check if there is a new firmware version available or contact the manufacturer.
26	Internal meta data system malfunction	-	Most likely a bug in the firmware, check if there is a new firmware version available or contact the manufacturer.
27	Parameter write or read wrong datatype function used	-	Will be thrown when trying to read or write the wrong datatype value from/to a parameter (e.g., when trying to get a floating-point value from an integer parameter).
28	Parameter write value out of range	-	Will be thrown when trying to write a value to a parameter that is out of its limits (e.g., when trying to write an integer number that is larger than the maximum a 32-bit integer can hold).
29	Parameter save to flash called from interrupt	-	Writing to flash from the Interrupt Service Routine (ISR) is not allowed and when attempted will result in this error.

Table 24: Power Supply Errors

#	Description	Error Condition	Further Information
30	Input voltage net too low	< 10.5V for TEC-1089/1090/1122/1123/1162/1163/1166/1167	Input voltage from the power supply is too low or unstable. Try increasing the supplied voltage to the controller. Please take care not to exceed the maximum input voltage of the device to avoid damaging the device. Also try limiting the number of devices on the same power supply or try swapping the power supply.
		< 4.8V for TEC-1092/1091/1161	

#	Description	Error Condition	Further Information
31	Input voltage net too high	> 27.0V for -SV Types	Input voltage from the power supply is too high or unstable. Try decreasing the supplied voltage to the controller.
		> 38.0V for -HV Types	
		> 14.0V for TEC-1092	
		> 25.5V for TEC-1091/1161	
32	Internal Medium Voltage power net too low	< 8.0V (HW Version Depending) ≥ HW v1.51 for TEC-1089/1090 ≥ HW v1.32 for TEC-1122/1123	May be related to the power supply and its settings. Can be thrown while powering on the controller when the supplied voltage is not immediately guaranteed. Try changing the power supply settings or try swapping out the power supply. If the measured value is constantly below the minimum (see "Medium Internal Supply" value in the "System" window), then it is very likely the controller is damaged.
		< 4.7V for TEC-1092/1091/1161/1162/1163/1166/1167	
33	Internal Medium Voltage power net too high	> 9V (HW Version Depending) ≥ HW v1.51 for TEC-1089/1090 ≥ HW v1.32 for TEC-1122/1123	May be related to the power supply and its settings. Can be thrown while powering on the controller when the supplied voltage is set too high. Try changing the power supply settings or try swapping out the power supply. If the measured value is constantly above the maximum (see "Medium Internal Supply" value in the "System" window), then it is very likely the controller is damaged.
		> 5.25V for TEC-1092/1091/1161/1162/1163/1166/1167	

#	Description	Error Condition	Further Information
36	Internal 3.3V power net too low	< 3.1V	May be related to the power supply and its settings. Try changing the power supply settings or try swapping out the power supply. If the measured value is constantly below the minimum value (see "3.3V Internal Supply" value in the "System" window), then it is very likely the controller is damaged.
37	Internal 3.3V power net too high	> 3.5V	May be related to the power supply and its settings. Try changing the power supply settings or try swapping out the power supply. If the measured value is constantly above the maximum value (see "3.3V Internal Supply" value in the "System" window), then it is very likely the controller is damaged.

Table 25: Flash Memory Errors

#	Description	Error Condition	Further Information
50	On-board flash failure	Write Timeout	Can happen when the write cycle limit of the flash (>= 100'000) is hit. It will not be possible to persist any new values on the flash once the limit has been hit.
51	On-board flash failure	Erase Timeout	Can happen when the write cycle limit of the flash (>= 100'000) is hit. It will not be possible to persist any new values on the flash once the limit has been hit.
52	On-board flash failure	Invalid Address	Can happen a value is tried to be written to an invalid or reserved address space on the flash. Is most likely a bug in the firmware, check if there is a new firmware version available or contact the manufacturer.

Table 26: Communication Error

#	Description	Error Condition	Further Information
53	UART Send buffer overflow error	An overflow occurred while trying to write a character to the Tx send buffer.	Is most likely a bug in the firmware, check if there is a new firmware version available or contact the manufacturer.
54	CANopen internal error	-	Internal error by the CANopen library. The CANopen error code is returned as Error Parameter.

Table 27: Device Temperature and Hardware Errors

#	Description	Error Condition	Further Information
60	Device running too hot	Check the datasheet of your device for the maximum device temperature specification.	Try to cool your device, e.g., by adding active cooling in the form of a fan or passive cooling using a heat sink.
61	Communication error with I/O hardware during factory test	-	This error can only happen during the internal hardware test performed by the manufacturer.
63	UART Temperature Sensor malfunction.	Cannot initialize the Device Temperature sensors or they deliver wrong values.	Is most likely a bug in the firmware, check if there is a new firmware version available or contact the manufacturer.

8.2.2 Error Numbers 100 - ... (Specific for TEC-Family devices)

Table 28: Power Output Errors

#	Description	Error Condition	Further Information
100	Overcurrent (positive), Driver CHx OUT+	> 'Current Error Threshold'	Check whether the actual output current is higher than the defined "Output Current Error Threshold" in the "Temperature Controller" window.
101	Overcurrent (negative), Driver CHx OUT+	> 'Current Error Threshold'	Check whether the actual output current is higher than the defined "Output Current Error Threshold" in the "Temperature Controller" window.
102	Overcurrent (positive), Driver CHx OUT-	> 'Current Error Threshold'	Check whether the actual output current is higher than the defined "Output Current Error Threshold" in the "Temperature Controller" window.
103	Overcurrent (negative), Driver CHx OUT-	> 'Current Error Threshold'	Check whether the actual output current is higher than the defined "Output Current Error Threshold" in the "Temperature Controller" window.
104	Overvoltage, Driver CHx OUT+	> 'Voltage Error Threshold'	Check whether the actual output voltage is higher than the defined "Output Voltage Error Threshold" in the "Temperature Controller" window.
105	Overvoltage, Driver CHx OUT-	> 'Voltage Error Threshold'	Check whether the actual output voltage is higher than the defined "Output Voltage Error Threshold" in the "Temperature Controller" window.
106	Residual current too high. The Current difference between OUT+ and OUT- is too big.	$ \text{OUT+} - \text{OUT-} > I_{\text{max}} * 0.1$	An isolation failure has been found. Check if there is a connection between OUT+ and OUT- to something else (e.g., ground) than your Peltier element or resistive heater.
107	Overall current monitoring, triggers fast switch off (within 10 μs)	Approximately 150% of the nominal maximal output current.	Check if there is a short circuit between OUT+ and OUT- or whether there is a short circuit on the Peltier element.

#	Description	Error Condition	Further Information
108	Output Stage saturation error. Check input current is sufficient and V_{out} not set too close to V_{in} . Try to reduce the "Current Limitation" in the "Operation" tab.	Output Stage is in saturation for more than 1ms. This time can be changed by a user setting.	Usually occurs when the controller wants to increase the output voltage but is unable to do so because the input voltage is too low. This can happen, among other things, if the output voltage limit ("Output Voltage Limitation") is set too close to the effective input voltage. Ideally, there would be a margin of 4 V, but less is usually also possible.
109	In case of parallel operation: The output current from channel 1 and channel 2 are too unequal.	If an unequal current is measured, the power stage tries to balance the currents. If this is not successful after some time, then it throws this error.	Make sure CH1 and CH2 are connected together with a Y-cable.
111	The connected load has a too low resistance in comparison to the input voltage	$> 2/3 * I_{max}$ before a stage goes fix to GND one 1 side.	Try increasing the load resistance. Reduce the input voltage and limit the current to $2/3 * I_{max}$.

Table 29: Current Measurement Errors

#	Description	Error Condition	Further Information
120	Offset during initialization of current monitor too high, Driver CHx OUT+	$>$ (Maximum Output Current of the Controller / 16)	-
121	Offset during initialization of current monitor too low, Driver CHx OUT+	$<$ -(Maximum Output Current of the Controller / 16)	-
122	Offset during initialization of current monitor too high, Driver CHx OUT-	$>$ (Maximum Output Current of the Controller / 16)	-
123	Offset during initialization of current monitor too low, Driver CHx OUT-	$<$ -(Maximum Output Current of the Controller / 16)	-

Table 30: HR Temperature Measurement Errors

#	Description	Error Condition	Further Information
130	HR Temperature Measurement Circuit Initialization failure	Wrong detected ready signal.	If this error occurs, it is very likely that an ADC on the controller is defective. If the error does not disappear after a reset/power cycle, please perform an ADC Self Check and send the results to the manufacturer for further instructions.
131	HR Temperature Measurement Circuit failure	Configuration read back failed.	If this error occurs, it is very likely that an ADC on the controller is defective. If the error does not disappear after a reset/power cycle, please perform an ADC Self Check and send the results to the manufacturer for further instructions.
132	External ADC supply voltage out of range	$-5\% < AVDD < +5\%$	If this error occurs, it is very likely that an ADC on the controller is defective. If the error does not disappear after a reset/power cycle, please perform an ADC Self Check and send the results to the manufacturer for further instructions.
133	23bit ADC raw value below safety margin	< 500000 (6%)	Check if there is a short circuit in the temperature measurement wiring (HR). If this input is not used set the "ADC Limit Errors" and "Temp. Limit Errors" parameters in the "HR Input x" window both to "None".
134	23bit ADC raw value above safety margin or the measured resistance is too high	$ADC > 8350000$ (99.5%) $R > 1M\Omega$	Check if there is an open circuit in the temperature measurement wiring (HR). If this input is not used set the "ADC Limit Errors" and "Temp. Limit Errors" parameters in the "HR Input x" window both to "None".
137	Measured HR temperature out of permitted range	$< \text{'Lower Error Threshold'}$	Check if the measured HR temperature is smaller than "Lower Threshold" in the "HR Input x" window.

138	Measured HR temperature out of permitted range	> 'Upper Error Threshold'	Check if the measured HR temperature is higher than "Upper Threshold" in the "HR Input x" window.
139	Change in measured HR temperature too fast (out-pacing thermal inertia)	> 'Max Change' while 20 succeeding cycles into the same direction.	Measured HR temperature changes too fast. Check if the measured object temperature changes faster than the "Max Change" in the "HR Input x" window.
150	HR Temperature Measurement Circuit failure (23bit ADC new ADC value timing error)	Ready signal is out of synchronization	Either the ADC is defective, or it is impaired in some way. Contact the manufacturer to open a new RMA case for your device if you wish to get it repaired.
151	HR Temperature Measurement Circuit failure	Several times the same ADC value read	This error usually occurs when the temperature sensor is not properly connected, or no sensor is connected whatsoever. Verify the wiring of your sensor with the datasheet of your controller.
152	HR Temperature Measurement Circuit failure	ADC Self Check failed. IRs out of range	Can only occur while performing an ADC Self Check and indicates damage on the ADC.
153	HR Temperature Measurement Circuit failure	ADC Self Check failed. VRef out of range	Can only occur while performing an ADC Self Check and indicates damage on the ADC.

Table 31: LR Temperature Measurement Errors

#	Description	Error Condition	Further Information
140	12bit ADC raw value below safety margin	< 40 (1%)	Check if there is a short circuit in the LR temperature measurement wiring. If the LR measurement should not be used set the option "Sink Source Selection" in the respective channel configuration popup on the main window to "Fixed" and set the "ADC Limit Errors" and "Temp. Limit Errors" parameters in the "LR Input x" window both to "None".
141	12bit ADC raw value above safety margin	> 4050 (99%)	Check if there is an open circuit (e.g., when no sensor is connected) in the LR temperature measurement wiring. If the LR measurement should not be used set the option "Sink Source Selection" in the respective channel configuration popup on the main window to "Fixed" and set the "ADC Limit Errors" and "Temp. Limit Errors" parameters in the "LR Input x" window both to "None".
142	Measured LR temperature too low	< 'Lower Error Threshold'	Check if the measured LR temperature is smaller than "Lower Threshold" in the "LR Input x" window.
143	Measured LR temperature too high	> 'Upper Error Threshold'	Check if the measured LR temperature is higher than "'Upper Threshold" in the "LR Input x" window.
144	Change in measured LR temperature too fast (outpacing thermal inertia)	> 'Max Temp Change' while 20 succeeding cycles into the same direction.	Check if the measured LR temperature changes faster than the "Max Change" in the "LR Input x" window.

Table 32: Autotune Errors

#	Description	Error Condition	Further Information
170	Auto Tune Progress Error	Less than 3% of progress advancement in 5 minutes for the fast model and 60 minutes for the slow model	<p>The progress of the auto tuning is determined upon several parameters. This error is generated when the process is too slow.</p> <p>Set the "Thermal Model Speed" to "Slow Model" to have longer time periods.</p> <p>Make sure your thermal model is stable before you start a new try.</p>
171	Auto tuning failures at three consecutive attempts	More than 40% discrepancy in temperature	<p>The tuning process executes several swing periods to determinate the results. This error is generated if values of these swing periods are too different. Do not change the thermal load during the tuning process.</p> <p>Make sure the thermal object is isolated from any changing air flows.</p>
172	Auto tuning failures at three consecutive attempts	More than 40% discrepancy in waveform period	<p>The tuning process executes several swing periods to determinate the results. This error is generated if values of these swing periods are too different. Do not change the thermal load during the tuning process.</p> <p>Make sure the thermal object is isolated from any changing air flows.</p>
173	The Temperature Controller is in its limitation or is not running.	Make sure the Temperature Controller is Running and the Temperature has equalized before you start the Auto Tuning	<p>Make sure that the TEC Controller's output stage is set to "ON", and that the TEC Controller's "Output Stage Input Selection" is set to "Temperature Controller".</p> <p>Make sure you use suitable default PID Settings.</p>

Table 33: Fan Control Errors

#	Description	Error Condition	Further Information
175	The Fan does not reach the desired rotation speed.	Fan PWM Signal is 100% and the reached Speed is < 60% of the nominal speed while 12s	Check if your Fan can reach the defined "100% Speed [rpm]" in the "Fan" window. If not, reduce the "100% Speed [rpm]" to a value, which your Fan can reach. Confirm whether the Fan might be broken.
176	The Fan does not rotate	Fan Speed = 0 and PWM Level > 35% while 10s	Check if the Fan wiring and GPIO configuration of the TEC Controller are correct. Confirm whether the Fan might be blocked or broken.

Table 34: Lookup Table Errors

#	Description	Error Condition	Further Information
180	Unknown Instruction	-	An instruction that is not supported by the firmware was found in the lookup table. See chapter 7.1.2 Instruction Set and Options for a list of available instructions.
181	Misuse of an Instruction	-	Check whether the Instructions used in your lookup table are in the correct order and whether the Field options you use are compatible with their respective Instructions.

Table 35: Various Errors

#	Description	Error Condition	Further Information
182	Temperature Stability not reached in specified time.	Check the "Max Time" value in the "Stability Indicator" box of the "Temperature Controller" window. Increase it if necessary or set it to 0 to disable this function.	"Max Time" is set too small or too high. Check if your PID Regulation is fine – use our default values, it works most of the time, even if it is a bit slow.
183	No package has been received within the specified Watchdog timeout time.	-	Check the defined Communication Watchdog "Timeout" value in the "Communication" window. Set it to 0 to disable the Watchdog.
184	Syntax Error in Display Format Argument String	-	See chapter 6.2.1.2 Parameter Syntax .
185	Display Format Argument String: Parameter ID not available. The Error parameter shows the parameter ID, which is not available.	-	Trying to show values from a "Parameter ID" which is not available. Check your "Display Format Argument String" in the "Display" window.
186	Display Format Argument String: Parameter Instance not available. The Error Instance shows the parameter Instance which is not available.	-	Trying to show values from a "Parameter Instance" which is not available on the controller. Check your "Display Format Argument String" in the "Display" window.
187	Configuration not supported	Some settings are not compatible with this device.	-
188	Reset required	Some essential settings are only applied during startup. Please reset the device.	See chapter 2.1.2 Reset the TEC Controller .

A Change History

Date of change	Version	Changed / Approved	Firmware Version	Change / Reason
30 July 2020	G	ML / HS	v5.00	<ul style="list-style-type: none"> • Add Changelog • Firmware Updates chapter adapted to FW v5.00 • Front Page: Remove TEC-1161-xA • Add TEC-1161 & NTC temperature configuration in chapter 3 • Incorrect hyperlinks fixed
30 July 2020	G	HS / ML	v5.00	<ul style="list-style-type: none"> • Added matching TEC-Controller Firmware Version to footnotes • Sentence rephrased and spelling error corrected in chapter 2.3
23 March 2021	H	XF / RS	v5.01	<ul style="list-style-type: none"> • Modified confusing sentence in chapter 7.1.1 (first bullet point) • Modified Display Kit section to feature all display kits
30 January 2023	I	ML / XF	v5.10	<ul style="list-style-type: none"> • Add: GPIO Function: Ramp • Add: Error 185, 186 (Display Format errors) • Add: GPIO Function "Fix 0" • Bug: Error 109: Text was wrong • Add: Hint that Ti can be set to 0s to disable the integral term • Add: CANopen related information • Add: VIN2 related information • Add: Error description for TEC-1162/1163/1166/1167 • Mod: Object Temperature Source Selection
27 March 2023	I	XF / ML	v5.10	<ul style="list-style-type: none"> • Add: Lookup Table Definitions in chapter 7.1.2 • Add: Further information column for errors in chapter 8.2
19 July 2023	J	ML / XF	>v5.10	<ul style="list-style-type: none"> • Mod: Error numbers 6, 8, 13-15 • Del: Parameter System Save to Flash Configuration (Save Data to Flash)

Date of change	Version	Changed / Approved	Firmware Version	Change / Reason
23 September 2024	J	XF / ML	v6.00	<ul style="list-style-type: none"> • Mod: Various adjustments based on replacement of TEC Service Software with TEC Configuration Software starting with firmware v6.00 • Mod: Generally replaced "Object Measurement" with "HR Input" naming • Mod: Generally replaced "Sink Measurement" with "LR Input" naming • Add: "Software Requirements" chapter • Add: "Reset the TEC Controller" chapter • Add: "Tooltips" chapter • Add: Descriptions of new Operating Modes • Add: "Upgrade Firmware from a Version below 6.00" chapter • Add: "Assignment of Measurement Inputs to Channels" chapter • Add: "Precautions" list in "PID Auto Tuning" chapter • Mod: "Charting and Data Logging" chapter adjusted based on changes in their revised implementations within the new software • Mod: The maximum amount of possible GPIOs has increased from 8 to 10 • Add: "HW Enable Toggle" GPIO function • Add: Error numbers 187, 188 • Fix: Error number 150 had the same error details as error 151, replaced with correct information • Del: Error number 110