

# User Manual – TEC Controller

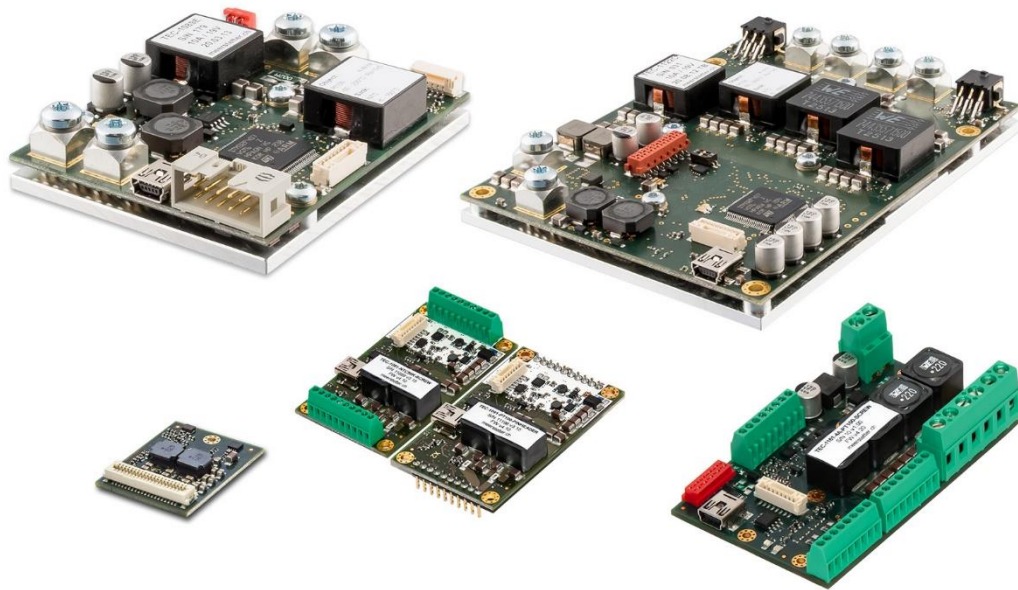

## TEC-Family:

TEC-1092  
TEC-1091

TEC-1089  
TEC-1090

TEC-1122  
TEC-1123  
TEC-1161-xA

# Index

- 1 Introduction.....4
  - 1.1 Important Documents .....4
  - 1.2 How to Contact Support.....4
- 2 Basic Functions .....5
  - 2.1 The Status Bar of TEC Service Software .....5
  - 2.2 Remote Control Options .....8
  - 2.3 Operating the Power Stage.....9
  - 2.4 Firmware Updates .....11
- 3 Temperature Measurement .....12
  - 3.1 Object Temperature Measurement .....13
  - 3.2 Heatsink Temperature Measurement.....18
- 4 Temperature Control.....19
  - 4.1 Theory of Operation.....19
  - 4.2 Control Modes .....20
  - 4.3 PID Auto Tuning (PID Parameter Optimization) .....21
  - 4.4 Two Channel & Parallel Mode Operation .....23
- 5 Charting and Data Logging .....24
  - 5.1 Charts.....24
  - 5.2 Monitor Data Logger .....26
  - 5.3 Real Time Data Logger.....27
- 6 External Hardware .....28
  - 6.1 GPIO1 – GPIO8 Control Signals.....28
  - 6.2 Display Kit (DPY-1113) and others .....34
- 7 Special Functions .....38
  - 7.1 Lookup Table Processing & Scripting .....38
  - 7.2 Parameter handling .....39
  - 7.3 Special Settings.....40
- 8 Appendix .....41
  - 8.1 Troubleshooting.....41
  - 8.2 Error Numbers, Instances and Parameters.....42

**Meerstetter Engineering GmbH**

Schulhausgasse 12  
CH-3113 Rubigen  
Switzerland

Phone: +41 31 529 21 00

Email: [contact@meerstetter.ch](mailto:contact@meerstetter.ch)

Meerstetter Engineering GmbH (ME) reserves the right to make changes without further notice to the product described herein. Information furnished by ME is believed to be accurate and reliable. However typical parameters can vary depending on the application and actual performance may vary over time. All operating parameters must be validated by the customer under actual application conditions.

Document 5216F

Release date: 14 July 2020

# 1 Introduction

This manual covers the functionality of the TEC-Family digital temperature controllers. If you use our TEC Controllers the first time, we recommend you watch first our tutorial videos or read the step by step guide document available on our website.

Most of the explanations in this document assume, that you use the “TEC Service Software”, but all the operations can also be done by your own application if you implement the functionality. Most of the commands are documented in our communication protocol documents.

If you cannot find the feature or setting you need, please do not hesitate to contact our support. We do also provide customized firmware solutions.

## 1.1 Important Documents

- [Datasheets](#)
  - Technical specifications
  - Temperature configurations and possible temperature measurement ranges
  - Ordering information
- [TEC-Family Communications Protocol](#)
  - Protocol specification
  - Commands, Parameters
  - Example Application and [APIs](#)
- [Temperature Sensor Cable Specifications](#)
  - Pinout
  - Temperature sensor assembly
- [Temperature Sensor Suggestions](#)
  - Description, part numbers and distributors for NTC, Pt100 and Pt1000 sensors
- [Tutorial Videos](#)
  - Learn more about the TEC Controller features and how to set up a cooling system
- [Application Notes](#)
  - Additional Information about different usages of our TEC Controllers

## 1.2 How to Contact Support

For optimal technical assistance we need the following information:

- Configuration file, exported while the error is present
  - Click “Export Config” in the footer
- Monitor History
  - Click “Maintenance tab” → “Monitor Data Logger” → activate Checkbox “Export all Monitor Values to CSV File (Debug)” → “Export Logged Monitor Data to CSV File”
- Screenshot of the “Chart” tab, if you have temperature control problems

Start the [TeamViewer software from our website](#) for a remote-control session. As soon as you start the tool we will recognize you, but please make sure to call or write us beforehand.

## 2 Basic Functions

### 2.1 The Status Bar of TEC Service Software

The bottom row of the software is always visible and shows the following information:

- Connection status
- Device status
  - Ready: Normal standby status (no errors). Output stage disabled
  - Run: Normal operating status (no errors). Output stage enabled
  - Error: Error occurred. Output stage disabled
  - Bootloader: Firmware is being updated
- Operating parameters for each channel
  - Temperature with stability indication
  - Current and voltage

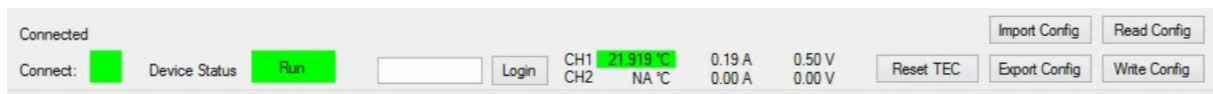

Figure 1. Status bar in the bottom row of the Service Software.

## 2.1.1 Status LEDs and Service Software Status

TEC-Family devices feature two status LEDs. In normal operation, the green LED is blinking.

In the case of any error occurring, the TEC Controller enters an error status and the red LED is lit. Power circuitry (output stage) is immediately deactivated for safety reasons. Control, monitoring and communication circuitry remains active. In case of software / configuration errors (i.e. not hardware faults), parameter can be reconfigured on the fly. The TEC Controller needs to be software-reset or power-cycled to clear the error status.

**Table 1. Status LED description.**

Green LED	Red LED	Signification
Blinking slowly	-	“Ready” status (no errors). TEC output stage disabled
Blinking fast	-	“Run” status (no errors). TEC output stage active
-	Static on	“Error” status. TEC output stage disabled
Static on	Static on	“Bootloader” status

When the Service Software is connected to a TEC Controller, its status is displayed in the bottom of the software window.

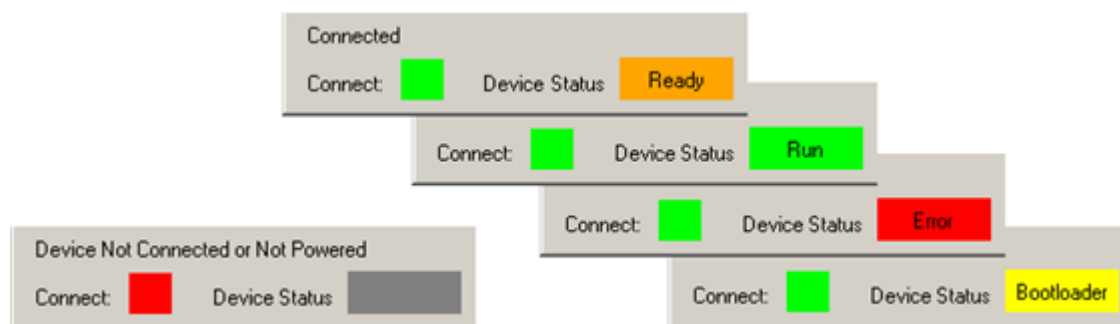

Figure 2. TEC Service Software color codes for connection and device status.

### Error Condition:

If the TEC Controller enters the error condition, please go to the Monitor tab, there you can find the error number and description on the right side of the window.

Alternatively, you can find a list of all errors here: [8.2 Error Numbers, Instances and Parameters](#)

## 2.1.2 Temperature Stability Indicator

For some applications temperature stability within a temperature range or the time for the stability is important.

When a TEC Controller output stage is operated as temperature controller, the background color of the temperature value in [Figure 1](#) is a visual indicator for stability:

- Green if the temperature is stable
- Amber if the temperature is not within the defined criteria
- Grey if the output stage isn't operated as a temperature controller or if the output stage is off

The Temperature Stability Criteria consists of a temperature range and time frame, defined in the "Object Temperature" tab. Stability is given if the temperature is

- inside the range defined in "Temperature Deviation"
- for a certain time (seconds) defined in "Min Time in Window".

An error is thrown if the object temperature is not stable within the time defined in "Max Stabilization Time". To disable this feature, set this parameter to 0.

## 2.1.3 Writing and Reading Device Parameters

Changed parameters are saved to the controller by clicking "Write Config" in the footer. Multiple parameter fields can be written at once. Be aware that also fields in tabs which are not displayed are written to the controller.

Parameters are read automatically when a connection to the controller is established.

## 2.1.4 Importing and Exporting .ini Configuration Files with TEC Service Software

TEC Controller device configurations sets can be exported as backup or for support purposes. They are device specific as they contain calibration data.

- Export
  - To save a configuration file on the PC, click on "Export Config" in the bottom right corner of the Service Software.
  - All actual values are stored. The values are useful for support and analysis.
- Import
  - To load a configuration file from the PC, click on "Import Config" in the Service Software.
  - By default, temperature measurement calibration data is only imported when the serial number in the configuration file matches the connected device's serial number. (This option can be disabled in the "Advance" tab at the bottom.)

## 2.2 Remote Control Options

This is an overview of the different remote-control options for the TEC Controllers. It's possible to configure, control and monitor the TEC Controllers using any Software which can communicate over an appropriate interface. In the Document "[TEC-Family MeCom Communication Protocol 5136](#)" a list of the software options available from us can be found.

Generally, all parameters available in the Service Software can be read and written by other means using the communication protocol.

More information is available in the following documents:

- [TEC-Family MeCom Communication Protocol 5136](#)
- [MeComAPI](#)
- [TEC LabVIEW Control Software Notes 5200](#)

Digital general purpose I/O

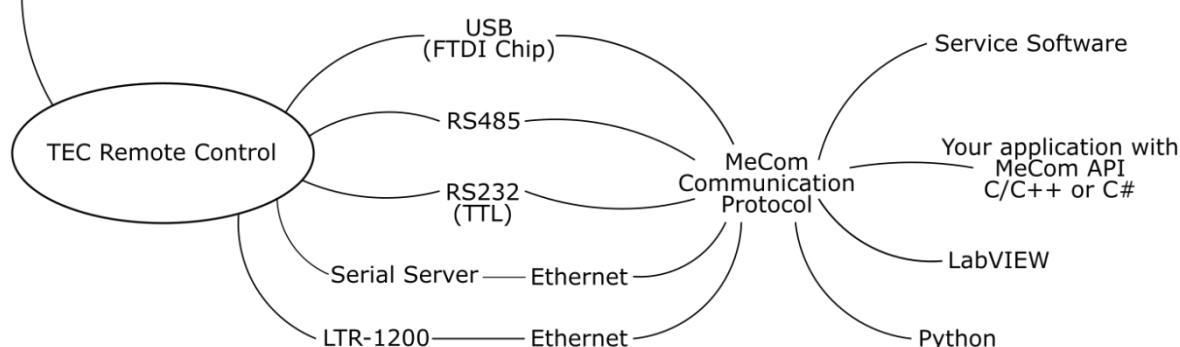

Figure 3:TEC Controller remote control options

### 2.2.1 Serial Communication

Serial communication is used to send data from a host to a TEC Controller and receive data from the controller, respectively. The following physical interfaces are supported:

- USB
- RS485 (Check our [TEC Application Note - RS485 Interface](#))
- RS232 TTL<sup>1</sup>

Communication using the Service Software and RS485 is only possible using a USB–RS485 adapter or an ethernet serial server, since the Service Software only connects to FTDI<sup>2</sup> chips or TCP port 50'000.

#### 2.2.1.1 Addressing Specific TEC Controllers

Assign a unique "Device Address" to the TEC Controller if multiple TEC Controllers are operated on the same platform bus, e.g., when mounted in a LTR-1200 rack enclosure or when the Service Software should connect to a specific device. The "Device Address" can be set on the Operation tab when the TEC Service Software has already connected to the device. You can then advise the TEC Service Software to use a specific device address to communicate. For this open the "Maintenance" tab and search for "Service Communication Settings". For more application arguments, check our communication protocol document. all TEC Controllers have a 1-unit load receiver input impedance, allowing up to 32 transceivers on the bus.

<sup>1</sup> Not available on all TEC Controllers

<sup>2</sup> One option is the [USB RS485 converter cable from FTDI Chip](#), available in different lengths.

## 2.2.2 Ethernet Communication

Communication over Ethernet is possible by integrating up to four TEC Controllers into a [LTR-1200 19-inch rack enclosure](#), which offers an Ethernet connection. This allows the integration into a standard 19-inch rack or it can be used as table-top instrument.

It is also possible to use a standard Serial Server to connect all our devices to an Ethernet interface. We have tested devices from Lantronix (ex. XPort or UDS1100) and Moxa (ex. NPort 5130). Please ask us for application examples.

## 2.3 Operating the Power Stage

### 2.3.1 Theory of operation

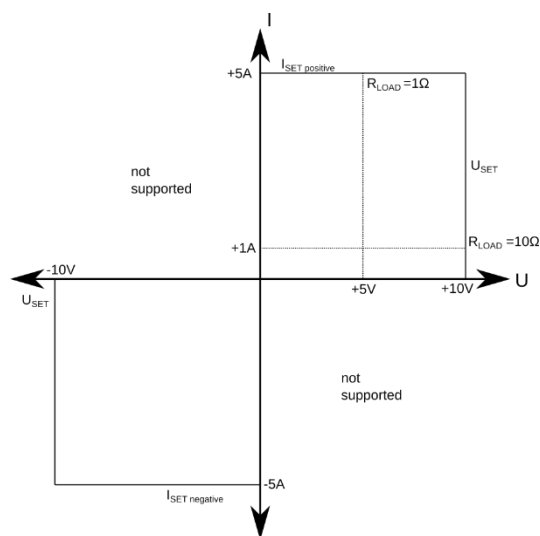

The output stage controller outputs either the desired voltage or the desired current, depending on which value first runs in its limitation. It works in a way like a lab power supply with current and voltage limitation.

The output stage works in the two sourcing quadrants, shown on the left side. The polarity is defined by the  $I_{SET}$  value. This means  $U_{SET}$  is always entered positive and the  $I_{SET}$  can be set positively or negatively.

For this example, the settings are set to:  
Input Selection: Static Current / Voltage  
Set Current: 5A  
Set Voltage: 10V

In one condition a 100ohm Resistor is connected. In this case the output stage reaches the 10V limitation before the 5A limitation is reached. This means the output stage outputs 10V at 1A.

In the other condition, a 10ohm Resistor is connected. In this case the output stage reaches first the 5A limitation. This means the output stage outputs 5V at 5A.

## 2.3.2 Output Stage Controller Settings

The output stage of a channel can be controlled by three sources:

- “Static Current/Voltage”: Values are read from the non-volatile memory (flash).
- “Live Current/Voltage”: The current and voltage values are read from the volatile memory (RAM), which can be continuously updated by remote-control.
- “Temperature Controller”: The current and voltage values are calculated by the controller as a function of temperature and other information.

The channel’s output is activated by “CHx Output Stage Enable”. “Output Enable” settings are saved to the flash and remain active after a device power cycle. or reset.

- In “Static OFF” mode, the enable status is set to disabled
- In “Static ON” mode, the enable status is set to enabled
- In “Live OFF/ON” mode, the enable status is read from the RAM. It returns to default status OFF after a device power cycle or reset.
- In “HW Enable” mode, the enable status is read from a user-defined GPIO. Please refer to chapter [6.1 GPIO1- GPIO8 Control Signals](#) for detailed information.

The “CHx Output Stage Static Current/Voltage Control Values” are read when the TEC Controller channel is used as “Static Current/Voltage”:

- The sign of the “Set Current” parameter determines the polarity of both the current and voltage.
- “Set Voltage” only accepts positive values.

The “CHx Output Stage Limits” are safety settings that limit the TEC Controller’s output power to protect the connected Peltier elements or other components.

Both the static and live settings can be configured on the fly by remote control. The Service Software does not permit to write live parameters. Refer to the document “[TEC-Family MeCom Communication Protocol 5136](#)” for more information about bus controlled live RAM parameters.

## 2.4 Firmware Updates

You can [download firmware \(contained in the software package\)](#) from our website and update TEC Controllers using the Service Software.

The Service Software and the TEC Controller Firmware are strongly related. Only when a Service Software and a TEC Controller Firmware with a matching Version Number are used full functionality can be guaranteed. However, it is usually possible to connect to an old TEC Controller Firmware with a new Service Software and vice versa. Functionality will be limited, but firmware updates are possible.

Matching version numbers: All our publicized Software have a version like this “vX.YZ”. It is important that at least X and Y is matching. Z may be different.

Follow these steps to update devices:

- Read the [TEC Controllers Software Release Notes](#)
- Backup the current configuration. This is important because it is possible that the current configuration will be lost during the update.
- In the tab “Maintenance” click on “Load Hex File” in the box “Device Boot Loader”.
- Choose the new .hex file, open it and then click “Update Device”.
- The TEC Controller will reboot once the update completes.
- You can check the firmware version in the tab “Monitor”.
- Re-import the before exported .ini file (if necessary).
- Fill missing parameter values into new parameter fields (if applicable).

### 3 Temperature Measurement

This chapter covers the “Object Temperature”, “Sink Temperature” and “Advanced” → “Temperature Conversion” and “Temperature Measurement” tabs.

Every TEC Controller channel features two temperature sensor measurement inputs used for temperature control of some object:

- The primary input (23-bit ADC) measures the object temperature.
- The auxiliary input (12-bit ADC) measures the heatsink temperature and is optionally used.

The TEC Controller supports two types of temperature sensors: passive resistance temperature detectors (RTD), also known as thermistors, and voltage output temperature sensors. The passive resistance temperature sensor (RTD) has an accurate resistance per temperature relationship. Hence, to measure the temperature of some object, a sensor is fixed to it and the TEC Controller determines the resistance of the sensor or measures the output voltage, respectively.

## 3.1 Object Temperature Measurement

As a user you define the temperature working range of the object and you choose a sensor type. The supported sensor types for the primary input are the *voltage output sensors* as well as the following *RTDs*:

- NTC sensors (negative temperature coefficient, e.g., NTC10k sensors)
- Platinum sensors Pt100 or Pt1000 (positive temperature coefficient)

The TEC Controller has an onboard reference resistor  $R_S$  which is used by the measurement circuitry. This reference resistor shown in [Table 2](#) is defined as *sensor configuration* within the *hardware configuration* upon ordering and defines the possible temperature measurement range. In case of NTC temperature sensors,  $R_S$  also equals the highest resistance of the RTD, measurable by the TEC Controller.

**Table 2. Default configuration parameters for RTD temperature sensors.**

Device Type	Sensor Configuration	$R_S$ (k $\Omega$ )	$R_P$ (k $\Omega$ )
TEC-1089, TEC-1090, TEC-1122, TEC-1123	PT100	1.5	$\infty$
	PT1000	3.6	$\infty$
	NTC18K	18	$\infty$
	NTC39K	39	$\infty$
	NTC56K	56	$\infty$
	NTC1M	39	39
	VIN1	Diode <sup>3</sup>	
TEC-1091, TEC-1092	PT100	1.5	$\infty$
	PT1000	3.6	$\infty$
	NTC56K	56	$\infty$
	NTC1M	39	39
	VIN1	Diode <sup>3</sup>	

Refer to the TEC Controller datasheets for wiring diagrams for sensors and temperature measurement ranges.

### 3.1.1 NTC Sensors

#### 3.1.1.1 Example NTC Configuration

This example visualizes the relationship between temperature sensor type and sensor configuration.

As an example, we choose a TEC-1091 with an NTC56K sensor *configuration*. As temperature sensor (*type*) we select a NTC  $B_{25/100}=3988K$   $R_{25}=10k$  thermistor. The first value describes the temperature-resistance relationship and the second value indicates, that the sensor has a resistance of 10 k $\Omega$  at 25 °C.

According to the TEC-1091 datasheet, it's possible to measure a sensor resistance up to 55742  $\Omega$  for the NTC56K configuration, what corresponds to a temperature of -10.1 °C. The lowest possible resistance is 105  $\Omega$ , what corresponds to 176 °C.

---

<sup>3</sup> In case of voltage output temperature sensors,  $R_S$  is a Schottky Diode

### 3.1.1.2 Configuration of NTC Sensors

In case of an NTC sensor the temperature to resistance characteristics need to be entered manually by the user.

For each NTC temperature acquisition channel choose three temperatures (lower, middle and upper) spanning the measurement range to be covered. Look up their corresponding resistances in your sensor's data sheet. Three temperature-resistance pairs are needed to model a characteristic temperature-resistance curve using the Steinhart–Hart equation<sup>4</sup>

$$\frac{1}{T} = A + B \ln(R) + C(\ln(R))^3,$$

where T is the temperature (kelvin), R is the resistance (ohms), A, B, and C are the Steinhart–Hart coefficients.

Enter the three value pairs in the tab “Advanced” → “Temperature Conversion” in the field “CHx Object NTC Sensor Characteristics”.

This curve will be most precise for small ranges (lower point to upper point) that are centered about a working point / nominal temperature (middle point).

### 3.1.2 Pt100 / Pt1000 Sensors

Pt100 and Pt1000 temperature probe characteristics according to DIN EN 60751 are device internally stored and the user does not need to configure anything in the Service Software for the temperature measurement.

---

<sup>4</sup> [More information about the Steinhart–Hart equation on Wikipedia.](#)

### 3.1.3 Voltage Output Sensors

The TEC Controller can use a Linear Voltage Output Temperature Sensor to measure the Object Temperature. The characteristics of the sensor have to be entered manually by the user.

The values for Reference Temp, Reference Voltage and Temperature Slope are needed, they can be found in the datasheet of the sensor. Enter the three values in the tab "Advanced" → "Temperature Conversion" in the field "CHx Object Voltage to Temperature Conversion".

In the Document [TEC Application Note VIN1](#) Information about how to connect the Sensors to the TEC Controller can be found. The Voltage Measurement Range of each TEC Controller is listed in the corresponding datasheet.

### 3.1.4 Changing the Measurement Configuration

In case you would like to change the temperature sensor configuration of the primary input (as an example from PT100 to NTC1M), hardware modifications and configuration changes by software are necessary.

The configurations changes can be made by yourself, please [contact us](#), if you don't want to change the configuration by yourself. We recommend that the changes are made by us since we can guarantee a properly performed conversion and we can recalibrate the TEC Controller.

Please follow the instructions

- Replace the temperature reference resistor  $R_s$ .<sup>5</sup> The requirements for this resistor are: 0.1% tolerance, 5 ppm/°C temp. coefficient, 100 mW power rating, 0805 footprint. In the case of an NTC1M configuration, use a 39 kΩ resistor according to [Table 2](#).
- Only in case of the NTC1M configuration solder the resistor  $R_p$  parallel to the sensor input. Use the same resistor type as  $R_s$ .
- If the change is from four-wire measurement<sup>6</sup> (Pt100 and Pt1000) to two-wire measurement (NTC), then add jumpers to the measurement input. Remove the jumpers if the change is from two wires to four wires. The position is shown in the section *Pin Configuration* of the corresponding datasheet for the TEC Controller. Please note that the TEC-1092 exclusively works with four-wire measurement.
- Perform the following changes in the Service Software. (Please note that the sensor type NTC1M is only supported starting from Service Software version 2.70.)
  - Choose the option NTC1M in tab "Advanced" → "Temperature Measurement", Hardware depending Default Settings
  - Click "Load Settings".
  - Click "Write Config".
  - Click "Reset TEC".

Now you can check the object temperature measurement limits in the "Object Temperature" tab.

CH1 Object Temperature Measurement Limits		
Sensor Type:	Highest Voltage [V]	NA
NTC	Lowest Voltage [V]	NA
	Lowest Resistance [Ω]	73
	Highest Resistance [Ω]	1000000
	Temperature at lowest ADC [°C]	194.2
	Temperature at highest ADC [°C]	-55.5

Figure 4. New temperature measurement limits for NTC1M configuration of a TEC-1091.

In case a voltage output sensor replaces another sensor type, follow these steps:

- Jumpers at the measurement inputs need to be removed.
- Replace  $R_s$  by a Schottky diode.<sup>7</sup>

<sup>5</sup> Refer to the datasheet for the position of  $R_s$ . Possible choices for  $R_s$  are:

1.5 kΩ: WELWYN PCF0805-13-1K5-B-T1

3.6 kΩ: WELWYN PCF0805-13-3K6-B-T1

18 kΩ: WELWYN PCF0805-13-18K-B-T1

39 kΩ: WELWYN PCF0805-13-39K-B-T1

56 kΩ: WELWYN PCF0805-13-56K-B-T1

<sup>6</sup> Either two or four wires are used to connect the sensor, depending on the type. See TEC Controller datasheets for wiring. [More information about four-wire measurement on Wikipedia.](#)

<sup>7</sup> A possible choice is Toshiba CUS520,H3F (The voltage drop should be in the range of 0.1V to around 0.3V)

- Load the option VIN1 in the tab “Advanced” → “Hardware depending Default Settings”.
  - Click “Load Settings”
  - Click “Write Config”
  - Click “Reset TEC”
- Enter the three values in the tab “Advanced” → “Temperature Conversion” in the field “CHx Object Voltage to Temperature Conversion”.

### 3.1.5 Temperature Measurement Behavior

The behavior of the object temperature measurement can be configured in the tab “Advanced” → “Misc” in the box “CHx Actual Object Temperature”.

**Table 3. Parameter “Observe Mode”**

Option	Options and Description
Automatic	Default setting. Temperature monitoring is enabled for “Temperature Controller” mode
Disabled	Temperature monitoring is disabled for all CHx output stage control modes. No errors are generated when limits (→ error thresholds and internal ADC limits) are reached
Enabled	Temperature monitoring is enabled for all CHx output stage control modes

**Table 4. Parameter “Control Speed”**

Option	Options and Description
10Hz	Default setting. 10 Hz control and measurement frequency
80Hz/90Hz	90 Hz control and measurement frequency for TEC-1092 and 80 Hz for others
1Hz	1 Hz control and measurement frequency

**Table 5. Parameter “Source Selection”**

Option	Options and Description
Internal	Default setting. The onboard temperature measurement circuit is being used
External	The temperature can be fed over a data interface
CH2	Channel 1 takes the temperature from channel 2

### 3.1.6 Analog-to-Digital Converter Self-Check Function

It is possible that a damaged analog-to-digital converter (ADC) delivers incorrect temperature measurement results, which under certain circumstances remain undetected. To resolve this issue an ADC self-check function has been added. This function must be manually activated by the user or can be configured to be periodically executed with a user defined interval. When configured to run periodically, the first measurement is performed 10 seconds after startup. It is not recommended to run the periodic check in time intervals of less than 10 seconds.

While the ADC self-check function is running the temperature measurement results are not updated, so care must be taken to not run the self-test function while critical operating conditions are present or during autotuning. A self-check takes approximately 300ms.

The test function measures the supply voltage of the ADC as well as the current through the reference resistor and the voltage at the voltage reference input. If one of those values is out of range an error is thrown. The current measurement error can be disabled by setting the parameter "Error on IRs fail" to No.

The results of all measurements are stored and can be read for further evaluation.

It is not recommended to use the ADC self-check function when a reference resistor larger than 46k $\Omega$  is used as the results might be unreliable. Because of hardware differences, the sensor current cannot be measured when a voltage output sensor is used (-VIN1 version). In this case, only the reference voltage is measured and checked.

To start a check the parameter "Trigger Self Check" must be set to 1. After the check has finished, this value is automatically reset to 0. Writing a 0 does not cancel the test. To enable the periodic check the parameter "Periodic Check" has to be set to the required period in seconds. If the value is 0 no periodic check is performed.

The ADC self-check function can be configured in the Tab "Advanced" → "ADS Self Check".

## 3.2 Heatsink Temperature Measurement

The auxiliary heatsink temperature input can only accommodate NTC sensors. This input is less configurable and uses on the MCU-integrated 12bit ADC. The circuit's reference resistor  $R_V$  is factory-set to 5.6 k $\Omega$ .

Heat sink measurement improves the performance of the integrated power optimization routine, but is optional. By default, a fixed temperature value of 25 °C is used. Monitoring can be enabled in the "Sink Temperature Tab" by setting "Sink Temperature Selection" to "External".

## 4 Temperature Control

This chapter covers the “Temperature Control” tab.

### 4.1 Theory of Operation

The following part is a short description of the temperature control mechanism in the TEC Controller.

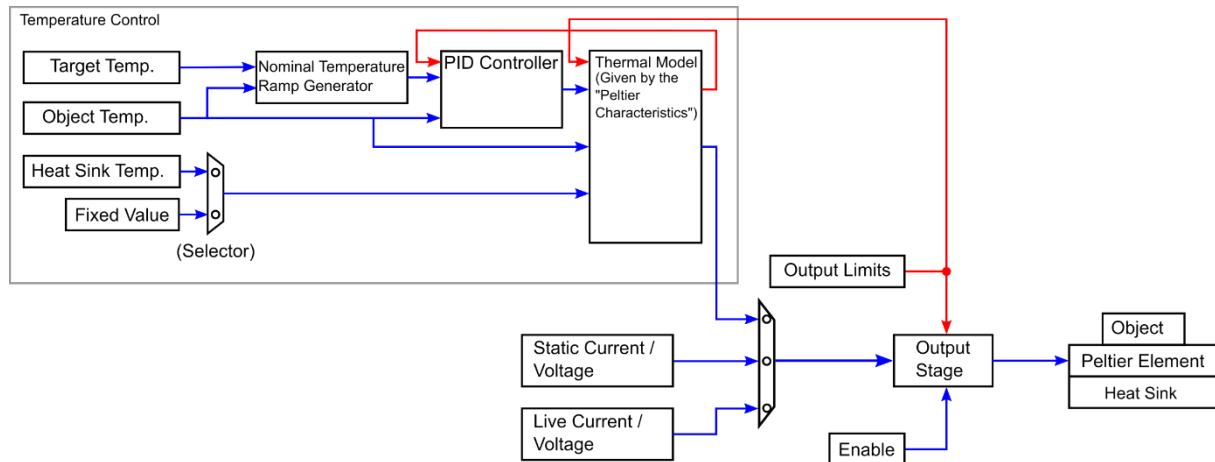

Figure 5. Temperature control functional overview.

- The TEC Controller measures periodically the object temperature and the temperature of the heat sink (optional) using temperature sensors. The temperature measurement is also active when the temperature controller is not.
- The target temperature is the setpoint for the PID controller.
- The temperature controller calculates the needed output power based on the target temperature, heat sink temperature and actual object temperature. It's possible to use a fixed value for the heat sink temperature (default setting).
- The output stage has three possible input parameters, either the value from the temperature controller, a static current and voltage or a live current and voltage.
- To keep the output stage in boundaries, output limits are set.
- The output stage is enabled and disabled by the enable parameter.
- Finally, the output stage powers the Peltier element.

#### 4.1.1 PID Control Parameters

- The proportional term  $K_p$  defines the portion [%] of normalized cooling/heating power that can be used to correct the difference [°C] between actual and nominal temperature. Assuming the temperature difference between actual and nominal is 2°C and  $K_p$  is set to 15%/°C, then the output will feed 30% power to the Peltier element.
- The integral term  $T_i$  defines the reset time [s] the regulator is allowed to take for correcting a given control deviation. The effect of  $T_i$  is weak for large values and strong for small values.
- The derivative term  $T_d$  opposes changes in control deviation, weighed by unit time [s]. The dampening effect of  $T_d$  increases with larger values. By default, the D component is bypassed (0s).
- The value “D Part Damping PT1” is damping the resulting value of the derivative term. It may be useful for very slow thermal models which result in high  $T_d$  times.

The suggested PID values are starting values that proved to work reasonably well at factory. At a later stage, you can optimize them for your application and system. This can be done manually or by using the auto tuning function in the Service Software.

### 4.1.2 Temperature Ramp

For certain thermal masses, the systems response to cooling and heating power may be slow and thus reaching thermal stability takes some time. On power-up large changes from an initial to a target temperature may be required. To minimize the overall time to reach thermal stability, the sudden jump in temperature is replaced by a generated three-part ramp.

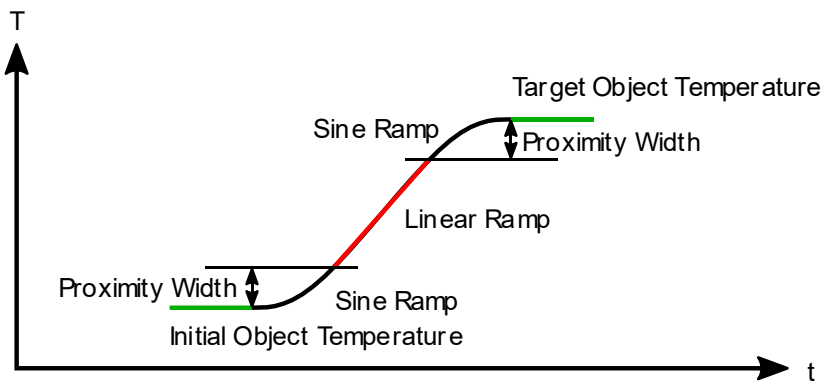

Figure 6. Temperature vs time change from an initial temperature to a target temperature, showing the three-part ramp.

First the nominal temperature is smoothly guided away from the starting value by a sine-shaped curve. After leaving the “Proximity Width” the temperature follows the faster, linear ramp—the “Coarse Temp Ramp”—at the maximum possible rate. Once again within the “Proximity Width”, the nominal temperature follows again a sine-shaped curve towards the target temperature. Using this ramping scheme, over- and undershoots in respect to the target temperature will be minimized and the final temperature is stabilized more quickly.

If a Linear Ramp without the sine shaped curves is required, the Proximity width can be set to 0.

It is unlikely that your system can follow the default “Coarse Temp Ramp” slope of 1 °C/s. This initial setting allows the user to get a feeling for the system's thermal inertia, and it permits observation of the nominal temperature trace in the graph.

Nominal temperature ramping allows the usage of more aggressive PID vales, typically required to properly react to external disturbances. Please note that the ramping and PID parameter sets are independent.

## 4.2 Control Modes

The TEC Controller supports the following three control modes, available in the field “CH1 Modelization for Thermal Power Control”:

- “Peltier, Full Control”: The Peltier element heats and cools, powered by the bipolar current.
- “Peltier, Heat only – Cool only”: The TEC Controller tries to keep the temperature between the “CHx Peltier, Heat Only – Cool Only Boundaries”. If the actual temperature is somewhere between these boundaries, the TEC Controller does not power the Peltier element.
- “Resistor, Heat only”: If a resistive heater is used, only heating is possible.

Depending on what you choose, either “CH1 Peltier Characteristics” or “CH1 Resistor Characteristics” parameters will be implemented (from either of the two group boxes underneath).

## 4.3 PID Auto Tuning (PID Parameter Optimization)

The “Auto Tuning” tab in the Service Software provides a powerful tool for system optimization. The results are optimized PID controller and ramping parameter sets. (See [4.1 Theory of Operation](#))

Follow these steps to optimize your system:

- The object temperature measurement should work reliable, prior to using the auto tuning function. This means that the correct temperature is measured and the fluctuation of the temperature value is small (i.e., < 5 mK).
- The Peltier element is connected with the correct polarity.
- Peltier characteristics (tab “Temperature Control”) must be set correctly according to the Peltier element’s datasheet.
- Set limits for current and voltage in the “Operation” tab.
- Make sure that the output stage is not running in its voltage limitation.
- Set the temperature limits in the “Object Temperature” tab, to avoid damage of anything in contact with the Peltier element.
- Set the desired object target temperature. If you will use multiple target temperatures, use the highest one. This leads to more reliable PID values in most cases.
- The channel to be optimized must already be successfully operating in the mode “Temperature Controller”. This means that the target temperature is reached with the standard PID settings ( $K_p = 10$ ;  $T_i = 300$ ;  $T_d = 0$ ).
- Before you start the auto tuning process, it’s recommended to note the currently used “CH1 Temperature Controller PID Values” and the parameters in the field “CHx Nominal Temperature” or to export the device configuration.
- During the optimization process, no other heating or cooling source other than the driven Peltier element must be active, to not disturb the process.
- Enable the temperature controller by setting the option “Output Enable” to “Static ON”.
- Wait until the target temperature is reached and the temperature has equalized.
- Select the TEC instance (channel) you want to optimize.
- Select the “Thermal Model Speed”:
  - “Fast Model”: Use this setting if you have only a small thermal load and the target temperature is usually reached within a minute. Always start with this setting.
  - “Slow Model”: Use this setting if you have a huge thermal load and the target temperature is usually reached within some minutes.
- Now the status indicator reads “Idle. Press Start to Tune!”. Press the “Start” button.
- The TEC Controller initiates a cooling-heating pattern that will reveal specific system information. The progress of the auto tuning procedure is indicated by the advancing status bar. You can observe the applied current patterns and resulting temperature variations in the “Chart” tab.
- Upon “Success. Tuning Complete!” the TEC Controller will continue regulating the temperature.
- Finally, the results of the optimization are displayed in the field “Tuning Results”. You can accept and use the new parameters by clicking “Write Auto Tuning Results to TEC”.

### 4.3.1 Trouble Shooting and Enhancements

Table 6. Possible reasons and possible solutions for common problems during auto tuning.

Problems	Possible Reasons	Possible Solutions
There is too much noise on the current output.	Your thermal model is very slow. Therefore, large Ti and Td times are calculated for the PID controller. High Td times result in a very big amplification of every small temperature difference or noise.	Set the "Thermal Model Speed" to "Slow Model" and start the auto tuning process again.
		Check "Use Slow PI Values" and click on "Write Auto Tuning Results to TEC". These values run without differential part of the PID controller.
		Go to "Temperature Control" tab and set "D Part Damping PT1" to a lower value. (Too low values will result in a worse temperature control behavior)
It takes too long until the desired target temperature is reached.  The nominal temperature ramp is too slow.  The TEC Controller is not providing the max. current to the Peltier element.	After auto tuning, the "Nominal Temperature Ramp" settings ("Coarse Temp Ramp" and "Proximity Width") are taken from auto tuning recommendations. These recommended values are intentionally slow values. The target is to prevent a temperature overshoot. Therefore, the PID controller must always be able to follow the nominal temperature ramp.	You may set "Coarse Temp Ramp" in the "Temperature Control" tab to a higher value. This will result in a faster nominal temperature ramp.  You may set the Setting "Proximity Width" to a lower value.
Error 170: Less than xx% of progress advancement in xx minutes.	The progress of the auto tuning is determined upon several parameters. This error is generated when the process is too slow.	Set "Thermal Model Speed" to "Slow Model" to have longer time periods.
		Let your thermal system cool down between two tuning attempts. Disable the power source to the Peltier element for several minutes.
Error 171 / 172: Auto tuning fails at three consecutive attempts due to more than 40% discrepancy in temperature / time.	The tuning process executes several swing periods to determinate the results. This error is generated, if values of these swing periods are too different.	Do not change the thermal load during the tuning process.
		Make sure the thermal object is isolated from any changing air flows.
Error 173: Auto Tuning detects that the PID temperature controller is in limitation.	TEC Controller is not Running in Temperature Controller Mode.	Make sure that the TEC Controller's output stage is "Static ON" and that the TEC Controller's "Output Stage Control Input" is set to "Temperature Controller".
	The Target Temperature has not been reached. The Temperature Controller is running in its output limitation.	Make sure you use suitable default PID Settings. These are described on the Service Software tab "Auto Tuning". Please read this description. Make sure the target temperature has been reached and equalized before you start the auto tuning process.

## 4.4 Two Channel & Parallel Mode Operation

TEC Controllers having two channels can operate them independently or in a combination. In the tab “Operation” the “General Operating Mode” can be set to the following options:

- Single (Independent): This is the default setting. Each channel uses its own temperature measurement and output stage.
- Parallel (CH1 → CH2); Individual Loads: The output current and output voltage values of channel 2 are set to the ones currently active for channel 1. The “CH1 Output Stage Enable” status is also valid for both channels. However, the output stage limits defined for each individual channel remain independent.

In practice, this means that the CH2 output stage will follow the values defined by the selected “CH1 Output Stage Control Input”—if it satisfies its own limits.

- Parallel (CH1 → CH2); Common Load: This mode allows current doubling. The outputs of the two channels are connected to one common load. If CH1 is working as “Temperature Controller”, the PID controller is aware it can dispose twice the nominal current, to which each channel will provide an equal amount. The CH1 + CH2 total output current is indicated in “Parallel Output Stage Monitoring (Common Load)” in the “Monitor” tab.

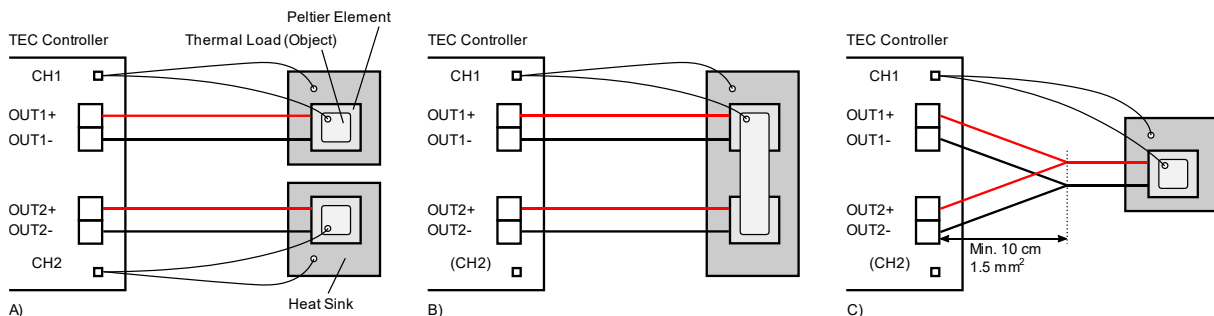

Figure 7. TEC Controller with temperature measurement inputs and output channels. Thermal load mounted on a Peltier element, mounted on a heat sink. A) Single (independent) mode. B) Parallel; Individual Loads mode C) Parallel; Common Load mode

## 5 Charting and Data Logging

### 5.1 Charts

#### 5.1.1 Chart

The tab “Chart” offers a convenient way of mid-term system characterization, e.g. for observing stability, or for optimizing PID control or nominal temperature ramping parameters.

Object temperature(s) and their nominal values (thin lines) are shown in the top panel, output current(s) and PID control variable magnitude(s) are shown in the bottom panel.

To display the full recording, since the start of the Service Software, click on the small clock symbol on the left side of the time scroll bar. (See [Figure 8](#))

## 5.1.2 Fast Chart

When a TEC Controller in combination with a small thermal load (e.g. a sensor) is used, the object temperature may change quickly. To examine the behavior of a fast-changing system, the Service Software features a DSO-like “fast chart”.

- Compared to the normal chart, the fast chart has a higher temporal resolution and records the object temperature in a maximum time frame of 10 seconds when using 80/90Hz control rate.
- The sampling rate for both channels in the chart depends on the setting “CH1 Actual Object Temperature Control Speed” (see 3.1.5 Temperature Measurement Behavior for more information).
- Pressing the “Load Data” button on the right side displays the data recorded in the last 10 seconds.



Figure 8. "Fast Chart" tab with panels for the object temperature (top) and output current / PID control variables (bottom).

## 5.2 Monitor Data Logger

For external plotting and data analysis, logged data can be exported to a .csv file, in the "Maintenance" tab in the box "Monitor Data Logger".

- Each log entry is time stamped.
- At relaunch of the software the log is erased and the log interval is set to the smallest value of 1 s.
- The graph recording time at a fixed rate is limited to 6 h.
- The general data logging duration is not limited. It depends on the available RAM on the PC and the logging interval.
- For critical long term monitoring we recommend exporting the log regularly and to relaunch the Service Software occasionally (e.g., every couple of days).
- The export of the logged data contains:
  - All data displayed in the tab "Chart" (object temperature, actual output current, PID control variable).
  - Sink temperature, target object temperature, (ramp) nominal temperature, thermal power model current and actual output voltage.
  - System values driver input voltage and device temperature.

## 5.3 Real Time Data Logger

Real time data logging to .csv files is possible, starting from Service Software version 3.00.

- Data is transferred in a kind of stream from the TEC Controller to the Service Software.
- Every temperature measurement sample measured and used to control the temperature is exported to the .csv file and marked with a time stamp.
- The logging interval is defined by the “Control Speed” defined in the tab “Misc” (see [Table 4. Parameter “Control Speed”](#)).

Some adjustments are necessary after the export due to the lack of formatting options in .csv files:

1. Open the exported .csv file.
2. Select the field C2.
3. Double-click on the square in the bottom right corner → the column is filled by values.
4. Copy your desired format from L1, e.g., “TT.MM.JJ hh:mm:ss.000”, the other one for users with a comma as decimal separator adjusted operating systems.
5. Select the entire column C by clicking on the column’s header.
6. Go to the formatting options by right-clicking on the column and selecting “Format Cells...”.
7. Choose the category “Custom”, paste the format copied prior and click OK → the time in the column C is now displayed in millisecond resolution.
8. Analyze the data by using calculations and adding diagrams.
9. Save the log as Excel file.

If the connection to the TEC Controller is lost during logging, entries containing the text “Connection Lost” will be saved to the .csv file.

## 6 External Hardware

### 6.1 GPIO1 – GPIO8 Control Signals

The GPIO1–GPIO4 control signals are available on every TEC Controller model and can be used for general purpose I/O (GPIO) or for predefined functions. The functions described in [Table 7](#) can be independently assigned to the GPIO signals in the “Advanced” → “GPIO General” tab. Many functions are separately available for both channels. For those functions, the corresponding channel can be chosen in the “Advanced” → “GPIO General” tab as well. For the functions which are not available separately this setting has no effect.

**Table 7. Available functions for the GPIO signals.**

Function Name	Description
No Function	The GPIOx has no function. The pin is at high impedance state.
Data Interface	The GPIOx signal is used as digital I/O from the communication interface. Refer to the document 5136 “ <a href="#">TEC Controller Communication Protocol</a> ” for more information. Not available individually for both channels.
TEC OK	The GPIOx signal is logic 1 if the TEC Controller is in the “Ready” or “Run” status. Not available individually for both channels.
Stable	The GPIOx signal is logic 1 if the temperature of the corresponding channel is stable.
HW Enable	The GPIOx signal is used as input to enable the output of the channel. In the tab “Operation” select “HW Enable” as “Output Enable” option. If the signal is logic 1, the TEC Controller is enabled.
Fan PWM	The GPIOx signal is used as PWM output for the Fan Control feature. Only selectable for GPIO3 and GPIO4. (See 6.1.3 Fan for Heatsink Cooling) For this function, the “Hardware Configuration” is usually set to “Out PushPull” to properly drive the PWM input of the fan.
Fan Tacho	The GPIOx signal is used as frequency input for the fan control feature. (See 6.1.3 Fan for Heatsink Cooling) For this function, the “Hardware Configuration” is usually set to “IN Weak Up”, because the fans tacho output has usually an open collector output.
Rmp/Stable	The GPIOx signal is logic 1 if the temperature of the corresponding channel is stable. The GPIOx signal toggles between 1 and 0 at 1 Hz, when the corresponding channel is ramping to the target temperature.
TEC Run	The GPIOx signal is logic 1 if the TEC Controller is in the “Run” status Not available individually for both channels.
TempUp TempDown	The GPIOx signal is used as input signal. At every positive edge (transition from logic 0 to logic 1) the target temperature is increased or decreased by the chosen step size. If the signal is logic 1 for longer than 1 s, the target temperature is changed with increasing speed in the chosen direction. (See 6.1.1 for more information). Pressing both buttons simultaneously for 6 seconds locks or unlocks the buttons.
Pump	The GPIOx signal is set to logic 1 to enable a pump. Use the “CHx Pump Control” settings to configure the behavior.
Lookup Start	The GPIOx signal is used as input signal. A positive edge starts and a negative edge stops lookup table execution. By default, the table ID 0 is executed. The ID to be executed is a volatile setting; it is possible to change it over the communication interface.

Function Name	Description															
Dev Adr +1 Dev Adr +2 Dev Adr +4	The GPIOx signal is used as input signal. For each pin which is logic 1 and with this function enabled, 1, 2 or 4 is added to the device address. This is only done once at startup.															
Fan Stop	The GPIOx signal is used as input signal. If this function is enabled and the corresponding pin is 1, the fan is disabled. If the pin is 0 the fan runs normally.															
Alt Target Tx	The GPIOx signal is used as input signal. This function allows to select up to 4 different target temperatures, by changing the signal level of the pins.															
	<table border="1"> <thead> <tr> <th>Chx Alt Target T2</th> <th>Chx Alt Target T1</th> <th>Selected Target Temp.</th> </tr> </thead> <tbody> <tr> <td>1</td> <td>1</td> <td>Value defined in "Temperature Control" tab</td> </tr> <tr> <td>1</td> <td>0</td> <td>"Temperature 1" from "GPIO Detail" tab</td> </tr> <tr> <td>0</td> <td>1</td> <td>"Temperature 2" from "GPIO Detail" tab</td> </tr> <tr> <td>0</td> <td>0</td> <td>"Temperature 3" from "GPIO Detail" tab</td> </tr> </tbody> </table>	Chx Alt Target T2	Chx Alt Target T1	Selected Target Temp.	1	1	Value defined in "Temperature Control" tab	1	0	"Temperature 1" from "GPIO Detail" tab	0	1	"Temperature 2" from "GPIO Detail" tab	0	0	"Temperature 3" from "GPIO Detail" tab
	Chx Alt Target T2	Chx Alt Target T1	Selected Target Temp.													
	1	1	Value defined in "Temperature Control" tab													
	1	0	"Temperature 1" from "GPIO Detail" tab													
0	1	"Temperature 2" from "GPIO Detail" tab														
0	0	"Temperature 3" from "GPIO Detail" tab														
PowerSt 0A	The GPIOx signal is used as input signal. If the signal is 1, the output current for the corresponding channel is set to 0 A, without disabling or re-initializing the temperature controller. This can be useful for critical measurement cycles.															
Encoder A Encoder B	The GPIOx signal is used as input signal. A Rotary Encoder is to be connected to the Encoder A and Encoder B inputs. It can then be used to change the target temperature.															

The Logic Level of each pin can be assigned under "Level Assignment" in the "GPIO General" Tab. For inputs, Logic Level Positive means that a high voltage is read in as logic 1 while a low voltage (Pin connected to GND) is logic 0. This can be inverted by setting the parameter to "Negative". For outputs, the logic level inverts the Signal when set to "Negative". This means that for example the "TEC OK" signal outputs 0V when the TEC is in "Ready" or "Run" status and the Level Assignment is set to "Negative"

The Pins can be individually configured under "Hardware Configuration" in the "Advanced" → "GPIO General" tab. When a signal is used as an input the hardware configuration must be made accordingly or the function will not be operational. The Hardware configuration is described in Table 8.

**Table 8. GPIO Pins Hardware Configuration**

Function Name	Description
In WeakNo	The GPIO Pin is configured as Input. No PullUp or PullDown Resistor is activated.
In WeakUp	The GPIO Pin is configured as Input. A weak PullUp Resistor to 3.3V of approximately 50kΩ is activated.
In WeakDown	The GPIO Pin is configured as Input. A weak PullDown Resistor of approximately 50kΩ is activated.
OUT PushPull	The GPIO Pin is configured as Push Pull Output. No PullUp or PullDown Resistor is activated.
OUT OD NoPull	The GPIO Pin is configured as an Open Drain Output. No PullUp or PullDown Resistor is activated.
OUT OD WeakUp	The GPIO Pin is configured as an Open Drain Output. A weak PullUp Resistor to 3.3V of approximately 50kΩ is activated.

For input signals like buttons, it is usually easier to set the pin to “Negative” logic and “In Weak Up”. This way the switch can be connected between the GPIO pin and GND.

### 6.1.1 Buttons

The target temperature can be changed through two buttons connected to the GPIO connector.

- It’s recommended to connect the buttons between the GND pin and another GPIOx pin and set the Hardware Configuration to “In WeakUp” and use negative logic.
- Pressing both buttons simultaneously for 6 seconds locks or unlocks the buttons.

The Buttons can be configured in the “Advanced” → “GPIO Detail” tab. See Table 9 for a description of the settings.

**Table 9. CHx change target temperature buttons configuration.**

Parameter Name	Options and Description
Upper Temperature Limit	Specifies the maximum Target Temperature which can be set by using the up button.
Lower Temperature Limit	Specifies the minimum Target Temperature which can be set by using the down button.
Step Size	Specifies the single step size, applied on every edge.

### 6.1.2 Rotary Encoders

The target temperatures can be changed by connecting a rotary encoder for each channel to the GPIOs.

- It is recommended to connect the rotary encoder common connection to GND and the outputs to the GPIOx pins.
- With continuous rotation the step size is automatically increased to facilitate large changes in the target temperature.
- The direction of rotation in which the target temperature is increased or decreased can be changed by swapping output A with output B and vice versa.

The Step Size and Temperature Limit settings from “CHx Change Temperature Buttons” are used for the Rotary Encoders.

#### 6.1.2.1 Encoder Recommendations

Meerstetter Engineering has tested the following encoders which fulfill the above-mentioned requirements.

Manufacturer P/N	Digi Key P/N	Resolution
TT BI EN11-HSM1AF15	987-1188-ND	20 Pulses per Revolution
Bourns PEC11R-4215F-N0024	PEC11R-4215F-N0024-ND	24 Pulses per Revolution
Panasonic EVE-WRHJR012B	P15917-ND	12 Pulses per Revolution

### 6.1.3 Fan for Heatsink Cooling

Up to two fans can be connected and controlled by the TEC Controller. The “Fan Control Feature” is intended to keep the heatsink temperature below a specified temperature, by using the

slowest fan speed possible. Please refer to chapter 6.1 on how to configure the fan control signals.

### 6.1.3.1 Fan Requirements

The “Fan Control Feature” is only compatible to fans with the following features:

- PWM control signal input to control the fan speed. The TEC Controller generates a 25 kHz or 1 kHz PWM signal from 0 to 100%. 3.3 V voltage level.
- Optional, but recommended: Frequency generator signal output which represents the rotation speed. The output should be an open collector output signal.

For the logic level voltage definitions of the TEC Controllers, please refer to the datasheets.

### 6.1.3.2 Fan Recommendations

To obviate the need for a separate power supply, it is recommended to use a fan with the same supply voltage as the TEC Controller needs.

We have tested the following fans, which fulfill the above-mentioned requirements. All fans stop (0 rpm) at 0% PWM signal.

**Table 10. Recommended fans.**

Fan	Manufacturer P/N	DigiKey P/N	Voltage [V]	Power [W]	Dimensions [mm]		
					L	H	W
1	FFB0424VHN-TZT4	603-1818-ND	24	2.40	40	40	28
2	AFB0624EH-SP50	603-1803-ND	24	5.76	60	60	25
3	PFB0824DHE-YDG	603-2028-ND	24	32.40	80	80	38
4	AFB1224EHE-EP	603-1735-ND	24	20.40	120	120	38
5	FFB0412VHN-TP03	603-1206-ND	12	1.92	40	40	28
6	AFB0612DH-TP11	603-1211-ND	12	10.08	60	60	25
7	EFC0812DB-F00	603-1159-ND	12	3.96	80	80	15
8	FFC1212D-F00	603-1789-ND	12	17.40	120	120	25
9	PF40281BX-000U-S99	259-1666-ND	12	10.80	40	40	28

### 6.1.3.3 Optimized Settings

The following values are optimal settings for the CHx Fan Speed Controller parameters of the TEC Controller in combination with the corresponding fan. The bypass option (“Bypassing Speed Controller”) is used for fans with integrated speed controller, to disable the TEC Controller’s speed controller.

Fan	0% Speed [rpm]	100% Speed [rpm]	Kp [%/rpm]	Ti [s]	Td [s]	Bypass
1	-	-	-	-	-	Yes
2	-	-	-	-	-	Yes
3	-	-	-	-	-	Yes
4	-	-	-	-	-	Yes
5	0	10000	0.005	0.5	0	No
6	0	10000	0.005	0.5	0	No
7	0	4200	0.005	0.5	0	No
8	0	4400	0.005	0.5	0	No
9	0	22500	-	-	-	Yes

#### 6.1.3.4 Connecting the Fan to the TEC Controller

- If the fan supports the same supply voltage as the TEC Controller, it is recommended to connect the fan's GND and VCC to the TEC Controller's GND and VIN, respectively.
- If a separate power supply is used for the fan, make sure that the two GND terminals of the power supplies are connected. Never leave the fan's GND unconnected, when the fan is powered. Otherwise, the GPIOx pins may be destroyed.
- Assign the correct function to the GPIO signals (See [6.1 GPIO1 – GPIO8 Control Signals](#))
- The fan's PWM input must be connected to GPIO3 or GPIO4, since only these outputs generate a PWM signal.
- The fan's frequency output signal can be connected to any of the GPIO signals.

#### 6.1.3.5 Control Function

The Fan Control feature uses two PID controllers.

The first PID controller sets the required cooling power depending on the temperature of the heatsink. In most cases only P control is used. We recommend a value of 30 %/°C for Kp. Thus, for a target temperature of 40 °C the fan will rotate with 0% speed at 40 °C and 90% speed at 43 °C.

This required cooling power is then converted into a nominal fan speed. For example, if the minimum and maximum fan speeds are set to 1000 rpm and 11000 rpm, respectively, the required cooling power of 50% is converted into a nominal fan speed of 6000 rpm.

The second PID controller sets the fan speed by varying the PWM output signal until the nominal fan speed is reached.

The "Fan Speed Controller" should be set up before without temperature regulation of the heatsink. This can be done by setting both the "Target Temperature" and the "100% Speed" to a high value. This allows to use the "0% Speed" as a fixed rotation speed. The fan should reach the nominal speed as fast as possible.

It is possible to stop the fan by an external GPIOx signal. This is useful, e.g., if a door of a compartment is opened (See 6.1)

If a hysteresis is needed the parameters "Min Speed Start" and "Min Speed Stop" can be used. If those values are set to zero they will be ignored.

### 6.1.3.6 Fan Parameter Description

Table 11. CHx Fan Control Enable

Parameter Name	Options and Description
Fan Control Enable	<ul style="list-style-type: none"> <li>• Disabled</li> <li>• Enabled: Enables the fan controller</li> </ul>

Table 12. CHx Fan Temperature Controller

Parameter Name	Options and Description
Actual Temperature Source	<ul style="list-style-type: none"> <li>• CHx Sink: The Actual Temperature for the temperature controller is taken from the Sink Temperature of channel x</li> <li>• CHx Object: The Actual Temperature for the temperature controller is taken from the Object Temperature of channel x</li> <li>• Device: The Actual Temperature for the temperature controller is taken from the temperature of the TEC Controller</li> </ul>
Target Temperature	Target temperature (set point) for the temperature controller
Kp, Ti, Td	PID controller parameters for the temperature controller

Table 13. CHx Fan Temperature Controller

Parameter Name	Options and Description
0% Speed	Minimum rotation speed
100% Speed	Maximum rotation speed
Min Speed Start	Minimal speed above which the fan is started
Min Speed Stop	Minimal speed below which the fan is stopped
Kp, Ti, Td	PID controller parameters for the Fan Speed Controller
Bypassing Speed Controller	<ul style="list-style-type: none"> <li>• Yes: Disables the Fan Speed Controller. "Relative Cooling Power" is written directly to the PWM output</li> <li>• No: The built-in speed controller is used</li> </ul>
Fan Surveillance	Disables Error 175 (ERROR_FAN_CONTROL_LIMIT) and Error 176 (ERROR_FAN_BLOCKED) This can be used when no tachometer signal is available.

## 6.2 Display Kit (DPY-1113) and others

The additional OLED display kit DPY-1113, which features two lines with 16 chars, can be attached to the TEC Controllers. In case of the TEC-1092, the DPY-1113 can only be used in combination with the evaluation board EVL-1093.

Please ask the sales team for bigger displays up to 4x20 chars

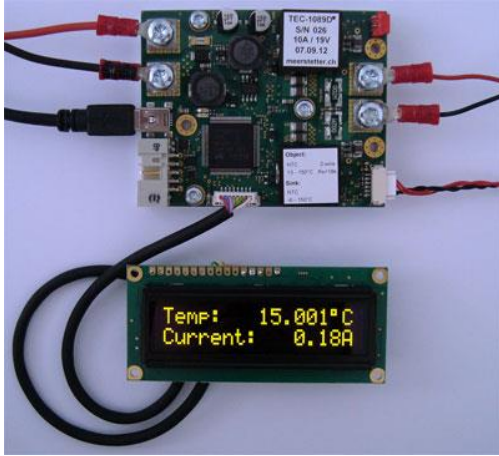

Figure 9. The DPY-1113 connected to a TEC-1089 TEC Controller, displaying the object temperature and the output current.

You must enable the DPY-1113 and select the information to be displayed in the tab “Advanced”

The TEC Controller has to be reset before the Display becomes active.

**Table 14. General display settings.**

Setting	Options	Description
Display Type	OFF	Disables the display feature
	OLED 2x16	For display: NHD-0216KZW-AY5
	OLED 4x20	For display: NHD-0420DZW-AB5
	Small OLED 2x16	For display: NHD-0216AW-SB3
Line 1 - 4 Default Text	Various (see description below)	Defines the text to be displayed on the corresponding line
Line 1 – 4 Alternative Text	Various (see description below)	Defines the text to be displayed for the alternative mode
Line 1 – 4 Startup Text	Various (see description below)	Defines the text to be displayed at the startup of the controller
Line 1 – 4 Alternative Mode	None	No alternative information is displayed
	On Error	If the TEC Controller is in Error state, the alternative information is being displayed
	Toggle on Error	If the TEC Controller is in Error state, the alternative information is being toggled with the default information.
	Toggle	The default information is toggled with the alternative information.

### 6.2.1.1 Display Text

The Display can be used to show fully user-configurable text including all accessible parameters.

Text consisting of standard characters will just be shown as is on the display. To incorporate parameters please follow the syntax described below. Multiple parameters can be displayed on a single line, the only limit is the numbers of characters of the display.

### 6.2.1.2 Displaying System Parameters

The syntax for the “Display Format Argument String” is as follows:

User Text: {Parameter Syntax} Other User Text

- User Text: Text defined by the user. Will be displayed as is.
- {Parameter Syntax} System Parameter according to the syntax description below.
- Other User Text: Text defined by the user. Will be displayed as is.

Text and System Parameters can be displayed in any order and in any number, which enables the displaying of a vast variety of information.

User Text 1{Parameter Syntax}User Text 2{Parameter Syntax}{Parameter Syntax}User Text 3

#### 6.2.1.2.1 Parameter Syntax

{Parameter ID;Parameter Instance;Fractional Points;Number of Digits;Argument Type;Argument ID}

Field	Value Range	Description
Parameter ID	0 – 65535	Parameter ID as described in the “TEC Controller Communication Protocol 5136” document
Parameter Instance	1 – 255	Parameter Instance as described in the “TEC Controller Communication Protocol 5136” document. Usually Instance 1 is TEC CH1 and Instance 2 is TEC CH2.
Fractional Points	0 – 6	Number of digits shown after the decimal point
Number of Digits	0 – 13	Number of total digits shown
Argument Type	0 – 1	Optional argument type 1 = Temp Format
Argument ID	Char	Optional argument ID Temp Format (1) : C = Celsius (Default) F = Fahrenheit K = Kelvin

### 6.2.1.3 Examples

To further clarify let's take apart an example display text:

**Object:**{1000;1;2;5}°C

**Object:** Text defined by user. Display will show "Object"

**{1000;1;2;5}** TEC Controller Parameter ID. Refer to section "Parameter Syntax". Display will show "23.12" (23.12°C is the Object Temperature measured by the controller).

**°C** Text defined by user. Display will show "°C"

To get a better understanding of how to set display text here are some examples:

Text	Text Shown on Display	Description
Object: {1000;1;2;5}°C	Object: 23.12°C	Channel 1 Object Temperature
Sink: {1001;1;1;4}°C	Sink: 25.1°C	Channel 1 Sink Temperature
Current: {1020;1;2;4}A	Current: 1.22A	Channel 1 Actual Output Current
Voltage: {1021;2;2;5}A	Voltage: 4.23V	Channel 2 Actual Output Voltage
Target: {1010;1;2;5}°C	Target: 15.00°C	Channel 1 Target Temperature
Target: {1010;2;1;4}°C	Target: 20.0°C	Channel 2 Target Temperature
Status: {104;1;0;2}	Status: 2	TEC Controller Status
Stat: {104;1;0;2} Err: {105;1;0;2}	Stat: 1 Err: 0	TEC Controller Status and Error Number

The following configuration will show the object temperature of both channels and the output current and output voltage of both channels:

Default Text 1 :	CH1 Temp: {1000;1;3;8}°C
Default Text 2 :	CH2 Temp: {1000;2;3;8}°C
Default Text 3 :	CH1: {1020;1;1;6}A {1021;1;1;6}V
Default Text 4 :	CH1: {1020;2;1;6}A {1021;2;1;6}V

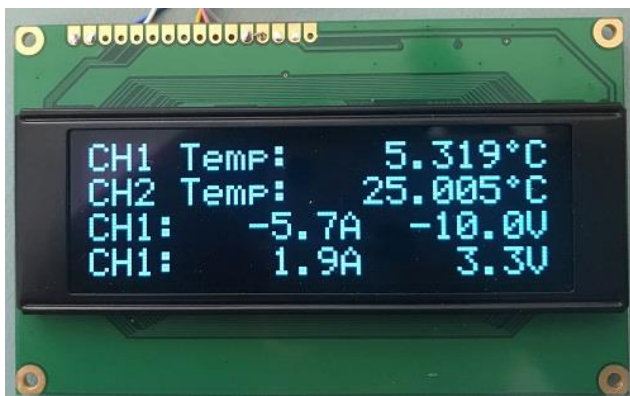

Figure 10: Display 4x20 Character example

#### 6.2.1.4 Displaying Error Messages and Information

The TEC Controller can display an error description if needed. To do this, use the Syntax described below:

{ERRMSG} A short Error message is displayed. If there is no error, the TEC-Controller status is shown.

{ERRINF} Error Information is Displayed in the following way: "Err: Error Number.Error Instance.Error Parameter".

If no Error is currently present 0 is being displayed as Error Information.

## 7 Special Functions

### 7.1 Lookup Table Processing & Scripting

TEC Controllers are capable of storing and executing temperature profiles with predefined curves, ramps, slopes and hold times. These temperature profiles are defined with a script language.

Processing of lookup tables (LUT) is controllable over remote control. The MeCom communication protocol allows sub-table selection, choosing the number of repetitions, starting and stopping the processing and reading status information. LUT processing can be started over hardware GPIOx signals.

#### 7.1.1 Lookup Table Control from Within the Service Software

LUT processing is accessible in the Service Software in the tab “Advanced” → “Lookup Table”. Make sure that prior to using the lookup table processing, the TEC Controller is well tuned.

- Lookup table processing is not only available if the TEC Controller is operating in the “Temperature Controller” mode (see tab “Operation”) and the “CH1 Output Stage Enable” must not be set to “Live OFF/ON”, but this is the normal case. In case you want to drive a current/voltage profile, then you can set it to Live Current/Voltage and write to the corresponding parameters.
- Click “Load CSV File” to choose a LUT and save it to the controller’s memory by clicking on “Download”.
- For each TEC Controller channel, select the table ID and the number of executions.
- Click “Start” to enable processing of the table.
- While processing LUTs, the TEC Controller will ignore any other temperature settings, i.e., in the tab “Temperature Control”.
- Once all instructions of the LUT have been executed or when LUT control is cancelled, the TEC Controller’s channel returns to its previous state.

#### 7.1.2 Instruction Set and Available Options

One single LUT instruction is defined as line with three elements, separated by semicolons: Instruction; Field1; Field2

The third element, Field2, is not always used.

The definition of the instruction set and an example LUT are included in the [“TEC-Family TEC Controllers Software Package”](#).

## 7.2 Parameter handling

### 7.2.1 Settings Dump (.mepar File) with TEC Service Software

In cases where many or all settings of a TEC Controller are to be changed from a host software or a host microcontroller, a settings dump function is available. This generates a file which can be dumped to a TEC Controller using third party host systems.

- Every parameter which is labeled with “New”, that contains information will be stored in the .mepar file.
- In the “Maintenance” tab click “Create File” in the box “Create \*.mepar file (for Settings Dump)”.
- For every parameter stored in the .mepar file, a line contains the parameter string that is specific to function, firmware and device type.
- Using the MeCom communication protocol, the .mepar file can be sent line-by-line to one or several devices. These batch configurations will immediately become active.
- It is also possible to download just one single setting (i.e., one line of the .mepar file) directly from the Service Software to a TEC Controller.
- Copy a line from the file and paste it in the field. Click “Send String”.

### 7.2.2 Parameter System Save to Flash Configuration (Save Data to Flash)

Table 15. Settings saving behavior.

Option	Options and Description
Enabled	Default setting. Every time a parameter is changed a 0.5 s delay timer is started. After expiration, all changed data is saved to the non-volatile flash.
Disabled	Saving data to the non-volatile flash is disabled. This is useful when the TEC Controller is connected in a bus system, where parameters are changed regularly. This prevents the flash from early failure.

## 7.3 Special Settings

### 7.3.1 Power Stage overtemperature behavior

The behavior of the firmware depends on the device temperature of the TEC Controller, which is regularly measured. Refer to the datasheet of the corresponding TEC Controller for more information about the current to temperature relationship.

The temperature depending behavior can be changed in the tab “Advanced” → “Misc”.

**Table 16. Device Temperature Mode (Output Stage)**

Option	Options and Description
Standard	Fixed error temperature limits are applied. If the device temperature reaches the limit, the <code>OVERTEMPERATURE</code> error is thrown.
Extended	The extended temperature range is enabled. Depending on the device temperature the current is being limited. You can find the corresponding limit curves in our TEC Controller Datasheets.

### 7.3.2 Error State Auto Reset Delay

If the system is in the error state, it restarts after a specified time. This feature is disabled if a time of 0 s is specified. The auto reset is delayed for a fixed time of 20 s after starting up.

## 8 Appendix

### 8.1 Troubleshooting

Table 17. Typical Problems

Problems	Possible Reason	Possible Solution
The Service Software is not starting	The Service Software does not work with 64 bit versions of Microsoft Visual C++ 2015 Redistributable Package	Make sure that the correct version (32 bit) of Microsoft Visual C++ 2015 Redistributable Package is installed.
I want to use a NTC10K sensor. Is it compatible with a NTC18K (or NTC39K, NTC56K, NTC1M) configuration?		Yes. See <a href="#">3.1.1.1 Example NTC Configuration</a> for a detailed description.
The output is suddenly switched off	The “Upper and Lower Error Threshold” aren’t set correctly	Check the error message in the “Monitor” tab. Make sure that the “Upper and Lower Error Threshold” are set correctly in the “Object Temperature” tab.
The Peltier element is heating instead of cooling	The Peltier element is connected the wrong way.	Switch the wires of the Peltier element at the connector of the TEC Controller. Or switch “Positive current is” from heating to cooling in Tab “Temperature Control”
	The parasitic heat generated in the Peltier module can no longer be dissipated.	Reduce the current and/or improve the cooling of the heatsink.
The firmware is too old	The firmware of the TEC Controller is too old to connect to the Service Software.	Please update the firmware as described in <a href="#">2.4 Firmware Updates</a> .
The temperature stability is worse than expected	There are several reasons, here are the most important ones: interference (temperature, electrical) temperature sensors are placed wrong.	To achieve a stable object temperature, the cold side and the object must be insulated from the environment. Check position and behavior of the temperature sensors
CHx Output Stage Controller Limit (Error 108)	This usually happens if the TEC Controller’s input voltage is too low for the desired output voltage.	Use power supply with sufficient output current and voltage.
		As a first measure, you may reduce the “Current Limitation” value in the “Operation” tab.

## 8.2 Error Numbers, Instances and Parameters

- Error Numbers from 1 through 99 designate error conditions that are universal across the whole range of Meerstetter advanced TEC Controllers and laser diode drivers. Error numbers starting from 100 designate conditions that are specific to TEC-Family devices (see tables below).
- Error Instance typically designates the channel involved. For TEC-1092-based, TEC-1091-based and TEC-1089-based devices it is 1. For TEC-1122-based devices, it can be 1 or 2.
- Error Parameters are additional information helping the software engineers at Meerstetter Engineering in the processes of error diagnosis or remote debugging.

### 8.2.1 Error Numbers 1 - 99 (Universal, for TEC-Family and LDD-Family devices)

Table 18. Processor Errors

#	Description	Error Condition
1 - 10	MCU system malfunction	-

Table 19. HMI Errors

#	Description	Error Condition
11	Emergency stop was triggered by LTR-1200	-
12	LTR-1200 HMI regularly sends 'free' signals to all rack-internal devices such that they are allowed to activate their output stages (if enabled)	No signal received for more than one second

Table 20. Parameter System Errors

#	Description	Error Condition
20-21	Internal parameter system malfunction	-
22	Parameter set corrupt	Configuration flash empty or defect (Remedy cf. error #23)
23	Parameter set incompatible with current firmware version	Load .ini file saved prior to FW update, or Default.ini
24	Firmware does not recognize valid device	-
25	Internal parameter system malfunction	Access to a non-existing instance
26	Internal limit system malfunction	-
27	Parameter write or read wrong datatype function used	-
28	Parameter write value out of range	-
29	Parameter save to flash called from interrupt	-

**Table 21. Power Supply Errors**

#	Description	Error Condition
30	Input voltage net too low	< 10.5V < 4.8V for TEC-1092/1091/1161
31	Input voltage net too high	> 27.0V for -SV > 38.0V for -HV > 14.0V for TEC-1092 > 25.5V for TEC-1091/1161
32	Internal Medium Voltage power net too low	< 8.0V (HW Version Depending) < 4.7V for TEC-1092/1091/1161
33	Internal Medium Voltage power net to high	> 9V (HW Version Depending) > 5.25V for TEC-1092/1091/1161
36	Internal 3.3V power net too low	< 3.1V
37	Internal 3.3V power net too high	> 3.5V

**Table 22. Flash Memory Errors**

#	Description	Error Condition
50	On-board flash failure	Write Timeout
51	On-board flash failure	Erase Timeout
52	On-board flash failure	Invalid Address

**Table 23. Communication (UART) Error**

#	Description	Error Condition
53	Send buffer overflow error	-

**Table 24. Device Temperature and Hardware Errors**

#	Description	Error Condition
60	Device running too hot	See datasheet.
61	Communication error with I/O hardware during factory test	-

## 8.2.2 Error Numbers 100 - ... (Specific for TEC-Family devices)

Table 25. Power Output Errors

#	Description	Error Condition
100	Overcurrent, Driver CHx OUT+	> 'Current Error Threshold'
101	Overcurrent, Driver CHx OUT+	> 'Current Error Threshold'
102	Overcurrent, Driver CHx OUT-	> 'Current Error Threshold'
103	Overcurrent, Driver CHx OUT-	> 'Current Error Threshold'
104	Overvoltage, Driver CHx OUT+	> 'Voltage Error Threshold'
105	Overvoltage, Driver CHx OUT+	> 'Voltage Error Threshold'
106	Residual current too high. The Current difference between OUT+ and OUT- is too big.	$Abs(OUT+ - OUT-) > I_{max} * 0.1$
107	Overall current monitoring, triggers fast switch off (within 10 $\mu$ s)	Approximately 150% of the nominal maximal output current.
108	Output Stage saturation error. Check input current is sufficient and $V_{out}$ not set too close to $V_{in}$ . Try to reduce the "Current Limitation" in the Operation tab.	Output Stage is in saturation for more than 1ms. This time can be changed by a user setting.
109	Currents through OUT+ and OUT- too unequal	Leak current at output, faulty current detection
110	TEC Power Output Error: Allowed total output power reached	-
111	The connected load has a too low resistance in comparison to the input voltage	-

Table 26. Current Measurement Errors

#	Description	Error Condition
120	Offset during initialization of current monitor too high, Driver CHx OUT+	-
121	Offset during initialization of current monitor too low, Driver CHx OUT+	-
122	Offset during initialization of current monitor too high, Driver CHx OUT+	-
123	Offset during initialization of current monitor too low, Driver CHx OUT+	-

**Table 27. Object Temperature Measurement Errors**

#	Description	Error Condition
130	Object Temperature Measurement Circuit Initialization failure.	Wrong detected ready signal.
131	Object Temperature Measurement Circuit failure.	Configuration read back failed.
132	External ADC supply voltage out of range	-5% < AVDD < +5%
133	23bit ADC raw value below safety margin	< 500000 (6%)
134	23bit ADC raw value above safety margin or the measured resistance is too high.	ADC > 8350000 (99.5%) R > 1MΩ
137	Measured object temperature out of permitted range	< 'Lower Error Threshold'
138	Measured object temperature out of permitted range	> 'Upper Error Threshold'
139	Change in measured object temperature too fast (outpacing thermal inertia)	> 'Max Temp Change' while 20 succeeding cycles in to the same direction.
150	Object Temperature Measurement Circuit failure.	Several times the same ADC value read.
151	Object Temperature Measurement Circuit failure.	Several times the same ADC value read.
152	Object Temperature Measurement Circuit failure.	ADS Self Check failed. IRs out of range
153	Object Temperature Measurement Circuit failure.	ADS Self Check failed. VRef out of range

**Table 28. Sink Temperature Measurement Errors**

#	Description	Error Condition
140	12bit ADC raw value below safety margin	< 40 (1%)
141	12bit ADC raw value above safety margin	> 4050 (99%)
142	Measured sink temperature too low	< 'Lower Error Threshold'
143	Measured sink temperature too high	> 'Upper Error Threshold'
144	Change in measured sink temperature too fast (outpacing thermal inertia)	> 'Max Temp Change' while 20 succeeding cycles in to the same direction.

**Table 29. Autotune Errors**

#	Description	Error Condition
170	Progress Error	
171	Auto tuning failures at three consecutive attempts	More than 40% discrepancy in temperature
172	Auto tuning failures at three consecutive attempts	More than 40% discrepancy in waveform period
173	The Temperature Controller is in its limitation or is not running.	

**Table 30. Fan Control Errors**

#	Description	Error Condition
175	The Fan does not reach the desired rotation speed.	Fan PWM Signal is 100% and the reached Speed is < 60% of the nominal speed while 12s
176	The Fan does not rotate	Fan Speed = 0 and PWM Level > 35% while 10s

**Table 31. Lookup Table Errors**

#	Description	Error Condition
180	Unknown Instruction	-
181	Misuse of an Instruction	-

**Table 32. Various Errors**

#	Description	Error Condition
182	Temperature Stability not reached in specified time.	-
183	No package has been received within the specified Watchdog timeout time.	-
184	Syntax Error in Display Format Argument String	-
185	Firmware Update Error	You tried to download a too old firmware version
186	Firmware Update Error	You tried to download a firmware from a different device