



Developed, assembled and tested in Switzerland

# User Manual

## TEC Controller

(Thermoelectric-Cooling/ Peltier Element Controller)

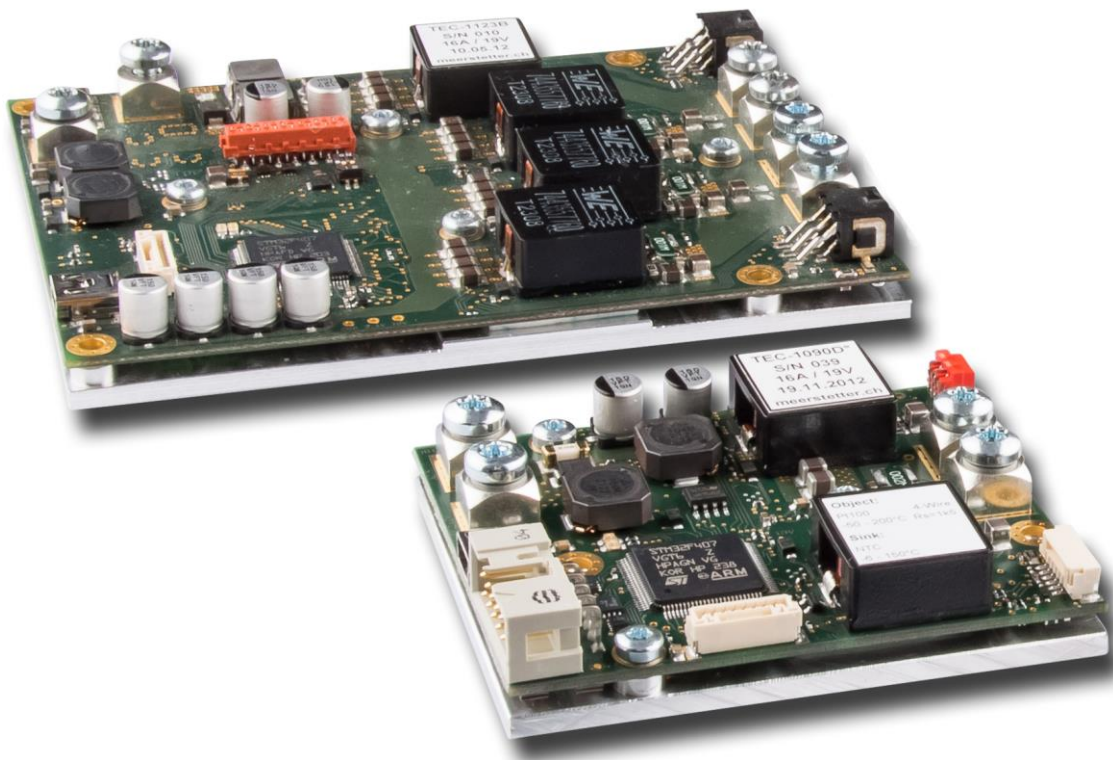

### TEC-Family:

TEC-1089

TEC-1090

TEC-1122

TEC-1123

Meerstetter Engineering GmbH  
Schulhausgasse 12  
3113 Rubigen, Switzerland



Phone: +41 31 712 01 01  
Email: [contact@meerstetter.ch](mailto:contact@meerstetter.ch)  
Website: [www.meerstetter.ch](http://www.meerstetter.ch)

*Meerstetter Engineering GmbH (ME) reserves the right to make changes without further notice to the product described herein. Information furnished by ME is believed to be accurate and reliable. However typical parameters can vary depending on the application and actual performance may vary over time. All operating parameters must be validated by the customer under actual application conditions.*



# Table of Content

<b>1</b>	<b>Overview TEC-1089-based TEC Controllers</b>	<b>5</b>
<b>2</b>	<b>Overview TEC-1122-based TEC Controllers</b>	<b>6</b>
<b>3</b>	<b>Introduction to the TEC-Family of Digital Temperature Controllers</b>	<b>7</b>
<b>4</b>	<b>Getting Started, Step-by-Step</b>	<b>7</b>
4.1	Software Installation	7
4.2	Mounting and Powering-Up the Peltier Controller	8
4.3	Hardware and Status Verification	9
4.4	Monitor Tab, Software Ergonomics / Organization	10
4.5	Configuration Tab 'Operation', Transfer of Configuration Parameters	11
4.6	Temperature Measurements Preparation	13
4.7	Object (and Sink) Temperature Acquisition	16
4.8	Connection of a Peltier Element	17
4.9	Temperature Regulation / Digital Temperature Control	19
<b>5</b>	<b>Advanced Operation</b>	<b>21</b>
5.1	Charting and Data Logging	21
5.2	Temperature Stability Indication	22
5.3	Two Channel Operation and Parallel Mode Selection	23
5.4	Auto Tuning / System Optimization	23
5.5	Configurations and Parameter Activation	25
5.6	Device Configurations Handling	26
5.7	Firmware Updates	27
5.8	Remote Control / Bus Control by Communication Protocol 'MeCom'	28
5.9	Remote Control / Service Communication by TEC Service Software	29
<b>6</b>	<b>Scriptable Control by Lookup Table Processing (Expert Operation)</b>	<b>32</b>
6.1	Lookup Table Control from within TEC Service Software	32
6.2	Instruction Set and Available Options	33
6.3	Example Lookup Table Generation/Editing and Export	34
<b>7</b>	<b>Temperature Acquisition Hardware and Configuration (Expert Settings)</b>	<b>35</b>
7.1	Object and Sink Temperature Sensors and Input Configurations	35
7.2	[optional] Use and Configuration of NTC Temperature Probes	36
7.3	Calibration and Hardware Settings (Service Software 'Expert' Tab)	37
7.4	Temperature Probes Assembly	37
7.5	Temperature Acquisition ADC Circuitry Calibration	38
<b>8</b>	<b>Special Functions and Optional Hardware</b>	<b>39</b>
8.1	Optional Display Kit (DPY-1113)	39
8.2	PBC (Platform Bus Connector) RES1 ... RES8 Control Signals	41
8.3	FAN Control Feature	41

8.4 Misc Expert Settings..... 44

**Appendix 1 Peltier Controller Factory Settings ..... 45**

**Appendix 2 TEC Controller Status LEDs and Error Codes ..... 48**

# 1 Overview TEC-1089-based TEC Controllers

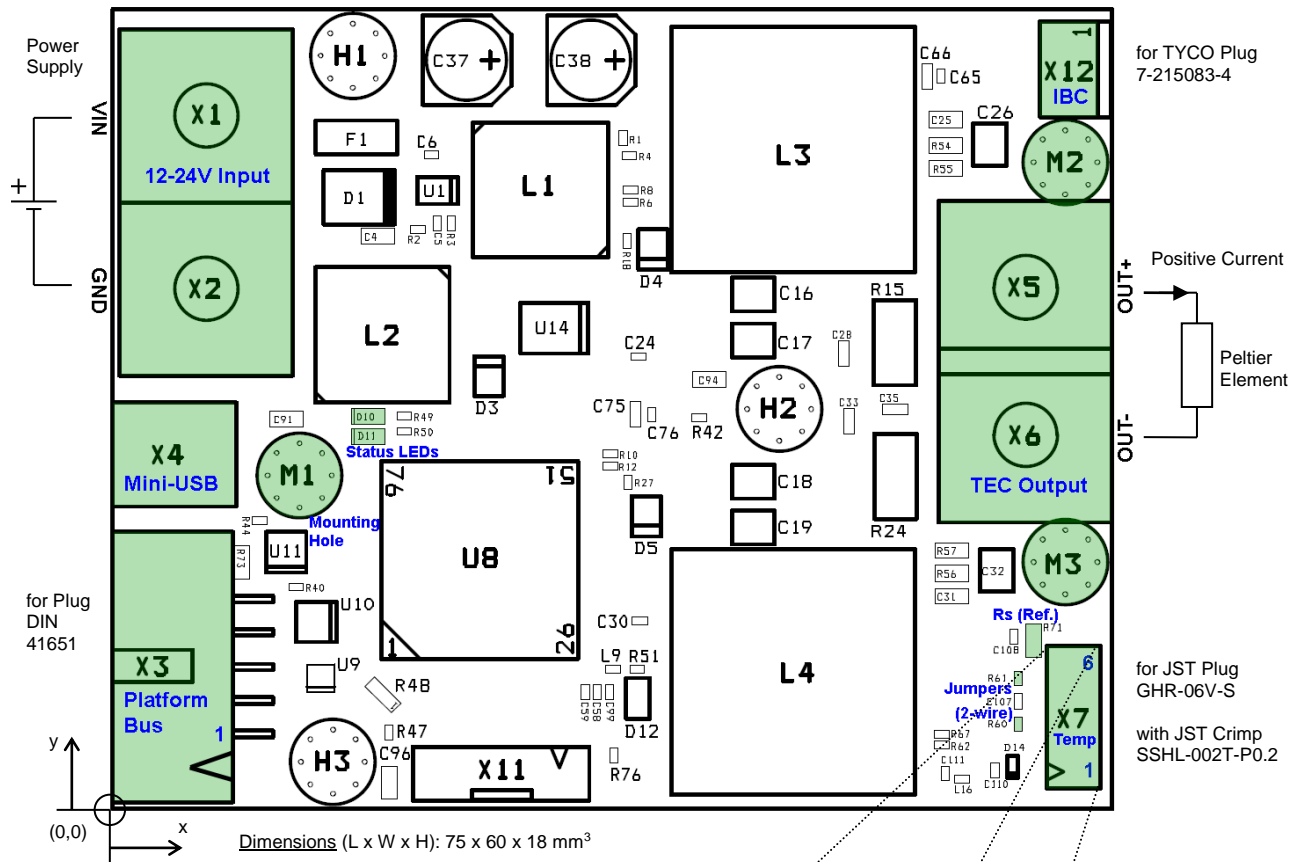

**Mounting** (M3-size Bores, 7.5 mm in Length):

- M1: x = 14.0 mm, y = 25.0 mm
- M2: x = 71.5 mm, y = 48.5 mm
- M3: x = 71.5 mm, y = 18.5 mm

**Power Terminals:** M4-size Screws

**Pin Descriptions** Platform Bus X3:

- 1: 24V (optional)
- 2: GND (fused, PTC)
- 3: RS485\_A1 [\*R72 = Termination (120Ω), N.A.]
- 4: RS485\_B1 [\*R72 not accessible from top]
- 5: RS485\_A2 [R73 = Termination (120Ω), N.A.]
- 6: RS485\_B2
- 7: RES1
- 8: RES2
- 9: RES3
- 10: RES4

TEC Board

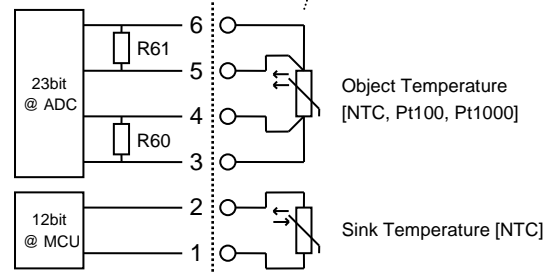

R60, R61 = Jumpers (0Ω)  
R71 = Rs (Shunt / Reference)

Figure 1. Schematic top view of a TEC-1089-based single-channel TEC controller.

Elements relevant to the end-user are highlighted.

The Platform Bus (X3) allows connection to a remote control system (e.g. also controlling a laser diode driver). The inter-board connection (IBC, X12) permits pairing with another TEC-1089-based TEC driver. [This functionality is currently not supported.]

Power supply, temperature sensors and Peltier element not included.

## 2 Overview TEC-1122-based TEC Controllers

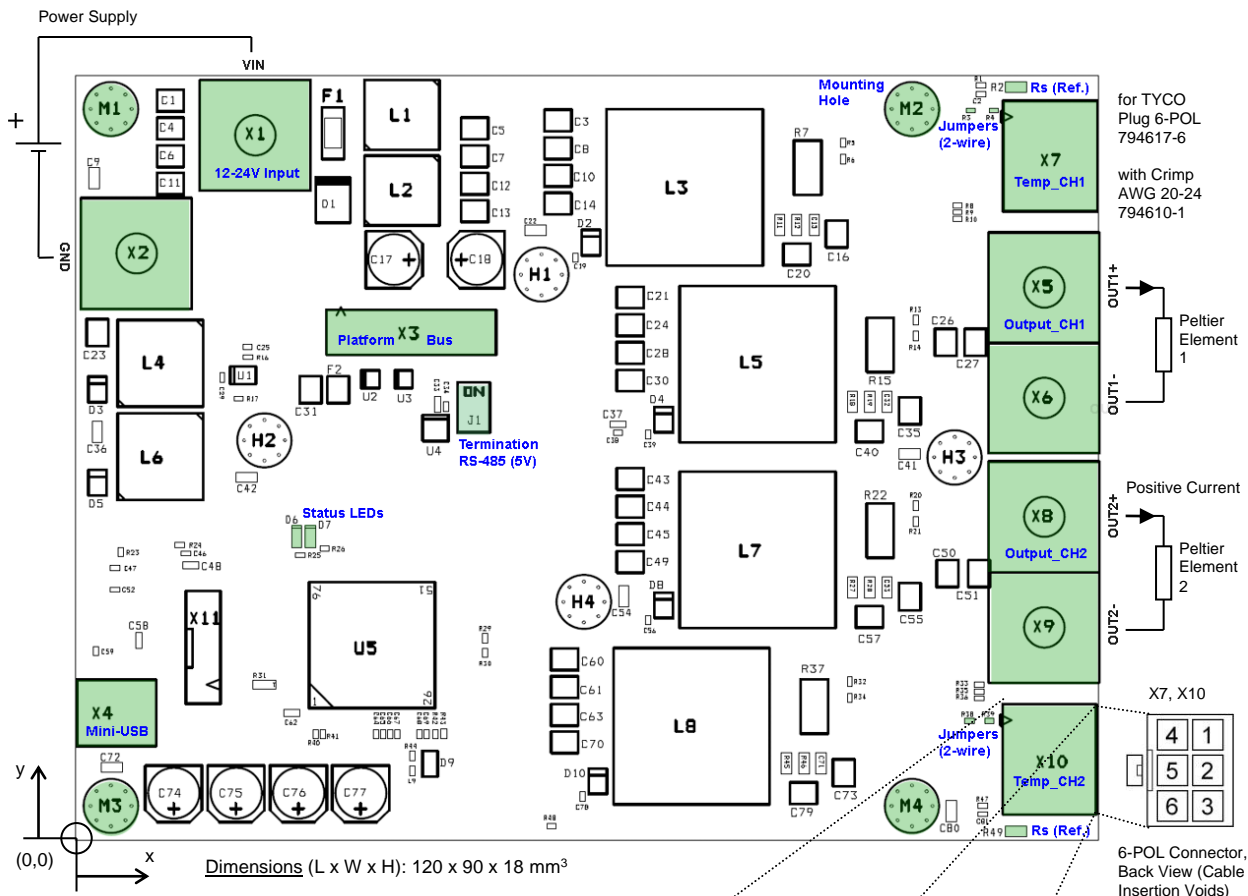

### Mounting (M3-size Bores, 7.5 mm in Length):

- M1: x = 4.0 mm, y = 86.0 mm
- M2: x = 98.0 mm, y = 86.0 mm
- M3: x = 4.0 mm, y = 4.0 mm
- M4: x = 98.0 mm, y = 4.0 mm

### Power Terminals: M4-size Screws

### Pin Descriptions Platform Bus X3:

- 1: GND (fused, PTC) for TYCO Plug 14-POL 8-215083-4
- 2: RES1
- 3: RES2
- 4: RES3
- 5: RES4
- 6: RES5
- 7: RES6
- 8: PULSE [not used]
- 9: ENABLE [not used]
- 10: GND (fused, PTC)
- 11: RS485\_A1 [120Ω Termination, DIP-Switch J1, 1]
- 12: RS485\_B1
- 13: RS485\_A2 [120Ω Termination, DIP-Switch J1, 2]
- 14: RS485\_B2

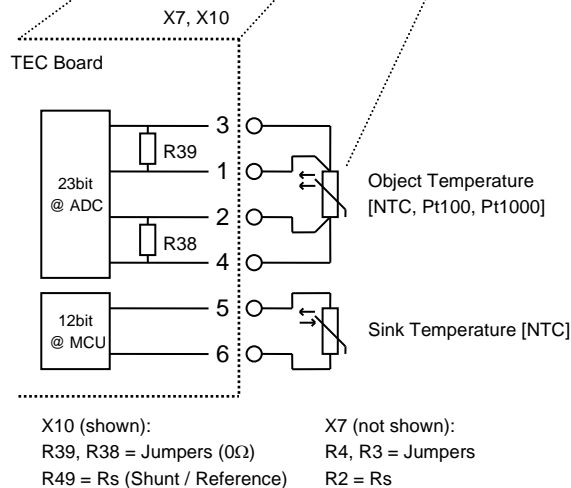

Figure 2. Schematic top view of a TEC-1122-based dual-channel TEC controller.

Elements relevant to the end-user are highlighted.

The Platform Bus (X3) allows connection to an LDD-1121-based laser diode driver.

Power supply, temperature sensors and Peltier elements not included.

### 3 Introduction to the TEC-Family of Digital Temperature Controllers

This manual is written for products belonging to the TEC-Family of advanced thermoelectric cooling drivers / digital temperature controllers. All models are either based on the TEC-1089, which is a compact Peltier controller, or on the TEC-1122, which is a dual channel controller that shares the same architecture and microcontroller platform. To double output current, two channels of TEC-1122-based devices can be operated in parallel mode.

All members of the TEC-Family can be used as temperature regulators (TEC controllers) or as power supplies, both in stand-alone and in remotely-controlled (RS485 / USB) operation. The TEC-1122 has been developed to work along the LDD-1121, an advanced laser diode driver / controller that shares the same communication bus and hardware architecture. Again, there are several LDD-1121-based devices available, forming the LDD-Family of products.

	Model	Description
TEC-Family Peltier Controllers	TEC-1089	$\pm 10$ A / $\pm 19$ V, Compact, Single Channel
	TEC-1090	$\pm 16$ A / $\pm 19$ V, Compact, Single Channel
	TEC-1122	2x ( $\pm 10$ A / $\pm 19$ V), Dual Channel
	TEC-1123	2x ( $\pm 16$ A / $\pm 19$ V), Dual Channel
LDD-Family Laser Diode Drivers	LDD-1121	0-15 A / 0-15 V, Low-Ripple CW and Pulsed-Mode Operation
	LDD-1125	0-30 A / 0-15 V, Low-Ripple CW and Pulsed-Mode Operation

*Table A. Overview over the Meerstetter TEC and LDD Families of advanced controllers. Meerstetter Engineering GmbH is specialized in supporting custom laser solutions.*

TEC-Family devices are designed to work in support of LDD-Family laser diode drivers. Meerstetter Engineering offers turn-key solutions of systems comprising up to four LDD and TEC devices. These solutions are based on the LTR-1200 Rack Enclosure which includes a human-machine interface (HMI) with further advanced communication and local control features as well as modular cooling and power supply options.

*The present manual covers TEC-Family Firmware and Service Software version 1.41.*

### 4 Getting Started, Step-by-Step

In the following steps, setting up a TEC as a stand-alone single-channel temperature controller driving a Peltier element is described. Unless stated otherwise, 'TEC' designates both TEC-1089-based and TEC-1122-based models.

Bullet points (•) designate actions, tick boxes () feedbacks/reactions, and arrows (←) further information.

#### 4.1 Software Installation

Step 1

##### Install USB Driver

- Start up a PC running Windows XP or Windows 7
- Use a Mini-USB cable to connect the TEC board to the Service PC

*Windows recognizes the USB interface and – if necessary - installs a (Serial Interface) driver*

← In case Windows cannot locate the FTDI USB driver by itself, get it from the Meerstetter LDD and TEC products CD or download the executable 2.08.24 (or newer) from: [http://www.ftdichip.com/Drivers/CDM/CDM20824\\_Setup.exe](http://www.ftdichip.com/Drivers/CDM/CDM20824_Setup.exe)

← This installation does not require the TEC to be powered, yet (the isolated USB interface is bus-powered)

## Step 2

### Install Service Software

- Please ensure the Service PC meets the following requirements:
  - .net Framework 4.0 (.net Web Installer\* *dotNetFx40\_Full\_setup.exe* and Windows Update)
  - Microsoft Visual C++ 2010 [SP1 or above] Redistributable Package\*\*
  - Display resolution: 1024x768 or greater
- Copy the latest version of the Service Software executable (e.g. *TEC Service [version].exe*) to the Service PC and launch it

← All required software and drivers are located on the Meerstetter laser diode driver (LDD-Family) and TEC controller (TEC-Family) products and support CD [me5145]

← \*Online/web installer for .net Framework 4.0: <http://www.microsoft.com/download/en/details.aspx?id=17851> followed by patching via [www.windowsupdate.com](http://www.windowsupdate.com) (several files) and restart

← \*\*32bit version *vc\_redist\_x86.exe*: <http://www.microsoft.com/download/en/details.aspx?id=8328>  
On 64bit versions of Windows 7, the additional installation of *vc\_redist\_x64.exe* may be necessary:  
<http://www.microsoft.com/download/en/details.aspx?id=13523>

← The present Service Software is a tool that has been programmed by Meerstetter Engineering for device configuration, monitoring and debugging. It is being made available to customers for OEM device evaluation, commissioning and operation.

□ *The Service Software will display a 'Device connected, establishing communication' message in the bottom left corner and the red indicator will confirm 'Communication error with device' (the TEC is not yet powered)*

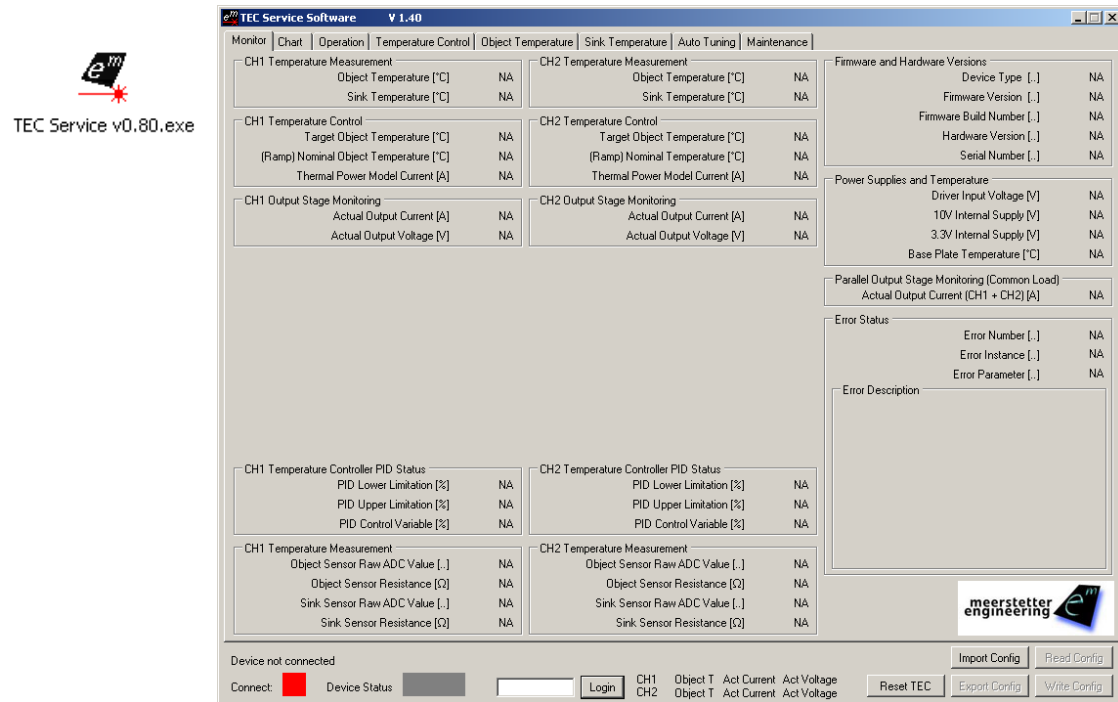

Figure 3. TEC Service Software Icon (Windows XP, Windows 7) and screen at first startup (USB connected, TEC unpowered)

## 4.2 Mounting and Powering-Up the Peltier Controller

### Step 3

#### Mount TEC onto System Carrier Plate

- Locate the four mounting holes M1-M4 (TEC-1089-based: see Figure 1, TEC-1122-based: see Figure 2)
- Use M3 size screws to fasten the TEC controller to the system

← For initial tests / operation at intermittent, low power, it is not necessary to firmly screw the TEC onto a plate. Placing it on a metal plate / heat sink should be sufficient

Step 4 **Connect TEC to Power Supply**

- Connect X1 (VIN) and X2 (GND) to the outputs of the external power supply

← Do not connect the Peltier element, yet

Step 5 **Power up Peltier Controller**

- Enable power supply and check device status

Either the green or the red status LED (see Figure 1 or Figure 2) should be blinking / lit

Step 6 **Successful Connection**

- Check active connection between the TEC controller and its Service Software

The square in the bottom left corner of the Service Software should be green and 'Connected'

The 'Device Status' indicator should be amber and 'Ready'

← A color-coded indicator informs about the current device status, refer to Appendix 2 for more information

### 4.3 Hardware and Status Verification

Step 7 **Identify Firmware and Hardware Versions of your Peltier controller**

- Locate the corresponding group box in the 'Monitor' tab (Tab1)

Take note of the processor and hardware versions

Check the serial number matches the sticker on your TEC

Step 8 **Check 'Power Supplies and Temperature' Status**

- Locate the corresponding group box in Tab1

Check the input voltage matches the one of the external power supply

Check the internal 10V and 3.3V supplies are working at nominal voltage

Check the base plate temperature is reasonable

Step 9 **Check 'Error Status'**

- Locate the corresponding group box in Tab1

Take note of the three error indicators. 0s are shown when no error is present

← Error Number designates the error condition, Error Instance normally indicates the channel concerned. Error Parameter is additional information helping the software engineers with diagnosis and remote debugging. If applicable, a brief Error Description is displayed in the corresponding field. Please consult Appendix 2 for more detail on TEC controller and laser diode driver error codes

## 4.4 Monitor Tab, Software Ergonomics / Organization

Step 10

### Check Channel 1 Status with no Temperature Probes or Peltier Element Connected

- Locate Channel 1 status group boxes in Tab1:
  - 'CH1 Temperature Measurement'
  - 'CH1 Temperature Control'
  - 'CH1 Output Stage Monitoring'
  - 'CH1 Temperature Controller PID Status'
  - 'CH1 Temperature Measurement'

Note that these boxes display status / monitoring information, currently:

- *Object and sink temperatures are static* (no probes connected, sink temperature set to 'fixed')
- *Temperature control parameters are static* (TEC not in controller mode)
- *Actual output current and voltage are zero* (no load connected, output stage disabled)
- *Temperature controller PID values are zero* (TEC not in controller mode)
- *Temperature measurement sensor raw ADC values are at end of range* (no probes connected) *and thus displayed sensor resistances meaningless*

Observe that the arrangement of top three group boxes follows an input-control-output pattern

Note that the bottom two group boxes display more in-depth status of PID control and AD conversion / probes resistance

← Object and sink sensor raw ADC values are converted into object and sink sensor resistances for better readability. These conversions depend on actual hardware configurations (such as reference resistors, probe currents, etc.)

Step 11

### Check Channel 2 Status

- Locate Channel 2 status group boxes in Tab1

Observe that most Service Software tabs are organized in three columns, where the first one is dedicated to CH1 and the second one to CH2 (TEC-1122-based only).

← For reasons of clarity, only CH1 settings are highlighted in this manual. Unless stated otherwise, they are valid for both CH1 and CH2.

## 4.5 Configuration Tab 'Operation', Transfer of Configuration Parameters

### Step 12 Move from the Monitor Tab to a Configuration Tab, Check General Operating Mode

- Switch to Tab3 'Operation'
- Locate the three group boxes to the right

Please check 'General Operating Mode' is set to 'Single (Independent)'

← Refer to chapter 5.3 for detail on general operating modes

[optional] Please check 'RS485 Channel 1 Settings' are compatible with your control system

← Refer to chapter 5.8 for information on RS485 communication

[optional] Attribute a unique 'Device Address' if you are operating multiple TEC controllers or laser diode drivers on the same platform bus, e.g. mounted into an LTR-1200 rack enclosure

The screenshot shows a configuration window with the following sections:

- General Operating Mode\***
  - Actual: Single (Independent)
  - New: [Dropdown menu]
- Device Address**
  - Actual: 2
  - New: [Input field]
- RS485 Channel 1 Settings**
  - Baud Rate\* [.]: 57600
  - Response Delay [us]: 0

← Tab3 is a configuration tab (not a monitoring tab, such as Tab1). In configuration tabs, each parameter displays an actual value next to a blank field for entering a new value

← New values need to be transferred to the device by clicking 'Write Config' in the bottom right corner of the Service Software

← The values transferred to the TEC are considered static. They are saved to non-volatile memory ('Flash') and remain valid upon device reset

← Most operational parameters become active immediately, some hardware configuration parameters require a device Reset to become active. They are designated by a star: \* (see chapter 5.5 and **Fehler! Verweisquelle konnte nicht gefunden werden.**)

**Check Output Stage Control Source, Enable, Current/Voltage and Limits**

- Locate the corresponding group boxes in Tab3

□ Please take the time to check factory settings are set according to the illustration on the right

□ It is important that 'Static Current/Voltage' mode is selected as output stage control input

← There are three sources that can control a channel's output stage:

'Static Current/Voltage' makes the channel behave like a DC power-supply (with set current and voltage, temperature-independent). Values are read from non-volatile memory. If 'Live Current/Voltage' is selected, current and voltage values are taken from the device's volatile memory ('RAM') which can be continuously updated by remote-control.

In the 'Temperature Controller' mode the output current for cooling/heating is calculated by the on-board firmware as a function of temperature and other information

← 'CH1 Output Stage Enable' activates / suppresses channel power output. Static OFF and ON settings are saved to non-volatile memory ('Flash') and remain active upon a device power cycle. 'Live OFF/ON' will read the Enable status from the devices volatile memory ('RAM') and will return to default status OFF upon a device power cycle or reset

← 'CH1 Output Stage Static Current/Voltage Control Values' are read when the TEC controller channel is used as a DC power-supply. The sign of the 'Set Current\*\*' parameter determines polarity of both current and voltage. (The sign of the 'Set Voltage' parameter is ignored.)

← 'CH1 Output Stage Limits' are important safety settings that limit the TEC's output power to protect the connected modules

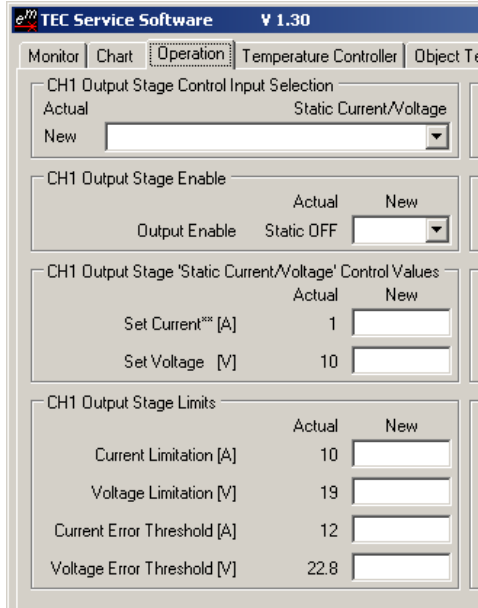

← Both static and live settings can be configured on the fly by bus-control, i.e. by 'MeCom' communication protocol over a serial connection (USB or RS485). The TEC Service Software does not permit to write live/RAM parameters.

← See chapter 5.8 Remote Control / Bus Control by Communication Protocol 'MeCom' for more information on static and live settings.

← Please consult the 'MeCom' communication protocol specification document 5136 for more detail on TEC-Family-specific bus-controlled live/RAM parameters (IDs >50'000).

## 4.6 Temperature Measurements Preparation

### Step 14 Check CH1 Object Temperature Measurement Settings

- Switch to Tab5 'Object Temperature'

□ Please take the time to familiarize with the current temperature measurements settings (see bottom illustration on the right)

← Object temperature measurement uses a dedicated 23bit A/D conversion

← Acquisition circuitry can accommodate three sensor types Pt100, Pt1000, or NTC. The selected type is indicated in the in the group box 'CH1 Object Temperature Measurement Limits' (here: NTC)

← Acquisition hardware settings / calibration data are sensitive to accidental misconfiguration and thus available in a separate, password-protected 'Expert' tab (see chapter 6).

The group box 'CH1 Object Temperature Measurement Limits' indicates the currently readable sensor resistance range (hardware) and the correspondingly calculated temperatures (software)

□ Please note that you can adjust the temperature measurement output to calibrate your sensor [optional]

← Object temperature measurement output is user-modifiable by the 'Temperature Offset' and 'Temperature Gain' parameters. This provides a mean for sensor response adjustment, if required

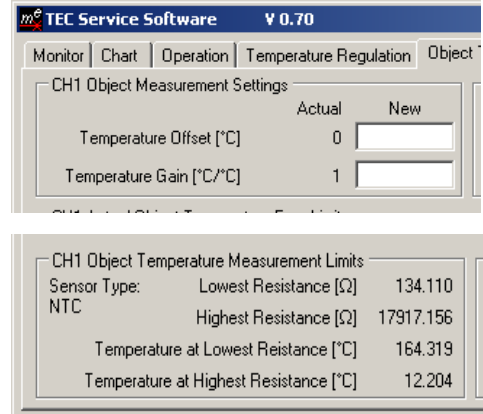

### Step 15 Set Object Temperature Safety / Plausibility Data

- Locate CH1 Actual Object Temperature Error Limits

□ Check that reasonable error threshold values are set

← Max Temp Change is a parameter needed for the identification of physically non-plausible changes in object temperature, such as they occur for faulty temperature sensors, or if elements contributing to the system's thermal inertia have dislodged.

The evolution of the object temperature is constantly monitored. If a step (steep slope, jump, or drop) in object temperature, faster than the 'Max Temp Change' rate occurs, the unit will go into error status.

The TEC controller is immune to noise transients (shorter than 300ms) in the object temperature acquisition circuitry.

← The lower and upper thresholds are safety limits. If the measured object temperature falls outside them, the TEC controller will enter error status and switch off its outputs. Again, these safety limits are immune to noise transients.

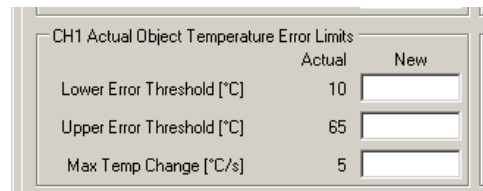

Step 16

**[optional] Enter CH1 Object NTC Sensor Characteristics (e.g. NTC B<sub>25/100</sub> 3988K, R<sub>25</sub> 10k)**

- Locate CH1 Object NTC Sensor Characteristics

□ *In case a PTC sensor (Pt100, Pt1000) was chosen to acquire object temperature, its characteristics according to DIN EN 60751 are used (internally saved)*

□ *In case an NTC sensor was chosen to acquire object temperature, please take the time to check/enter its characteristics*

← Sensor (thermistor) characteristics are modeled according to the Steinhart-Hart equation

← Factory settings for default NTC object temperature probe (NTC B<sub>25/100</sub> 3988 10k, linearization range 0-60°C)

← In case a different NTC object temperature probe is used, the values in 'CH1 Object NTC Sensor Characteristics' must be filled in

← Please refer to chapter 7.2 for information on entering NTC characteristics

		Actual	New
Lower Point	Temperature [°C]	0	<input type="text"/>
	Resistance [Ω]	32650	<input type="text"/>
Middle Point	Temperature [°C]	25	<input type="text"/>
	Resistance [Ω]	10000	<input type="text"/>
Upper Point	Temperature [°C]	60	<input type="text"/>
	Resistance [Ω]	2488	<input type="text"/>

Step 17

**[factory-set] Sink Temperature Measurement Bypassing**

- Switch to Tab6 'Sink Temperature'
- Locate CH1 Sink Temperature Source Selection

□ *Check that a realistic 'Fixed Value' is chosen as sink temperature*

← Monitoring the temperature at the heat sink side of a Peltier element allows for optimized power modeling. If this is not required, a fixed sink temperature can be assumed

← If heat sink temperature monitoring is required, a sensor must be connected and configured prior to activation, otherwise out-of-range errors will be produced

		Actual	New
Sink Temperature Selection	Fixed Value		<input type="text"/>
Fixed Temperature [°C]	25		<input type="text"/>

**[optional] Check CH1 Sink Measurement Settings**

- Switch to Tab6 'Sink Temperature'

□ Please note that the user interface for sink temperature measurement configuration and operation is very similar to the one for object temperature configuration

← Sink temperature measurement uses an MCU-integrated 12bit ADC

← Acquisition circuitry can only accommodate NTC type sensors

\* Temperature Offset and Gain are user-settable calibration values for sensor calibration

\* Error Thresholds are safety settings, Max Temp Change is plausibility data

\* Sink NTC Sensor Characteristics are always relevant (i.e. they cannot be superseded by Pt100/Pt1000 internal data)

← Sensor type indication at bottom of current tab

\* NTC characteristics are defined by three [temperature, resistance] points extracted from the sensor's data sheet

← Current factory settings: NTC B25/100 3988 10k, 0-60°C

\* Sink Temperature Selection and Fixed Temperature allow sensor bypassing

← Currently, external Sink Temperature Measurement is not active and the Fixed Value of 25°C is fed to the system.

← See chapter 6 for more information on Object and Sink Temperature Measurement

TEC Service Software		V 0.70		
Monitor	Chart	Operation	Temperature Regulation	Object
CH1 Sink Measurement Settings				
		Actual	New	
Temperature Offset [°C]		0	<input type="text"/>	
Temperature Gain [°C/°C]		1	<input type="text"/>	
CH1 Actual Sink Temperature Error Limits				
		Actual	New	
Lower Error Threshold [°C]		5	<input type="text"/>	
Upper Error Threshold [°C]		70	<input type="text"/>	
Max Temp Change [°C/s]		5	<input type="text"/>	
CH1 Sink NTC Sensor Characteristics				
		Actual	New	
Lower Point	Temperature [°C]	0	<input type="text"/>	
	Resistance [Ω]	32650	<input type="text"/>	
Middle Point	Temperature [°C]	25	<input type="text"/>	
	Resistance [Ω]	10000	<input type="text"/>	
Upper Point	Temperature [°C]	60	<input type="text"/>	
	Resistance [Ω]	2488	<input type="text"/>	
CH1 Sink Temperature Source Selection				
		Actual	New	
Sink Temperature Selection		External	<input type="text"/>	
Fixed Temperature [°C]		25	<input type="text"/>	
CH1 Sink Temperature Measurement Limits				
Sensor Type:	Lowest Resistance [Ω]	50.161		
NTC	Highest Resistance [Ω]	49780.516		
	Temperature at Lowest Resistance [°C]	214.560		
	Temperature at Highest Resistance [°C]	-8.053		

## 4.7 Object (and Sink) Temperature Acquisition

- Step 19 [case 1: factory-selected NTC probes] **Have Temperature Probes Assembly at Hand**
- Proceed as follows if you wish to use factory-selected NTC probes for object (and sink) temperature acquisition: NTC B<sub>25/100</sub> 3988K, R<sub>25</sub> 10k
- Make sure temperature probe(s) on cable and plug are assembled according to Figure 1 (TEC-1089-based) or Figure 2 (TEC-1122-based)
- Make sure temperature measurement settings are entered according to Step 16 (object) and Step 18 (sink)

- Step 20 [case 2: factory-set Pt100 or Pt1000 probes] **Have Temperature Probes Assembly at Hand**
- Proceed as follows if you wish to use Pt100 or Pt1000 probes for object temperature acquisition. (Factory-selected sink temperature sensor: NTC B<sub>25/100</sub> 3988K, R<sub>25</sub> 10k)
- Make sure temperature probe(s) on cable and plug are assembled according to Figure 1 (TEC-1089-based) or Figure 2 (TEC-1122-based)
- Check Pt100 or Pt1000 is the 'Sensor Type' displayed at the bottom of Tab5

- Step 21 [case 3: own choice of probes] **Select RTD Model, Fabricate Assembly**
- Please proceed as follows if you wish use self-chosen RTD probes for object (and sink) temperature acquisition
- Chose an RTD type/model (Pt100, Pt1000, NTC) to sense temperature at the object
- ← Refer to chapter 7.1 for brief information on sensor operation, choice and linearization
- Optionally, chose an NTC model to sense temperature at the heat sink
- ← Please contact Meerstetter Engineering if you want to use any sensor other than the ones covered in Table E
- Identify the required value(s) of the reference resistors(s) R<sub>s</sub> and replace it(them) according to Figure 1 (TEC-1089-based) or Figure 2 (TEC-1122-based)
- Assemble temperature probe(s) on cable and plug according to Figure 1 or Figure 2, and chapter 7.4

- Step 22 **Connect Temperature Probes Assembly**
- Locate temperature probes socket X7 and plug in assembly
- 'Object Temperature' (CH1, Tab1) should now indicate a reasonable, slightly fluctuating value
- Also, the primary sensor's resistance should be displayed in 'Object Sensor Resistance'
- 'Sink Temperature' will still be static

- Step 23 [optional] **Enable Sink Temperature Monitoring**
- Set 'Sink Temperature Selection' to 'External' (Tab6)
  - Press the 'Write Config' button in the lower right corner
- ← Measurement of the sink temperature will improve the performance of the integrated Peltier element power optimization routine (see Step 24)

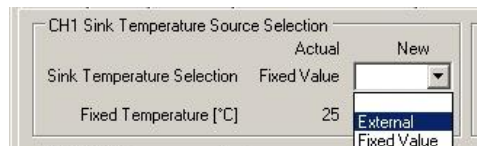

- 'Sink Temperature' (Tab1) will now be dynamic. Check the value is reasonable

## 4.8 Connection of a Peltier Element

### Step 24 Chose Peltier Element and Enter Specific Characteristics

- Find the four parameters Maximal Current, Maximal Voltage, Cooling Capacity and Maximal Delta Temperature in your Peltier element's data sheet
- Enter these values into the fields provided (Tab4)
- Save by clicking 'Write Config'
- Later, you may use the dropdown menu 'Positive Current is' to match the polarity of the connected Peltier element (see Step 28)
- For driving an ohmic heater ('Resistor, Heat Only' mode, see Step 32), enter its resistance and maximal current in the fields provided

← As the cooling and heating characteristics of Peltier elements are not symmetric in respect to the injected current, all TEC-Family Peltier controllers feature integrated power optimization routines based on a power balance model

← Peltier element characteristics are needed for the extraction of model parameters that are used to calculate the 'Thermal Power Model Current' (Tab1) for temperature regulation / control

CH1 Peltier Characteristics		
	Actual	New
Maximal Current [A]	15	<input type="text"/>
Maximal Voltage [V]	15.4	<input type="text"/>
Cooling Capacity Qmax [W]	130	<input type="text"/>
Delta Temp dTmax [°C]	68	<input type="text"/>
Positive Current is	Heating	<input type="text"/>

CH1 Resistor Characteristics		
	Actual	New
Resistance [Ω]	1.65	<input type="text"/>
Maximal Current [A]	10	<input type="text"/>

### Step 25 Limit TEC Controller Power Output According to Peltier Element Chosen

- Make sure the CH1 current limitation (Tab3) does not exceed the Peltier element's maximal current (Tab4) rating [*this is important, as the Service Software does not check this*]
- Set the voltage limitation roughly 1 V higher than the Peltier element's maximum voltage rating (compensate losses in cables)
- Set the corresponding error thresholds approx. 20% higher than the limitation values (rule of thumb)

CH1 Limits		
	Actual	New
Current Limitation [A]	5	<input type="text" value="10"/>
Voltage Limitation [V]	16	<input type="text" value="13.7"/>
Current Error Threshold [A]	6	<input type="text" value="12.6"/>
Voltage Error Threshold [V]	19	<input type="text" value="16.4"/>

Step 26

**Prepare TEC Controller for Connecting Peltier Element to CH1**

- Make sure object temperature measurement is working (Tab1)
- Make sure 'Static Current/Voltage' is the control input to the CH1 output stage (Tab3)
- Make sure 'Set Current\*\* [A]' reads 1
- Make sure 'Output Enable' is disabled ('Static OFF')
- [+Write Config]
- Switch off TEC controller's power supply

Step 27

**Connect Peltier Element to TEC Controller CH1**

- Locate TEC power output terminals X5 and X6 (TEC-1089-based: Figure 1, TEC-1122-based: Figure 2)
- Connect one terminal of the Peltier element to X5 (OUT+) and the other to X6 (OUT-)

← The Peltier element now may or may not be connected correctly. Polarity will be checked in the next steps

Step 28

**Check Peltier Element Connection Polarity**

- You want to determine whether a current defined as positive (from OUT+ to OUT-) heats or cools the object
- Power up TEC controller
- Enable output by toggling 'Static ON' [+Write Config]
- Check actual output current (Tab1 'Monitor') is 1A as set in Step 26
- Observe object temperature (Tab1 or Tab2)

□ If the object temperature rises, the Peltier element is heating and thus connected as defined by the default setting in Tab4

□ If the object temperature sinks, the Peltier element is cooled by a positive current. The polarity needs to be inverted, either by manipulating hardware or software. For hardware inversion: disable output or switch off TEC controller and go back to Step 27, exchanging the cables between X5 and X6. For software inversion: change definition 'Positive Current is' in Tab4.

← Correct polarity is essential for the TEC controller to be able to work as a temperature controller

Step 29

**[optional] Disable TEC Output Stages**

- Change 'Output Enable' to 'Static OFF' [TEC-1122-based: for both channels]
- Write Config

← This switches channel outputs off. With all channels disabled, the TEC controller is in 'Ready' status

## 4.9 Temperature Regulation / Digital Temperature Control

### Step 30 Prepare TEC as Temperature Controller: Enter PID (Starting) Values

- Open Tab4 'Temperature Control'
- Enter PID starting values as suggested

← The proportional term  $K_p$  defines the portion [%] of normalized cooling/heating power that can be used to correct the difference [°C] between actual and nominal temperature

← The integral term  $T_i$  defines the reset time [s] the regulator is allowed to take for correcting a given control deviation. The effect of  $T_i$  is weak for large values and strong for small values

← The derivative term  $T_d$  opposes changes in control deviation, weighed by unit time [s]. The dampening effect of  $T_d$  increases with larger values. (By default the D component is bypassed)

← The suggested PID values are starting values that proved to work reasonably well at factory. At a later stage, they need to be optimized for a given application and system. This can e.g. be done from within Service Software Tab7 'Auto Tuning' (see chapter 5.4)

CH1 Temperature Controller PID Values		
	Actual	New
$K_p$ [%/°C]	10	<input type="text"/>
$T_i$ [s]	300	<input type="text"/>
$T_d$ [s]	0	<input type="text"/>

### Step 31 Prepare TEC as Temperature Controller: Enter Target Temperature and Ramp

- In 'CH1 Nominal Temperature' enter a target object temperature of choice (e.g. 25°C)
- Enter values for coarse temperature ramp as well as proximity width

← If important thermal masses are involved, a system's response to changes in cooling/heating power and thus the establishment of thermal stability may be very slow.

At power-up, large changes from an initial to a target object temperature can be required. In order to minimize overall time to thermal stability, intelligent ramp 'generation' replaces the sudden jump in nominal temperature by a three-part curved ramp.

Nominal temperature is smoothly guided away from the starting value in a sine-shaped curve. It will then leave the 'proximity band' and enter fast, linear transition at the maximum possible rate: 'Coarse Temp Ramp'. Once it is within 'Proximity Width' (default value 1°C) of the target object temperature, a second sine ramp will take over and guide the nominal temperature gently to the target temperature. During that fine ramp phase the system has got more time to thermally stabilize, over/undershoots in respect to the target temperature will be minimized and final temperatures will be stabilize more quickly.

← It is unlikely your system is able to follow the default 'Coarse Temp Ramp' steepness of 1°C/s. (This initial setting allows the user to get a feeling for the system's thermal inertia, and it permits observation of the nominal temperature trace in the graph of Tab2.) Again, you will need to optimize these ramp values for your application and system. This can e.g. be done from within Service Software Tab7 'Auto Tuning' (see chapter 5.4)

← Nominal temperature ramping has been introduced to allow for the use of fairly 'aggressive' PID values, typically required to properly react upon external disturbances. Please note that the ramping and PID parameter sets are independent

CH1 Nominal Temperature		
	Actual	New
Target Object Temp [°C]	25	<input type="text"/>
Coarse Temp Ramp [°C/s]	1	<input type="text"/>
Proximity Width [°C]	1	<input type="text"/>

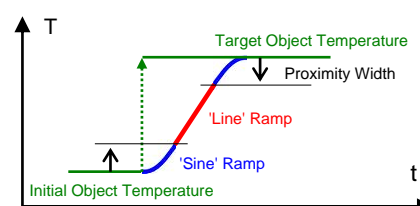

Step 32

**Prepare TEC as Temperature Controller: Check Peltier Element Data and Define Modelization Type**

- Check that Peltier element characteristics (from data sheet) are correct
- Select 'Peltier, Full Control' in the modelization drop-down menu

← Thermal Power Regulation is optimized by modeling the mode and type of device. Peltier elements may be driven in full control, or in heat or cooling only modes. Also, resistive heating may be selected.

Depending on the choice made, either 'CH1 Peltier Characteristics' or 'CH1 Resistor Characteristics' parameters will be implemented (from either of the two group boxes underneath).

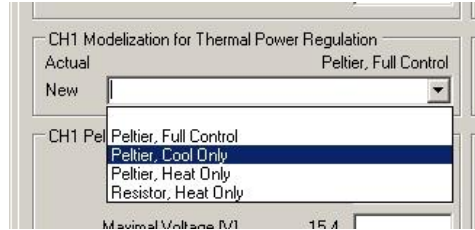

Step 33

**Activate TEC as a Stand-Alone Temperature Controller**

- In Tab3 'Operation', change 'CH1 Output Stage Control Input Selection' to 'Temperature Controller'
- Change 'CH1 Output Stage Enable' to 'Static ON'
- Immediately observe system behavior in Tab1 'Monitor', later in Tab2 'Chart'

- *If object temperature is different from the set target temperature, observe (ramp) nominal object temperature being brought from starting temperature to target*
- *See object temperature attempting to follow nominal temperature and moving toward target temperature, driven by 'Thermal Power Model Current' (default definition: positive for heating, negative for cooling)*
- *Observe 'PID Control Variable [%]' being large for large discrepancies between object temperature and (ramp) nominal temperature, and vice-versa being little for small differences*
- *Find a way to quantify/judge system behavior (e.g. coarse response time, overshoot and final stability), compare it with your needs and try to optimize PID values and ramping parameters [Tab4] or use the auto tune functionality [Tab7].*

← The three bottom group boxes in Tab1 are for monitoring purposes only:  
\* 'CH1 Output Stage Monitoring' displays the internal hardware current measurement feeding back into the regulation circuit  
\* 'CH1 Temperature Controller PID Status' displays normalized thermal power control and its limits due to actual situation  
\* 'CH1 Temperature Measurement' shows raw sensor data prior to conversion as well as corresponding sensor resistance

← The elements of Tab2 'Chart' are briefly described in chapter 5.1  
← The elements of Tab7 'Auto Tune' are briefly described in chapter 5.4

## 5 Advanced Operation

### 5.1 Charting and Data Logging

Tab 'Chart' offers a convenient way of mid-term system characterization, e.g. for observing stability, or for optimizing PID control or nominal temperature ramping parameters.

Object temperature(s) and their nominal values [thin lines] are shown in the top panel, output current(s) and PID control variable magnitude(s) are shown in the bottom panel.

Curves are shown/hidden according to the tick boxes to the right, all vertical axis can be scaled manually or automatically. The time axis unit is minutes ('General Settings, Chart Area') and the chart can be chosen to scroll. To display the full chart history (since last start of the Service Software), click on the small clock symbol at the left side of the bottom time axis (see Figure 4).

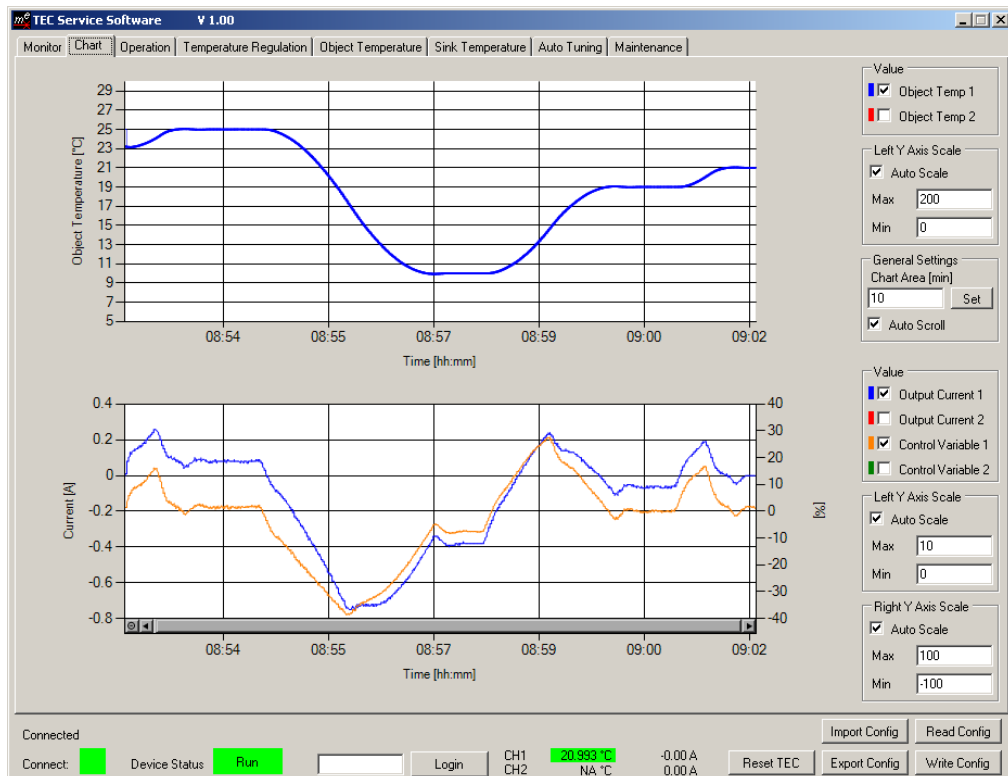

Figure 4. Chart tab with panels for object temperature (top) and output current / PID control variables (bottom). Curves can be shown/hidden and axis scaled manually/automatically. Nominal object temperatures are shown as thinner lines but in the same color as actual object temperatures (top panel).

Starting from Service Software version 1.00, the logged data can be exported to a .csv file for external plotting and detailed analysis. The logging interval is set in Tab 'Maintenance', next to the current number of log entries displayed. Each log entry is time-stamped. At (re)launch of the software, the log is erased and the logging interval is reset to the smallest permitted value of 1 s. Whereas the graph recording time at a fixed rate is limited to 6h, the logging duration is not restricted. The maximum logging time is a function of the available RAM and the logging interval. For critical long term monitoring it is recommended to export the log regularly, and to re-launch the Service Software occasionally (e.g. once every couple of days).

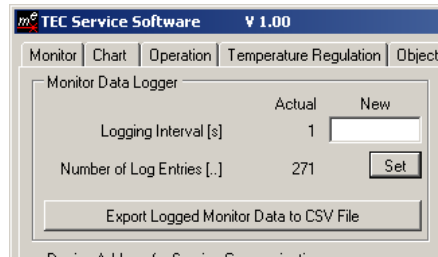

Figure 5. 'Monitor Data Logger' in Tab 'Maintenance' for setting up logging frequency, consulting the current number of time points recorded, and for saving the time-stamped log file in .csv format.

At export of the logged monitor data, all data displayed in Tab 'Chart' (Object Temperature, Actual Output Current, PID Control Variable) is saved as comma-separated values. Additionally, Sink Temperature, Target Object Temperature, (Ramp) Nominal Temperature, Thermal Power Model Current and Actual Output Voltage, as displayed in Tab 'Monitor', is saved for CH1 and CH2. Finally, the system values Driver Input Voltage and Base Plate Temperature are exported, as well.

## 5.2 Temperature Stability Indication

When a TEC channel is operated as temperature controller, the channel's actual temperature displayed in the status bar at the bottom of the Service Software window is highlighted in amber. The user is visually informed once temperature stability is reached: the indication turns green. This is particularly helpful at system warm-up or following an important change in target temperature, when operation of equipment has to be prohibited until a thermal steady-state is reached. In addition, stability indication also alarms the user about problems occurring during constant operating conditions.

NB. The status of the temperature stability indicator is also available for remote (RS485/USB) operation. Please refer to the document number 5136 on the TEC-Family communication protocol

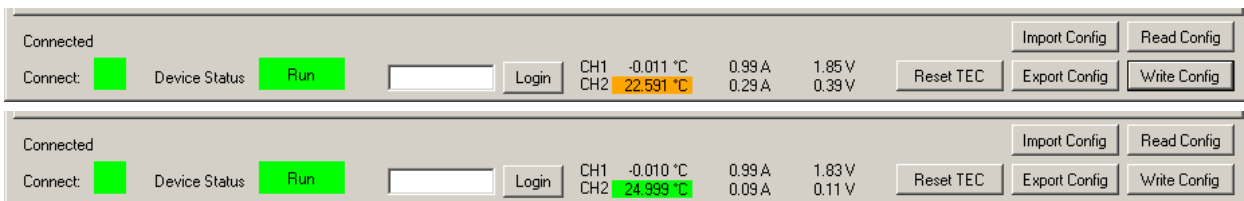

Figure 6. Service Software status bar with the actual object temperature highlighted while a channel is operated as temperature controller. The highlight color turns from amber to green once stability conditions are met.

Temperature stability criteria are user-defined and consist of a temperature range and a time frame. They are entered into 'CH1 Object Temperature Stability Indicator Settings' in Tab 'Object Temperature'. For actual object temperature judged to be stable, it must have been within 'Temperature Window' of target object temperature for 'Min Time in Windows' or more. This means that if actual object temperature falls out of 'Temperature Window', stability indication is immediately lost (and will return the earliest after the delay of 'Min Time in Windows').

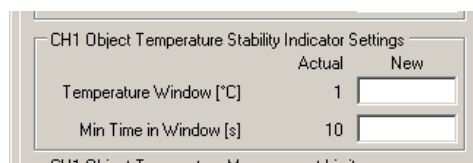
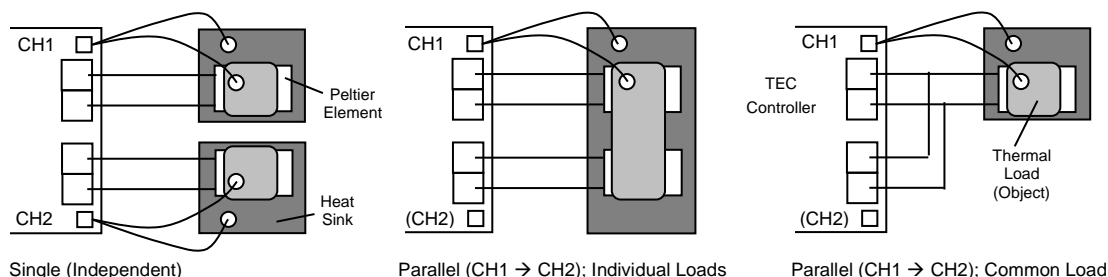

Figure 7. 'CH1 Object Temperature Stability Indicator Settings' group box in Tab 'Object Temperature'. The user can set temperature and time requirements that need to be met before stable temperature is indicated in the status bar.

## 5.3 Two Channel Operation and Parallel Mode Selection

In Tab 'Operation', the general operating mode can be changed from the default 'Single (Independent)' setting:

- For TEC-1122-based devices, a 'Parallel (CH1 → CH2); Individual Loads' mode can be selected. In that mode the output current and output voltage values of channel 2 are set to the ones currently active for channel 1. The 'CH1 Output Stage Enable' status is also valid for both channels. However the output stage limits defined for each individual channel remain independent.  
In practice, this means that the CH2 output stage will follow the values defined by the selected CH1 Output Stage Control Input – as long as it satisfies its own limits.
- For current doubling, the outputs of the two channels are connected to one common load (see below). In 'Parallel (CH1 → CH2); Common Load' mode, and if CH1 is working as 'Temperature Controller', the PID controller is aware it can dispose over twice the nominal current, to which each channel will provide an equal amount.  
The CH1 + CH2 total output current is indicated in 'Parallel Output Stage Monitoring (Common Load)' in Tab 'Monitor'.
- A general note for parallel mode operation: As each channel / device is able of bipolar voltage and current swings, they must not run into voltage limitation when their output are connected in parallel. Voltage limitation may lead to important compensation currents, in particular if the connected common load cannot conduct all current generated. Therefore, voltage limits must be set to maximum permissible values, and current limits should be set such that each channel / device runs into current limitation instead of voltage limitation.



## 5.4 Auto Tuning / System Optimization

Meerstetter Engineering provides their customers with an auxiliary tool that facilitates the determination of PID controller and ramping parameter sets in the Service Software Tab 'Auto Tuning'.

This tool is designed help with system optimization. However, it cannot be guaranteed that the implemented algorithms yield a result. Therefore, final responsibility for the settings chosen lies with the end user.

The implemented PID parameter system is briefly described in Step 30, nominal temperature ramp generation is described in Step 31. Refer to literature on control engineering for more general descriptions of systematic optimization procedures.

In Tab 'Auto Tuning', a tool to tune the PID values is provided. Its operation is self-explanatory:

- Make sure your object temperature acquisition circuitry works reliably and your thermoelectric cooling / Peltier element is connected in the right polarity.
- Optionally, have your sink temperature acquisition circuitry activated.
- Peltier Characteristics (Tab 'Temperature Control') and temperature limits must be set correctly.
- The TEC channel is already being successfully operated as 'Temperature Controller', and the target object temperature lies in the range relevant to your application.
- Before tuning, it is recommended to export the current device configuration, or to note the current 'CH1 Temperature Controller PID Values' (Tab 'Temperature Control') as well as the ramping/proximity parameters from 'CH1 Nominal Temperature'.

Continue the procedure:

- During the tuning process, no heating / cooling source other than the driven Peltier element must be active.
- Select the TEC Instance you want to tune. For TEC-1089-based devices, this will be CH1. For TEC-1122-based devices, this can either be CH1 or CH2.
- In the status box, some red text may appear: "Please set 'Output Stage Control Input Selection' to 'Temperature Controller'." Auto tuning will not work if the output stage is operated as DC power supply with static or live current/voltage parameters. This message may be followed by "Please set 'Output Enable' to 'Live OFF/ON'." Auto tuning does not allow the output stage to be enabled/disabled statically. In 'Live OFF/ON' status, the power output of the selected channel will be enabled during tuning and then disabled afterwards.
- The status indicator read 'Idle. Press Start to Tune!'. Press the 'Start' button: the driver enters 'Run' status and begins 'Ramping to Target Temperature...'. NB. The 'Stop' can be pressed at any time to abort the tuning process.
- Once the target temperature is reached, the Peltier controller initiates a cooling/heating pattern that will reveal specific system information. The progress of the Auto Tuning procedure is indicated by the advancing status bar, and will go through steps of preparation, acquisition and completion. NB. During auto tuning, the user can observe the applied current patterns and resulting temperature variations in Tab 'Charts'.
- Upon 'Success. Tuning Complete!' the TEC driver returns to 'Ready' status.
- The PID tuning results Kp, Ti and Td are displayed and the user can chose to accept these new settings by clicking 'Write Auto Tuning Results to TEC'.
- The other set of parameters than can be selected to become active is the 'Nominal Temperature Ramping Recommendation' (see Step 31). Therefore, the corresponding box needs to be ticked (default) before writing the auto tuning results to the device.
- Again, it is the responsibility of the user to adopt or discard auto tuning results
- The auto tuning tool is implemented in the TEC firmware and can be accessed during local (Service Software) or remote (RS485/USB) operation.

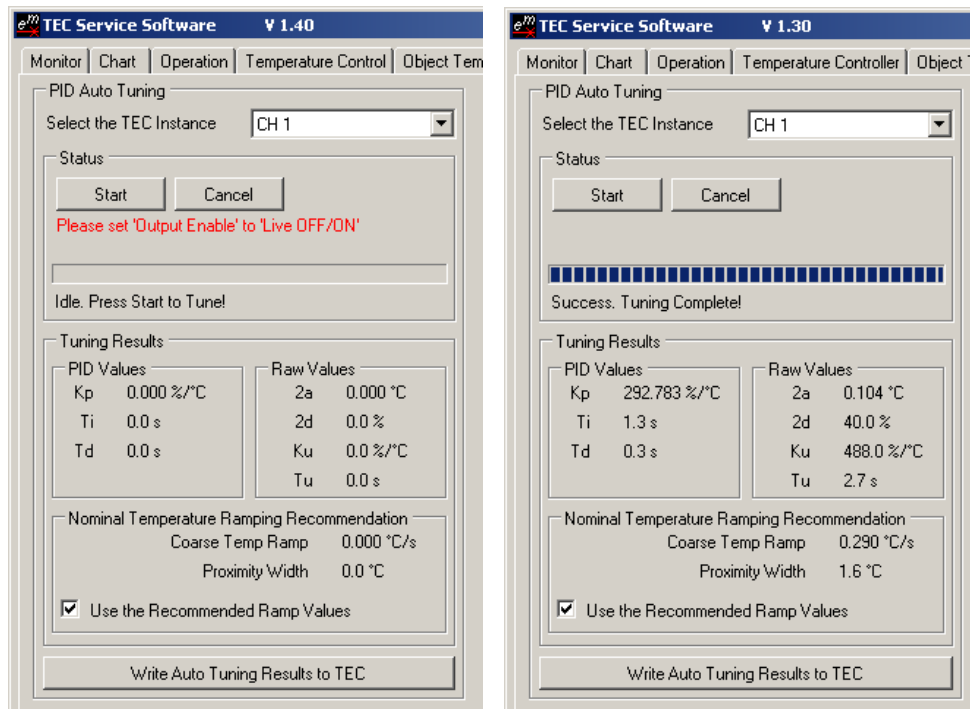

Figure 8. PID Auto Tuning control interface allowing the user to apply an optimized set of PID values and recommended nominal temperature ramping [optionally].

## 5.5 Configurations and Parameter Activation

### Reading Configuration Parameters from the Device

When establishing a connection with the TEC controller, the Service Software reads all current device settings

(The current settings can also loaded manually by clicking the 'Read Config' button).

### Writing Configuration Parameters to the Device

If TEC parameters are to be changed from the Service Software, enter the new values into the fields provided. If any entered parameter falls outside the permitted range, the field will be highlighted in red.

To transfer the data to the TEC controller's memory, press the 'Write Config' button. Any out-of-range parameter will automatically be restricted it to its minimal or maximal limit.

Saving parameters to the device's configuration flash can take some time. To allow a writing process to finish, please wait 3 s before powering down the TEC or rewriting new data.

Please note that several fields can be written at once. Actually, all the non-empty field values are written to the TEC controller, including the ones not visible in the foremost tab. Be aware that leaving fields non-empty when switching between tabs may cause accidental misconfiguration.

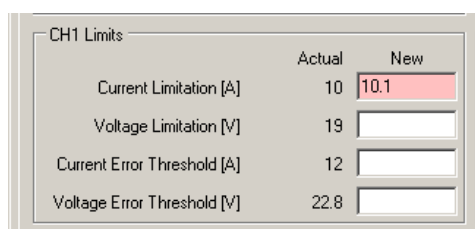

	Actual	New
Current Limitation [A]	10	10.1
Voltage Limitation [V]	19	
Current Error Threshold [A]	12	
Voltage Error Threshold [V]	22.8	

Figure 9. Any parameter entered are checked for validity by the Service Software. Out-of-range values are highlighted and restricted upon pressing 'Write Config', if necessary.

### Reset-Parameters

Most of the configuration parameters become effective immediately after the 'Write Config' command has been issued. Typically, these are settings related to the real-time operation of the TEC controller (such as current / voltage set, PID values, temperature target and ramp, etc.).

On the other hand, there are settings that will only come into operation once the TEC has been power-cycled or reset (even though the Service Software will state them as actual). Generally, these *reset-parameters* are settings related to system/hardware properties that do not change frequently (such as RS485 communication and object temperature measurement ADC settings).

Reset-parameters are highlighted with a star (\*) next to their designation in the Service Software. Please refer to **Fehler! Verweisquelle konnte nicht gefunden werden.** for identification of all reset-parameters.



Figure 10. For reset-parameters to become activate, the unit needs to be power-cycled or reset by pressing 'Reset TEC' in the bottom right corner of the Service Software.

## 5.6 Device Configurations Handling

### Importing and Exporting .ini Configuration Files

TEC controller configuration sets can be backed up as .ini files. They are device-specific, as they contain calibration data. In the Service Software, click on 'Export Config' in the bottom right corner and save the configuration file.

To read configuration sets into a connected TEC controller, click on 'Import Config' in the Service Software and select the .ini configuration file.

There is an important difference between the amount of data written at export and the amount read at import: at export, current device status data (monitor) is also saved, in addition to pure configuration parameters. This device 'snapshot' can be useful for remote support and analysis.

Other types of exported data are calibration values and A/D conversion settings: important, device-specific parameters related to analogue temperature acquisition circuitry. These factory-set parameters are only accessible from the password-protected Tab 'Expert' (see chapter 6 for more information). In that hidden tab, there is a tickbox that prevents overwriting of calibration data during configuration import (by default protected, see chapter 6).

### Settings Dump (\*.mepar File)

For cases where many or all settings are to be changed from a host software or from a host microcontroller, a Settings Dump functionality is available. TEC Service Software is used to generate a file which can be dumped to TEC controllers using third party host systems.

Any information in 'New' fields can be stored to a \*.mepar File, which is a text file where every line contains a parameter string that is specific to function, firmware and device type.

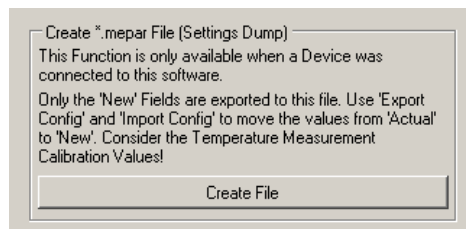

Figure 11. Creation of a \*.mepar File (Tab 'Maintenance') for settings dump by third party host.

Using the communication protocol 'MeCom', this \*.mepar file can be dumped line-by-line to one or several devices. These batch configurations will immediately become active.

It is also possible to download just one single setting (*i.e.* one line of the \*.mepar File) directly from within Service Software to a TEC controller. Therefore, a single mepar string is entered in the field provided and sent.

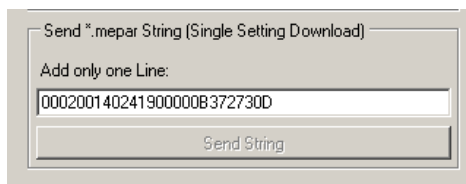

Figure 12. Download and activation of one \*.mepar setting form within Service Software.

## 5.7 Firmware Updates

Before updating the firmware of your TEC controller, backup its current configuration. This is very important because it is possible that the new firmware will have an extended parameter set. By importing the old configuration into a TEC controller with updated firmware, device-specific parameters from the former set are converted and kept.

For the installation of a new firmware, open Tab 'Maintenance'. There are two different Boot Loaders available: 'Device Boot Loader' is integrated into the Service Software and its use is recommended for updating firmware from v0.5 and above. 'STM32 Internal Boot Loader' relies on putting the MCU into boot loader status, quitting the Service Software and using an external software for the transfer. This procedure was required for updating devices with firmware versions 0.1 through 0.41 and is not recommended any longer.

### Firmware Update via Device Boot Loader

Recommended procedure for updating devices with firmware v0.5 and above:

- Back up your TEC's current configuration
- Click on 'Load Hex File'



- Locate the new firmware .hex file (e.g. TEC STM32 v0.80.hex), select and open

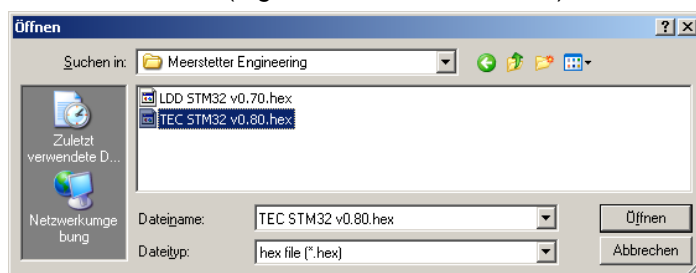

- Click on 'Update Device', the TEC controller will restart once the download complete
- Check the firmware version in Tab 'Monitor'
- Re-import the exported .ini file
- Fill in missing values into new parameter fields, if applicable

## 5.8 Remote Control / Bus Control by Communication Protocol 'MeCom'

TEC-Family devices can be remotely operated over a USB or an RS485 (half-duplex, properly terminated) connection. Depending on hardware, Ethernet communication is available as well. All parameters and status information available via the TEC Service Software can be read or written by either type of remote connection.

In addition, bus-control allows access to live parameters that are stored in volatile memory ('RAM') and that are designed for frequent or fast update (such as bus-controlled temperature curves or enable toggling / interlock).

Full bus-control is accessible over the serial (RS485 / USB / ...) communication protocol 'MeCom'. Live parameters have IDs starting from 50000.

Direct **USB operation** and 'MeCom' communication require no Service Software to be running, and the TEC-Family Peltier controller to appear as a virtual COM port (USB Serial Port) on the PC.

For **RS485 operation** the Channel1 Baud rate and the TEC controller's device address must be specified in Tab 'Operation' (restart required). A response delay can improve compatibility with host hard and software.

RS485 communication is implemented over hardware interface Channel 1, using lines RS485\_A1 and RS485\_B1 (see Figure 1 / Figure 2). Interface Channel 2 is currently reserved for service communication with TEC/LDD Service Software (see chapter 5.9)

The RS485 lines are part of the Platform Bus that allows connecting one or several TEC-1089 or TEC-1122-based Peltier controllers as well as one or several LDD-1121-based laser diode drivers to a common control system. The various devices are identified by individual device addresses, starting from 1 up to 254. 0 and 255 are broadcast addresses to all devices on the bus.

**Ethernet operation** requires additional hardware, such as the LTR-1200 Rack Enclosure with HMI.

The 'MeCom' communication protocol is not covered in this manual. Please refer to documents 5117 [general] and 5136 [TEC-Family-specific]. Feel free to contact Meerstetter Engineering if you require the implementation of a customized protocol.

	USB	RS485 (Channel 1)	Ethernet	RS485 (Channel 2)
MeCom	✓	✓	✓*	not recommended
Service SW	✓	-	✓*	✓

*Table B. Compatibility chart of currently available protocols and TEC data interfaces.*

*\*Additional Ethernet hardware required.*

## 5.9 Remote Control / Service Communication by TEC Service Software

TEC Service Software can address one TEC controller, even if several devices share a single communication interface. It is also possible, to have one or several LDD-Family laser diode drivers connected to that same bus, and to control them by LDD Service Software. These functionalities can be used as stand-alone, or as complement to an existing 'MeCom' control implementation.

### Starting the Service Software with Application Arguments

Further below, three possibilities of connecting to a specific device over a specific interface are described. These settings are volatile and need to be reentered every time the TEC Service Software is launched. Starting the software with application arguments allows to directly load the desired communication settings.

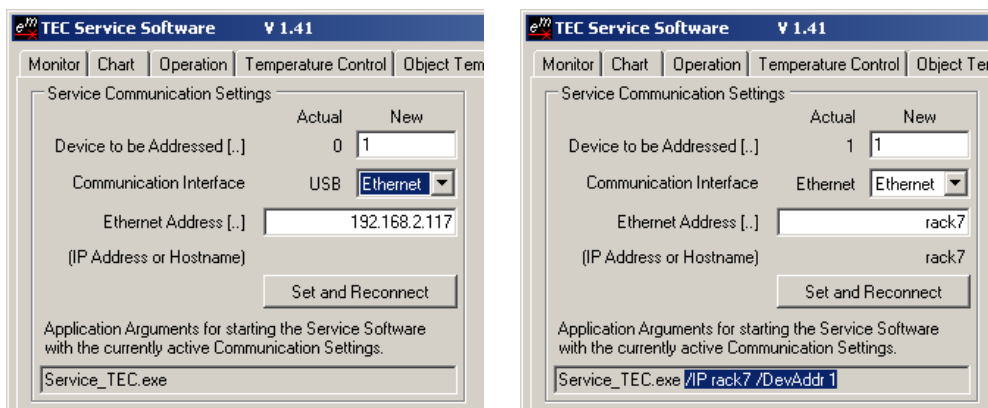

Figure 13. Service Communication Settings (Tab 'Maintenance'). USB/RS485 and Ethernet serial communication interfaces can be chosen, and individual devices on the bus can be addressed directly.

A very convenient way of saving a given configuration is to create a link to the TEC Service Software, to rename it, and to show its properties.

Copy the applications arguments – that's the information following the name of the application – displayed at the bottom of the group box (Service SW). Then paste them at the end of the 'Target:' path in the link's properties (Windows).

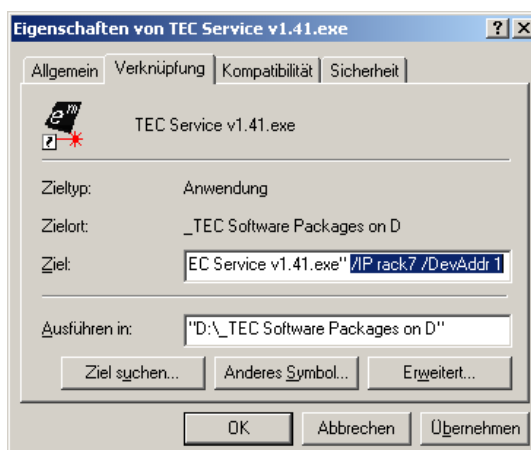

Figure 14. Creation of a customized link to a copy of TEC Service Software that will start up fully configured thanks to added application arguments.

## Bus Operation and Device Addresses

On a bus, each device must have a unique identification (Tab 'Operation'). TEC- and LDD-Family devices can be mixed at leisure; unique addresses may range from 1 to 254 (0 and 255 are reserved: all devices respond to calls on these broadcast addresses).

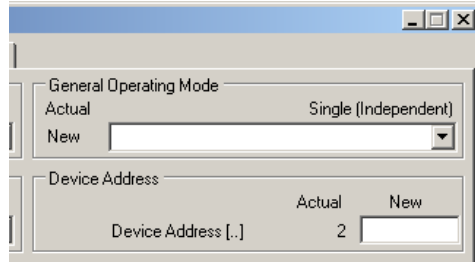

Figure 15. Device Address for bus operation. The factory-set value for TEC-Family devices is 2 (default for LDDs: 1), but any value between 1 and 254 is permitted.

The device address is saved into the TEC controller's nonvolatile memory. The volatile 'Device to be Addressed' setting (Tab 'Maintenance', see Figure 13) needs to match that ID for the service software to communicate with the device.

## Service Communication over USB

This is the way, the initial connection with your TEC controller had been established and that was used for the step-by-step instructions. USB is the 'Communication Interface' selection at startup, and 'Device to be Addressed' = 0 makes all devices on the bus respond.

In more complex settings, e.g. with several Peltier controllers connected via the HMI of an LTR-1200 Rack Enclosure, one single USB cable can still be used for connection, but all devices must have unique addresses.

## Service Communication over Ethernet

For Ethernet to work, the device providing connection to the network (e.g. the HMI of an LTR-1200 Rack Enclosure) must be configured correctly (IP Address, Subnet Mask, Gateway, etc., see device's manual). In 'Service Communication Settings' (Tab 'Maintenance'), Ethernet is activated and an IP Address or Hostname is set. Upon 'Set and Reconnect', the connection will be established and displayed as shown in Figure 13.

As described above, the application arguments matching the currently valid communication will also be indicated.

## Service Communication over RS485 (CH2) and Assembly of a USB-RS485 Converter Cable

Thirdly, a service communication alternative is implemented over RS485 Channel 2 on the platform bus.

A very convenient way for creating an RS485 connection is to use a serial converter cable driven by USB. Customers must use cables available on: <http://www.ftdichip.com/Products/Cables/USBRS485.htm> for full compatibility with Meerstetter TEC and LDD Service Softwares.

The wire-ended FTDI cable USB-RS485-WE-1800-BT (example) is configured to connect to a platform bus in the following manner:

	10-POL DIN 41651 TEC-1089-based TEC controllers	14-POL TYCO 8-215083-4 TEC-1122-based TEC controllers LDD-1121-based laser diode drivers
FTDI Cable Wire 1: GND [black]	Platform Bus Pin 2: GND	Platform Bus Pin 10: GND
FTDI Cable Wire 5: Data+ (A) [orange]	Platform Bus Pin 5: RS485_A2	Platform Bus Pin 13: RS485_A2
FTDI Cable Wire 2: Data- (B) [yellow]	Platform Bus Pin 6: RS485_B2	Platform Bus Pin 14: RS485_B2

Table C. Assembly instructions for USB-RS485 converter cables connecting to the 10- or 14-pol platform busses of Meerstetter TEC-Family and LDD-Family devices.

## Resolution of Address Conflicts by Remote Setting of Device Addresses

If several devices are attached to one same communication bus, but are not addressable, e.g. due to either address conflict, TEC Service Software allows to change one particular device's address. That device is selected according to its Serial Number and Device Type. A 'Set Address' command is broadcast to all devices on the bus, and the device that matches type and S/N will accept it. For that procedure, all other active Service Software functions are temporarily suspended:

- Enable 'Set Address' functionality by ticking the box shown below (All fields are still grayed out)

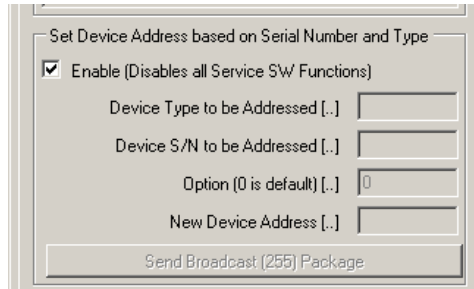

- Press 'Reset TEC' in the bottom right corner of the Service Software
- Service Software confirms its suspend status

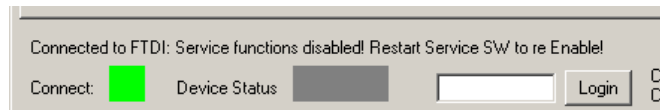

- Fill in all four fields (possible TEC device types are 1089, 1090, 1122, 1123)
- Press 'Send Broadcast (255) Package'

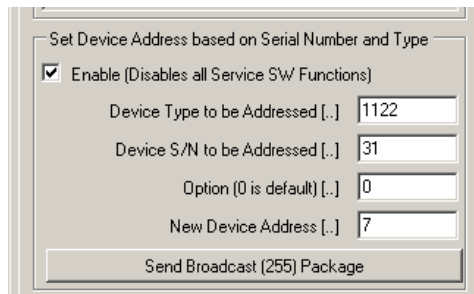

- Restart TEC Service Software

Please refer to the TEC Controller Communication Protocol Specifications (Document 5136) for further information.

## 6 Scriptable Control by Lookup Table Processing (Expert Operation)

Under normal operating modes, all TEC controller settings and parameters are stored in non-volatile Flash memory. In particular, when Target Object Temperature is changed, the new value is stored and the TEC controller internally generates a nominal value ramp. This ramp can be parameterized to a certain extent, but the user does not have precise control over the shape of the ramp. For certain expert applications, full ramp control may be necessary and could be achieved by continuously sending new target temperature values to the device, which would eventually result in Flash memory failure.

Starting from Firmware 1.20, all TEC Controllers are capable of storing a volatile target temperature parameter in 'RAM'. This parameter is not accessible from within the TEC Service Software but can be written to via the TEC-Family Communication Protocol as described in Document 5136.

Also starting from Firmware 1.20, TEC-Family devices can interpret a script language, in which ramps, holds and loops can be defined. Therefore, a Lookup Table is defined in an external editor. It is then (once) transferred into the TEC controller's Flash memory and portions of it are called / read into the TEC's volatile memory during run-time.

Lookup Table processing is fully controllable over the Communication Protocol. Typical Operations are sub-table ID selection, number of repetitions, start/stop, status. (Refer to Document 5136 for description and see below chapter for illustration).

### 6.1 Lookup Table Control from within TEC Service Software

From within TEC Service Software, Lookup Table support is accessible while in 'Expert' mode (enter 'expert' into the login field provided to make the Tab 'Lookup Table' visible).

Please make sure that before activating any Lookup Table automation, the Temperature PID Controller is well tuned.

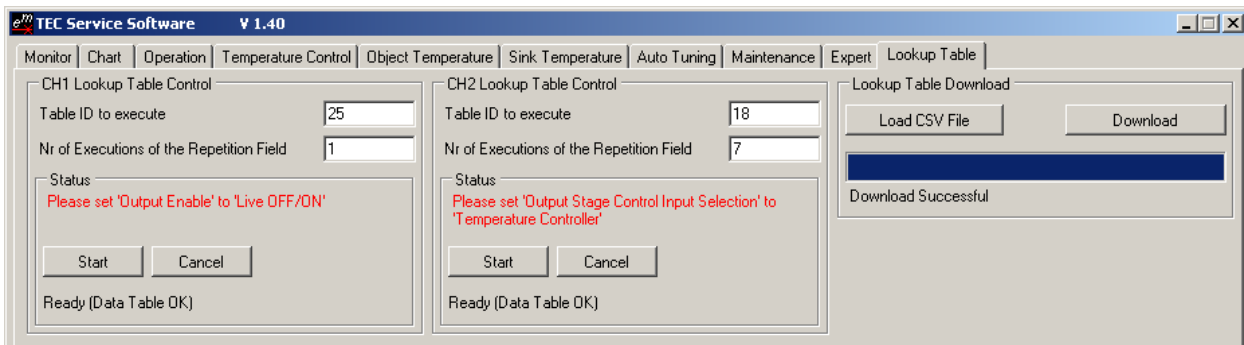

*Figure 16. Tab 'Lookup Table' (expert mode). The table is downloaded as a .csv file, and each TEC controller channel / instance may execute portions of it. All 'Lookup Table' processing functionality provided by the Service Software is also accessible via Communication Protocol.*

Lookup Table Control is available for TEC channels that are operated as Temperature Controllers (*i.e.* not as DC power supplies) according to Tab 'Operation'. Active Lookup Table Control also requires 'CH1 Output Stage Enable' to be 'Live OFF/ON'.

Load the externally generated table into the TEC controller's memory by 'Load CSV File' and 'Download' (please refer to the following sections for Lookup Table generation).

For each TEC channel / instance, select the Table ID and the number of executions of the repetition field. Upon 'Start', Lookup Table Control will ignore/override non-volatile Nominal Temperature settings (group box in Tab 'Temperature Control'). Once all instructions of a selected Lookup Table 'script' have been executed - or when Lookup Table Control is cancelled - the TEC channel returns to its previous state.

## 6.2 Instruction Set and Available Options

The Lookup Table Control scripting language is delivered as lines in a Instruction/Field1/Field2 format. The three elements per line are separated by semicolon, the third element (Field2) is not always used.

*The current Lookup Table instruction set can be extended upon customers' requests.*

Type	Symbol Name / Range	Description
<b>Instruction</b>	<b>TABLE_INFO</b>	Start and End Markers of a defined portion (Sub Table) of the loaded Lookup Table. Table ID is selectable from within TEC Service Software Tab 'Lookup Table'
Field 1 Option	START	Start of Sub Table
Field 1 Option	END	End of Sub Table
Field 2 Value	Range 0+INT32	Table ID (arbitrary identification number, set by user)
<b>Instruction</b>	<b>SIN_RAMP_TO</b>	Standard Sine Ramp
Field 1 Option	FROM_ACT	Ramp from Actual Object Temperature
Field 1 Option	FROM_NOM	Ramp from Latest Target Temperature
Field 2 Value	Range FLOAT32	Target Temperature in °C
<b>Instruction</b>	<b>REPEAT_MARK</b>	Repetition Markers. The instructions between START and END will be repeated a predefined number of times. Nr. of Executions is selectable from within TEC Service Software Tab 'Lookup Table'
Field 1 Option	START	Start of Repetition Field
Field 1 Option	END	End of Repetition Field
<b>Instruction</b>	<b>LIN_RAMP_TIME</b>	Linear Ramp between the Current Target Temperature to the New Target Temperature
Field 1 Value	Range UINT24	Ramp Time in ms (1000 --> 1 second) Resolution 100ms
Field 2 Value	Range FLOAT32	New Target Temperature in °C
<b>Instruction</b>	<b>STATUS</b>	Instruction at the End of a Table
Field 1 Option	DISABLE	Disables the TEC Channel
Field 1 Option	ENABLE	Enables the TEC Channel
<b>Instruction</b>	<b>EOF</b>	
Field 2 Value	CRC	CRC is calculated and inserted by the TEC Service Software
<b>Instruction</b>	<b>WAIT</b>	Wait Instruction
Field 1 Option	FOREVER	Waits here forever (until the system is switched off or the Sub Table execution is cancelled)
Field 1 Option	TIME	Waits the time defined in Field 2
Field 2 Value	Range 0+INT32	Specifies the Wait Time in ms (only if Field 1 Option is TIME)

Figure 17. TEC Lookup Table Instruction Set and Options. Instructions are highlighted in bold, field options spelt in capitals and value range defined as follows:

Range UINT24 0..16777215

Range 0+INT32 0..2147483647

Range FLOAT32 32bit Float according to IEEE754

### 6.3 Example Lookup Table Generation/Editing and Export

The following files are for illustrative purposes only. A basic Lookup Table file can be requested from Meerstetter Engineering.

Instruction	Field 1	Field 2	Description
TABLE_INFO	START	0	The Lookup Table consists of several Sub Tables. This Instruction defines the Start of the Sub Table ID 0
STATUS	ENABLE		This Instruction enables the selected TEC Instance
SIN_RAMP_TO	FROM_ACT	20.5	The TEC will generate a standard sine ramp from the actual Object Temperature to 20.5°C
SIN_RAMP_TO	FROM_NOM	25	The TEC will generate a standard sine ramp from the current Target Temperature (20.5°C) to 20.5°C
STATUS	DISABLE		Disables the TEC Instance
TABLE_INFO	END	0	End of Sub Table ID 0
TABLE_INFO	START	1	Defines the Start of the Sub Table ID 1
STATUS	ENABLE		Enables the TEC Instance
SIN_RAMP_TO	FROM_ACT	22.3	The TEC will generate a standard sine ramp from the actual Object Temperature to 22.3°C
REPEAT_MARK	START		Defines the start of the repetition field. The Instructions between the START and END will be executed a predefined number of times
LIN_RAMP_TIME	12000	25.3	Generates a linear ramp to 25.3°C within 12s
LIN_RAMP_TIME	5000	28.3	Generates a linear ramp from 25.3°C to 28.3°C within 10s
LIN_RAMP_TIME	15000	30.56	Generates a linear ramp from 28.3°C to 30.56°C within 8s
LIN_RAMP_TIME	5000	27	Generates a linear ramp from 30.56°C to 27°C within 15.1s
REPEAT_MARK	END		Defines the End of the repetition field
SIN_RAMP_TO	FROM_NOM	20	Standard sine ramp from 27°C to 20°C
STATUS	DISABLE		Disables the TEC Instance
TABLE_INFO	END	1	End of Sub Table ID 1
TABLE_INFO	START	25	Defines the Start of the Sub Table ID 25
STATUS	ENABLE		Enables the TEC Instance
SIN_RAMP_TO	FROM_ACT	15	The TEC will generate a standard sine ramp from the actual Object Temperature to 15°C

Figure 18. Lookup Table editing in MS Excel. Screenshot showing two Sample Scripts (Table ID 0 and Table ID 1) and the beginning of a third (Table ID 25). The comments in the fourth column are for convenience during editing. They must be deleted before exporting to .csv.

```

Instruction;Field 1;Field 2
TABLE_INFO;START;0
STATUS;ENABLE;
SIN_RAMP_TO;FROM_ACT;20.5
SIN_RAMP_TO;FROM_NOM;25
STATUS;DISABLE;
TABLE_INFO;END;0
TABLE_INFO;START;1
STATUS;ENABLE;
SIN_RAMP_TO;FROM_ACT;22.3
REPEAT_MARK;START;
LIN_RAMP_TIME;12000;25.3
LIN_RAMP_TIME;5000;28.3
LIN_RAMP_TIME;15000;30.56
LIN_RAMP_TIME;5000;27
REPEAT_MARK;END;
SIN_RAMP_TO;FROM_NOM;20
STATUS;DISABLE;
TABLE_INFO;END;1
TABLE_INFO;START;25
STATUS;ENABLE;
SIN_RAMP_TO;FROM_ACT;15

```

Figure 19. Extract of the same Lookup Table as in Figure 18, but with the comment column removed, and exported to CSV format

## 7 Temperature Acquisition Hardware and Configuration (Expert Settings)

Every TEC controller channel (TEC-1089-based: 1, TEC-1122-based: 2) features two inputs for resistive thermal devices (RTDs), a primary and an auxiliary input:

- The primary, high resolution 23bit A/D conversion for object temperature measurements is always used.
- The auxiliary, low resolution 12bit A/D conversion for sink temperature measurements is optionally used.

For optimal operation and precision, Meerstetter Engineering recommends to make use of the sink temperature measurement, and to use a Pt1000 probe in 4-wire configuration (see below) for object temperature monitoring.

### 7.1 Object and Sink Temperature Sensors and Input Configurations

The object temperature input (primary, 23bit) is designed for precision measurements. Because of its high resolution, it can also accommodate low  $\Delta R/\Delta T$  probes, such as Pt100, and Pt1000.

The object temperature input is highly configurable because the dedicated ADC has current source functionality ( $I_{DAC}$ ) and a programmable gain amplifier (PGA) buffering the converter core which uses  $R_s$  as a reference.

The ADC is configured to operate in 4-wire mode. If required, 4- to 2-wire conversion jumpers can be set on-board as shown in Figure 1 (TEC-1089-based) or Figure 2 (TEC-1122-based), respectively. However, conversion from 4 to 2 wires off-board, i.e. beyond the connector, allows canceling variability in the connector's contact resistance.

$I_{DAC}$  and PGA gain can be set by Service Software,  $R_s$  is somewhat user-configurable by SMD soldering.

Object Sensor Type	Object T-Range [°C]	Calibration T-Range [°C]	*Extended T-Range [°C]	$R_s$ [kΩ]	$I_{DAC}$ [uA]	PGA Gain	R to °T Conversion
Pt100	-50 to 200	-40 to 220	--	1.5	1'500	8	Internal reference curve according to DIN EN 60751
Pt1000	-50 to 200	-40 to 170	--	3.3	500	2	
NTC 3988 10k	13 to 164	(0), 25, 60	60* to 150*	18	50	1 / 8*	NTC characteristics according to data sheet (user-entered)
NTC 3988 10k	-3 to 130	5, 40, (60)	44* to 120*	39	50	1 / 8*	
NTC 3988 10k	-10 to 50	5, 40, (60)	35* to 110*	56	50	1 / 8*	

Table D. Configuration parameters for selected object temperature probes and ranges using discrete 23bit A/D conversion.  $R_s$  designates the hardware reference resistor,  $I_{DAC}$  and PGA Gain are ADCs software settings. Pt100 and Pt1000 linearization curves according to DIN EN 60751 are stored internally, NTC characteristics (Steinhart-Hart) need to be entered by the user. Pt100 and Pt1000 temperatures are calibrated over the entire range indicated. NTC temperatures are divided into a calibrated, basic range (with PGA gain = 1) and into a range extension (uncalibrated, PGA gain = 8). That extended range offers poorer precision due to NTC characteristics and is marked by \*. Using a different sensor may be required, please refer to the TEC Controller's data sheet.

Possible choices for object temperature input reference resistors  $R_s$  are:  
(0.1%, 5ppm/°C, 100mW, 0805 footprint)

1.5 kΩ	e.g. WELWYN PCF0805-13-1K5-B-T1
3.3 kΩ	e.g. WELWYN PCF0805-13-3K3-B-T1
18 kΩ	e.g. WELWYN PCF0805-13-18K-B-T1
39 kΩ	e.g. WELWYN PCF0805-13-39K-B-T1
56 kΩ	e.g. WELWYN PCF0805-13-56K-B-T1

The sink temperature input (auxiliary, 12bit) can only accommodate NTC probes with high  $\Delta R/\Delta T$ . This input is less configurable and relies on the MCU-integrated 12bit ADC. The circuit's reference resistor  $R_v$  is factory-set to 5.6 kΩ.

Sink Sensor Type	Sink T-Range [°C]	Calibration T-Range [°C]	$R_v$ [kΩ]	NA	NA	R to °T Conversion
NTC 3988 10k	-6 to 150	0, 25, 60	5.6	-	-	NTC characteristics acc. to data sheet

Table E. Reference resistor  $R_v$  for selected sink temperature probe and range using the integrated 12bit ADC.

## 7.2 [optional] Use and Configuration of NTC Temperature Probes

While Pt100 and Pt1000 temperature probe characteristics according to DIN EN 60751 are internally stored, NTC sensor characteristics need to be entered by the user. (This is due to the vast choice of NTC probes available on the market.)

For each NTC temperature acquisition channel decide for three temperatures (lower, middle and upper) spanning the range to be covered. Look up their corresponding resistances in your sensor's data sheet. Three ( $^{\circ}T, R$ ) pairs are needed to model a characteristic temperature-resistance curve (Steinhart-Hart model). This curve will be most precise for small ranges (lower point to upper point) that are centered about a working point / nominal temperature (middle point).

		Actual	New
Lower Point	Temperature [°C]	0	<input type="text"/>
	Resistance [Ω]	32650	<input type="text"/>
Middle Point	Temperature [°C]	25	<input type="text"/>
	Resistance [Ω]	10000	<input type="text"/>
Upper Point	Temperature [°C]	60	<input type="text"/>
	Resistance [Ω]	2488	<input type="text"/>

		Actual	New
Lower Point	Temperature [°C]	0	<input type="text"/>
	Resistance [Ω]	32650	<input type="text"/>
Middle Point	Temperature [°C]	25	<input type="text"/>
	Resistance [Ω]	10000	<input type="text"/>
Upper Point	Temperature [°C]	60	<input type="text"/>
	Resistance [Ω]	2488	<input type="text"/>

Figure 20. NTC Sensor Characteristics fields provided in Tab 'Object Temperature' and Tab 'Sink Temperature'.

Depending on the NTC probe used, and on the hardware / ADC configuration, the usable range of sensor resistance and thus temperature varies. After restart of the TEC controller, the user is informed about the key data of the currently active measurement configuration in corresponding group boxes (see below).

Sensor Type:	Lowest Resistance [Ω]	134
NTC	Highest Resistance [Ω]	17917
	Temperature at Lowest Resistance [°C]	164.3
	Temperature at Highest Resistance [°C]	12.2

Sensor Type:	Lowest Resistance [Ω]	50
NTC	Highest Resistance [Ω]	49781
	Temperature at Lowest Resistance [°C]	214.6
	Temperature at Highest Resistance [°C]	-8.1

Figure 21. NTC-based object and sink temperature acquisition systems' specs calculated on hardware / ADC configurations and NTC characteristics.

### 7.3 Calibration and Hardware Settings (Service Software 'Expert' Tab)

Some features related to temperature acquisition circuitry are accessible through an hidden 'Expert' tab (Sub Tab Temperature Measurement) in the TEC Service Software. In order to make Tab 'Expert' visible, enter the password "expert" into the Login field provided.

The Temperature Measurement settings are related to the subjects covered in this section of the user guide:

- Sensor type choice (object channels only)
- Temperature acquisition circuitry reference resistors  $R_s$  (object channels) and  $R_v$  (sink channels)
- ADC-specific 'Current Source' and 'PGA Gain' settings (object channels only)
- ADC calibration offsets and gains (object and sink channels, factory-calibrated)

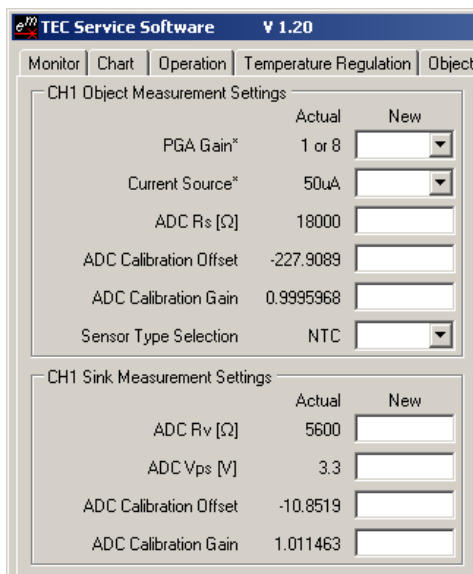

Figure 22. Tab 'Expert' temperature acquisition hardware settings and calibration are device-specific and only accessible from the Service Software when in "Expert" mode. Here, factory calibration settings and NTC configuration data are shown. Please note the '1 or 8' automatic PGA Gain parameter.

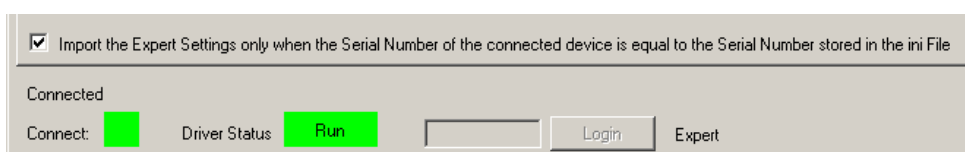

Figure 23. As long as the tick-box in Tab 'Expert' is selected (default), device-specific calibration and temperature acquisition configuration data is not overwritten by importing a general / foreign configuration. However, with a device-specific configuration file, previous calibration status can be restored.

### 7.4 Temperature Probes Assembly

The object and sink temperature probes on cable and plug should be assembled according to below extracts of Figure 1 (TEC-1089-based) or Figure 2 (TEC-1122-based). Compact TEC-1089-based devices use a miniature connector series by JST, larger TEC-1122-based devices use connectors by TE Connectivity. The object temperature 4-wire to 2-wire conversion jumpers are soldered onto the boards and need to be removed for 4-wire configuration.

## 7.5 Temperature Acquisition ADC Circuitry Calibration

The proposed calibration procedure consists of adjusting the slope and offset of the numerical output of an ADC subsystem measuring an analogue input such that it matches a reference behavior. (In the present case, the subsystem consists of the converter, the converter configuration and the resistive network around it.)

Calibration of the ADC subsystem is achieved by measuring two precision resistors of known resistance and comparing the obtained (raw) ADC values with the theoretical (nominal) ones. After acquisition of that raw (unaltered) data, the characteristic  $ADC_{raw}$  output is transformed such that it passes through the two known reference points and becomes  $ADC_{calibrated}$ .

$$ADC_{calibrated} = ADC_{raw} * ADC \text{ Calibration Gain} + ADC \text{ Calibration Offset}$$

The calculated gain ( $a_1$ ) and offset ( $a_0$ ) adjustment values are fed to the TEC ADC subsystem so that the unit is calibrated.

Calibration data is entered into the provided fields in Tab 'Expert' (see Figure 22).

Calibration is device-specific, can be optimized for the RTD type used and should cover a range wider than the planned measurement range.

ADC output calibration for a Pt100 range between 0 and 52°C ( $R_s = 1.5 \text{ k}\Omega$ , PGA gain = 8):  
(0.01%; 0.6ppm/°C; 600mW)

100 $\Omega$ (e.g. VISHAY Y0785100R000T9L)	4'473'924	→ 0.000 ± 0.025 °C
120 $\Omega$ (e.g. VISHAY Y0785120R000T9L)	5'368'709	→ 51.572 ± 0.030 °C

ADC output calibration for a Pt1000 range between 0 and 52°C ( $R_s = 3.3 \text{ k}\Omega$ , PGA gain = 2):  
(0.01%; 0.6ppm/°C; 600mW [1 k $\Omega$ ], 0.01%, 0.2ppm/°C, 300mW [1.2 k $\Omega$ , trimmed])

1000 $\Omega$ (e.g. VISHAY Y07851K00000T9L)	5'084'005	→ 0.000 ± 0.025 °C
1200 $\Omega$ (e.g. VISHAY Y16711K00009W)	6'100'806	→ 51.572 ± 0.030 °C

ADC output calibration for an NTC 3988 10k range between 25 and 60°C ( $R_s = 18 \text{ k}\Omega$ , PGA gain = 1):  
(0.01%; 0.6ppm/°C; 600mW)

10 k $\Omega$ (e.g. VISHAY Y078510K0000T9L)	4'660'338	→ 25.000 ± 0.002 °C
2.5 k $\Omega$ (e.g. VISHAY Y07852K50000T9L)	1'165'084	→ approx. 59.9°C

ADC output calibration for an NTC 3988 10k range between 0 and 40°C ( $R_s = 39 / 56 \text{ k}\Omega$ , PGA gain = 1):  
(0.01%; 0.6ppm/°C; 600mW)

25 k $\Omega$ (e.g. VISHAY Y078525K0000T9L)	5'377'313 / 3'744'914	→ approx. 5.3°C
5 k $\Omega$ (e.g. VISHAY Y07855K00000T9L)	1'075'463 / 748'983	→ approx. 41.6°C

References: RAW ADC upper Value = m      Nominal theoretical value = u  
RAW ADC lower Value = n      Nominal theoretical value = v

$$\text{Calibration Gain } a_1 = \frac{u - v}{m - n} = \frac{Nom(\text{upper} - \text{lower})}{RAW(\text{upper} - \text{lower})}$$

$$\text{Calibration Offset } a_0 = u - a_1 \cdot m = Nom(\text{upper}) - a_1 \cdot RAW(\text{upper})$$

Example: TEC-1089B S/N 002	
Theoretical Data (23bit ADC configured for Pt100: $R_s = 2\text{k}$ , PGA Gain = 16)	
• Upper Nominal Value (120 $\Omega$ ): $v = 2^{23} * 16 * 120 / 2000 = \mathbf{8'053'064}$	51.575°C ±0.01%
• Lower Nominal Value (100 $\Omega$ ): $u = 2^{23} * 16 * 100 / 2000 = \mathbf{6'710'886}$	0.000°C ±0.01%
Measured Data	
• Upper Raw Value (120 $\Omega$ ): $m = \mathbf{8'059'099}$	
• Lower Raw Value (100 $\Omega$ ): $n = \mathbf{6'715'433}$	
→ Applying (1) and (2) yields Calibration Gain $a_1 = 0.998893$ and Calibration Offset $a_0 = 2890$ .	

## 8 Special Functions and Optional Hardware

All these settings are only available if you login with “expert”. Please take care about the “Temperature Measurement” Settings. These Settings are Hardware interdependent.

### 8.1 Optional Display Kit (DPY-1113)

It is possible to attach some types of OLED displays directly to Meerstetter TEC controllers. Basically their firmware supports a 2 Lines x 16 Char OLED display, which is powered and controlled over the X11 connector. A ready-to-use display kit, including cable and connector, is available directly from Meerstetter Engineering. (Please visit the [DPY-1113 product web page for further information](#)). From the TEC Service Software it is possible to choose the information to be displayed. Upon customer request it is also possible to add some other display texts or to control larger displays.

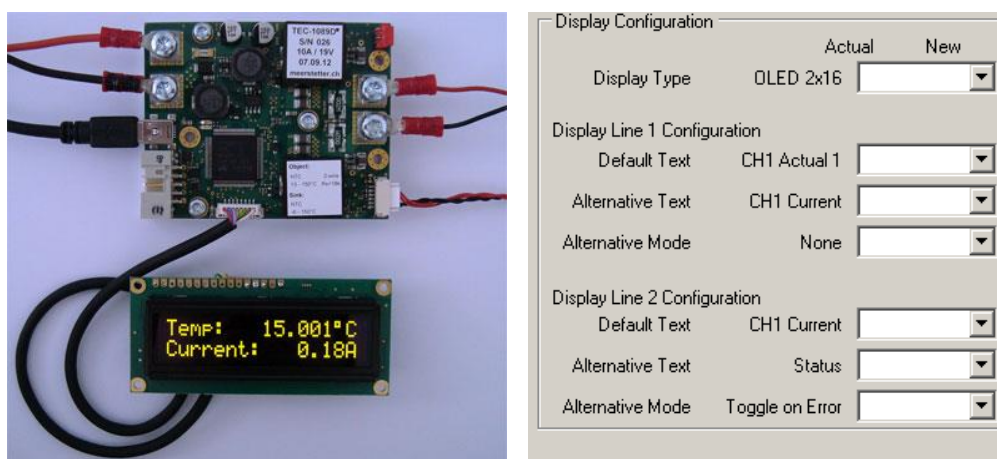

Figure 24. The DPY-1113 display kit can be directly connected to any TEC Family Peltier controller. The information to be displayed is selected from within TEC Service Software.

#### General Display Settings (Expert Tab: Display Configuration):

Setting	Options	Description
Display Type	OFF	Disables the whole feature
	OLED 2x16	A 2x16 Char OLED display is being controlled over the X11 connector
Line 1 and 2 Default Text	Various (see table below)	Selects the information to be displayed by default on the corresponding display line.
Line 1 and 2 Alternative Text	Various (see table below)	Selects the alternative information to be displayed on the corresponding display line.
Line 1 and 2 Alternative Mode	None	No alternative information is displayed
	On Error	If the TEC controller is in Error state, the alternative information is being displayed
	Toggle on Error	If the TEC controller is in Error state, the alternative information is being toggled with the default information.
	Toggle	The default information is toggled with the alternative information.

### Default and Alternative Text Settings (Expert Tab: Display Configuration):

Text Name	Displayed Information	Example	(Parameter Value)*
Startup Text	Device Type; Serial Number Software Version	TEC-1089 S/N 003 SW Version 1.41	---
CHx Actual 1	Object Temperature	Temp: 150.001°C Temp: -49.999°C	CH1: 0; CH2: 11
CHx Actual 2	Object Temperature	Act: 150.001°C Act: -49.999°C	CH1: 1; CH2: 12
CHx Actual 3	Object Temperature	Actual: 150.01°C Actual: -49.99°C	CH1: 2; CH2: 13
CHx CHx: Act	Object Temperature. Recommended to use with TEC-1122	CH1: 150.001°C	CH1: 3; CH2: 14
CHx Nominal 1	Target Temperature	Nominal: 150.0°C	CH1: 4; CH2: 15
CHx Heatsink	Heatsink Temperature	Heatsink: 150°C	CH1: 5; CH2: 16
CHx Act / Sink	Object Temperature and Sink Temperature	150.001° 103.1°	CH1: 6; CH2: 17
CHx Current	Actual Current	Current: -15.03A	CH1: 7; CH2: 18
CHx Voltage	Actual Voltage	Voltage: -15.03V	CH1: 8; CH2: 19
CHx I / U	Actual Current and Actual Voltage	-12.01A -15.01V	CH1: 9; CH2: 20
CHx Act / I	Object Temperature and Actual Current	150.001°C -12.1A	CH1: 10; CH2: 21
Input Voltage	Driver Input Voltage	Input: U= 24.01	22
Status	Driver Status Some main Error Messages	Disabled Running... Temp stable Error: 125, 1 Sink overtemp Sink undertemp Object overtemp Object undertemp TEC-Drv overtemp Sink Meas Error Obj Meas Error Supply Error	23

Upon customer request it is also possible to add some other display texts.

\*These Parameter Values are only relevant if the TEC is being controlled over the bus protocol.

## 8.2 PBC (Platform Bus Connector) RES1 ... RES8 Control Signals

All TEC Models have on the PBC Connector X3 some reserved digital Signals. These Signals can be used as General Purpose or for some predefined functions. The desired function of these digital Signals can be defined in the PBC sub tab under the Expert settings.

The following functions can be selected for every RES1 ... RES8 Signal independent:

Function Name	Description
No Function	The RESx Signal is at high Impedence
Data Interface	The RESx Signal can be controlled as Digital IO from the communication Interface. See the "TEC Controller Communication Protocol 5136" for more details.
TEC OK	The RESx Signal goes high, if the TEC is in Ready or Run status.
CH1 Stable CH2 Stable	The RESx Signal goes high, if the selected TEC Channel is Temperature Stable.
CH1 HW Enable CH2 HW Enable	The RESx Signal is used as Input Signal. These logical Signals can be used as TEC Enable. They need to be selected as Enable Source in Operation Tab. If the input signal is high, the TEC is enabled. If this Function is selected, a weak pull down of 50kOhm is enabled on the processor pin.
CH1 FAN PWM CH2 FAN PWM	The RESx Signal is used as PWM Output for the FAN Control feature. The Output is set to Push Pull. Please refer to the FAN Control chapter for more information. (Can only be selected on RES3 and RES4)
CH1 FAN Tacho CH2 FAN Tacho	The RESx Signal is used as frequency Input for the FAN Control feature. A weak pull up is enabled on this pin. Please refer to the FAN Control chapter for more information.

## 8.3 FAN Control Feature

Up to 2 FANs can be directly connected and controlled by the TEC. The FAN Control Feature is intended to keep the Heat Sink Temperature below a specified temperature, by using the slowest FAN Speed as possible. Please refer to the PBC chapter to configure the FAN Control Signals.

### FAN Requirements:

The FAN Control Feature can only control FANs which have the following features:

- PWM Control Signal Input to control the FAN Speed. The TEC generates a 25kHz PWM Signal from 0 – 100%.
- Frequency Generator Signal Output which represents the rotation speed. The Output should be a Open Collector Output Signal.

Please refer to the TEC Datasheet for the voltage definitions of the logic levels.

## FAN Recommendations:

It is recommended to use a FAN with the same supply voltage as the TEC needs. Usually 12V or 24V, but it is also possible to have a separate Power Supply for the FAN.

Meerstetter Engineering has this feature tested with the following FANs:

Manufacturer	Type	Description	Optimized Settings (1)
DELTA ELECTRONICS	FFB0412VHN-TP03	12V, 2W. 40x40x28mm Recommended FAN for Standard application with less space	0; 10000 0.005; 0.5; 0
NMB-MAT	1611FT-D4W-B86-B50	12V, 11W. 40x40x28mm Small and very strong FAN. (Speed control not perfect, but works)	2000; 20000 0.0005; 2; 0
ORION FANS	OD8038-24HBVXC10A	24V, 13W. 80x80x38mm	1200; 6400 0.005; 1; 0
DELTA ELECTRONICS	QFR1224GHE-SP01	24V, 22.5W. 120x120x38mm	1600; 6000 0.005; 1; 0

On request Meerstetter Engineering can provide some default Settings for the Fans above.

(1): These are optimized settings for the tested fans.

Value Order: [0% Speed]; [100% Speed]; [Kp]; [Ti]; [Td]

## Connecting the FAN to the TEC

If the FAN has the same Supply Voltage as the TEC, it is recommended to connect the FAN GND directly to the TEC GND Connector X2 and the FAN VCC direct to X1. The FAN PWM Input Signal must be connected to RES3 or RES4, because only these two outputs can generate a PWM Signal. The FAN Frequency Output Signal can be connected to one of the RES Signals. Please set the correct Function of the PBC Signals. See "8.2 PBC (Platform Bus Connector) RES1 ... RES8 Control Signals"

If you use a separate Power Supply for the FAN, please make sure that the two GND Signals of the two separate Power Supplies are connected together.

## Control Function Description:

The feature consists of two PID controllers.

The first PID controller controls the temperature. As result of the Temperature Controller we get a value from 0% required cooling power to 100% required cooling power. Mostly a P Control is good enough. We recommend a Kp of 30% / °C. This means if the Target Temperature is set to 40°C the FAN will have 0 Speed at 40°C and about 100% Speed at 43°C.

The required cooling power is then converted into a nominal FAN speed. For Example the user has set a minimum FAN Speed of 1000 rpm and a maximum FAN Speed auf 11000 rpm. A required cooling power of 50% is converted into a nominal FAN speed of 6000 rpm.

The second PID controller controls the speed of the FAN. The PWM Output signal is being varied till the nominal FAN speed is being reached.

It is Recommended to first setup the FAN Speed Controller without Temperature regulation. This can be done by setting a high Target Temperature and a very high 100% Speed rpm Value. Then the 0% Speed rpm Value can be used to set a fixed rotation speed. The FAN should reach the Nominal speed as fast as possible.

#### CHx FAN Control Enable

Parameter Name	Options and Description
FAN Control Enable	<ul style="list-style-type: none"> <li>• Disabled.</li> <li>• Enabled: The FAN Control Feature is enabled. This means also that the FAN surveillance is enabled. Please refer to the Error Description for the Errors 175, 176.</li> </ul>

#### CHx FAN Temperature Controller

Parameter Name	Options and Description
Actual Temperature Source	<ul style="list-style-type: none"> <li>• Sink: The Actual Temperature for the FAN Temperature Controller is being taken from the Sink Temperature</li> <li>• Object: The Actual Temperature for the FAN Temperature Controller is being taken from the Object Temperature</li> </ul>
Target Temperature	Target Temperature for the FAN Temperature Controller. Mostly this is the temperature which the Heat Sink not should exceed too much.
Kp, Ti, Td	PID Controller Parameters for the Temperature Controller. Defines how aggressive the temperature should kept at the Target Temperature.

#### CHx FAN Speed Controller

Parameter Name	Options and Description
0% Speed	Minimum rotation Speed
100% Speed	Maximum rotation Speed
Kp, Ti, Td	PID Controller Parameters for the FAN Speed Controller.

## 8.4 Misc Expert Settings

### CHx Actual Object Temperature Source Selection

Setting	Description
Internal	Default Setting. The Onboard Temperature Measurement circuit is being used.
External	The Temperature can be feed over a Data Interface.

For further information please check: the Document "TEC Controller Communication Protocol 5136".

### Parameter System Save to Flash Configuration (Save Data to Flash)

Setting	Description
Enabled	Default Setting. Every time when a Parameter has been changed a delay timer of 2s is being started. If this delay timer has expired all data is being saved to the non-volatile flash.
Disabled	Saving to the non-volatile flash is disabled. Can be useful to control the TEC over a bus system, where parameters are changed regularly to prevent the flash from early failure.

For further information please check: the Document "TEC Controller Communication Protocol 5136".

## Appendix 1 Peltier Controller Factory Settings

**Tab3 'Operation'**

(valid for all TEC controller models)

CHx Output Stage Control Input Selection		'Static Current/Voltage'
CHx Output Stage Enable		'Static OFF'
CHx Output Stage 'Static Current/Voltage'...	Set Current	1 A
	Set Voltage	10 V
CHx Output Stage Limits	Current Limitation	10 A
	Voltage Limitation	19 V
	Current Error Threshold	12 A
	Voltage Error Threshold	22.8 V
General Operating Mode		'Single (Independent)'
Device Address	Device Address	2
RS485 Channel 1 Settings	Channel Baud Rate	57600
	Response Delay	0 $\mu$ s

**Tab4 'Temperature Control'**

(valid for selected TEC controller models)

CHx Nominal Temperature	Target Object Temp	25°C
	Coarse Temp Ramp	1°C/s
	Proximity Width	1°C
CHx Temperature Controller PID Values	Kp	10%/°C
	Ti	300 s
	Td	0 s
CHx Modelization for Thermal Power Regulation		'Peltier, Full Control'
CHx Peltier Characteristics	Maximal Current	15 A
	Maximal Voltage	15.4 V
	Cooling Capacity $Q_{max}$	130 W
	Delta Temp $dT_{max}$	68°C
	Positive Current is	Heating
CHx Resistor Characteristics	Resistance	1.65 $\Omega$
	Maximal Current	10 A

**Tab5 'Object Temperature'**

(case of NTC 3988 10k @ object)

CHx Object Measurement Settings	Temperature Offset	0
	Temperature Gain	1
CHx Actual Object Temperature Error Limits	Lower Error Threshold	13°C
	Upper Error Threshold	65°C
	Max Temp Change	5°C/s
CHx Object NTC Sensor Characteristics	Lower Point Temperature	0°C
	Lower Point Resistance	32650 $\Omega$
	Middle Point Temperature	25°C
	Middle Point Resistance.	10000 $\Omega$
	Upper Point Temperature	60°C
	Upper Point Resistance	2488 $\Omega$
CHx Object Temp. Stability Indicator Settings	Temperature Window	1°C
	Min Time in Window	10 s

**Tab6 'Sink Temperature'**

(case of NTC 3988 10k @ sink)

CHx Sink Measurement Settings	Temperature Offset	0
	Temperature Gain	1
CHx Actual Sink Temperature Error Limits	Lower Error Threshold	5°C
	Upper Error Threshold	70°C
	Max Temp Change	5°C/s
CHx Sink NTC Sensor Characteristics	Lower Point Temperature	0°C
	Lower Point Resistance	32650 Ω
	Middle Point Temperature	25°C
	Middle Point Resistance.	10000 Ω
	Upper Point Temperature	60°C
	Upper Point Resistance	2488 Ω
CHx Sink Temperature Source Selection	Sink Temperature Selection	'Fixed Value'
	Fixed Temperature	25°C

**Tab9 'Expert'****Sub Tab Temperature Measurement**

(case of NTC 3988 10k @object)

CHx Object Measurement Settings	PGA Gain	1 or 8 (autogain)
	Current Source	50 μA
	ADC Rs	18000 Ω
	ADC Calibration Offset	offset/intercept 'a <sub>0</sub> ', device-specific
	ADC Calibration Gain	gain/slope 'a <sub>1</sub> ', device-specific
	Sensor Type Selection	NTC
CHx Sink Measurement Settings	ADC Rv	5600 Ω
	ADC Vps	3.3 V
	ADC Calibration Offset	offset/intercept 'a <sub>0</sub> ', device-specific
	ADC Calibration Gain	gain/slope 'a <sub>1</sub> ', device-specific

**Sub Tab Display**

Display Configuration	Display Type	OFF
Line 1	Default Text	CH1 Actual 1
Line 1	Alternative Text	CH1 Actual 1
Line 1	Alternative Mode	None
Line 2	Default Text	CH1 Actual 1
Line 2	Alternative Text	CH1 Actual 1
Line 2	Alternative Mode	None

**Sub Tab PCB**

PBC Configuration (RES1 ... RES8)	PBC RES1	No Function
	PBC RES2	No Function
	PBC RES3	No Function
	PBC RES4	No Function
	PBC RES5	No Function
	PBC RES6	No Function
	PBC RES7	No Function
	PBC RES8	No Function

**Sub Tab FAN**

CHx FAN Control Enable	FAN Control Enable	Disabled
CHx FAN Temperature Controller	Actual Temperature Source	Sink
	Target Temperature	40
	Kp	30
	Ti	120
	Td	0
CHx FAN Speed Controller	0% Speed	0
	100% Speed	10000
	Kp	0.0005
	Ti	2
	Td	0
FAN General Settings	FAN PWM Frequency	25kHz

**Sub Tab Misc**

CHx Actual Object Temperature Source Selection	Source Selection	Internal
Parameter System Save to Flash Configuration	Save Data to Flash	Enabled

## Appendix 2 TEC Controller Status LEDs and Error Codes

### System Status

TEC-Family devices feature two status LEDs. In normal operation, the green LED is blinking.

In the case of any error occurring, the TEC controller enters an error status and the red LED is lit. Power circuitry (output stage) is immediately deactivated for safety reasons. Control, monitoring and communication circuitry remains active. In case of software / configuration errors (*i.e.* not hardware faults), parameter can be reconfigured on the fly. The TEC controller needs to be software-reset or power-cycled to clear the error status.

Green LED	Red LED	Signification
Blinking slowly	-	'Ready' status (no errors). TEC output stage disabled
Blinking fast	-	'Run' status (no errors). TEC output stage active
-	Static ON	'Error' status. TEC output stage disabled
Static ON	Static ON	'Bootloader' status

Table F. Status LED reference chart

When a TEC controller is configured / operated by the Service Software, its status is displayed in a color code at the bottom of the window.

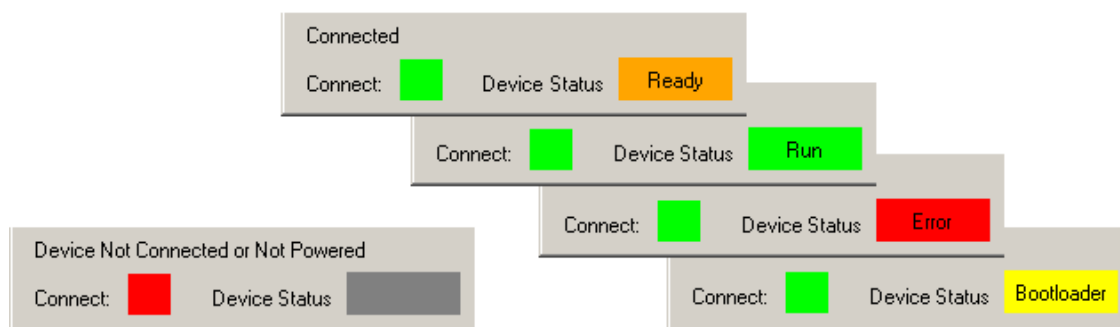

Figure 25. TEC Service Software color codes for connection and device status

## Error Numbers, Instances and Parameters

- Error Numbers from 1 through 99 designate error conditions that are universal across the whole range of Meerstetter advanced TEC controllers and laser diode drivers. Error numbers starting from 100 designate conditions that are specific to TEC-Family devices (see tables below).
- Error Instance typically designates the channel involved. For TEC-1089-based devices it is 1. For TEC-1122-based devices, it can be 1 or 2.
- Error Parameters are additional information helping the software engineers at Meerstetter Engineering in the processes of error diagnosis or remote debugging.

### Error Numbers 1 - 99 (Universal, for TEC-Family and LDD-Family devices)

#	Code	Description	Error Condition
1	STM32HANDLER_NMI		
2	STM32HANDLER_HARD_FAULT		
3	STM32HANDLER_MEM_MANAGER		
4	STM32HANDLER_BUS_FAULT		
5	STM32HANDLER_USAGE_FAULT		
6	STM32HANDLER_SVC	MCU system malfunction	
7	STM32HANDLER_DEBUG_MON		
8	STM32HANDLER_PEND_SV		
9	SYS_NOT_HANDLED_INT		
10	WWDG_RESET_OCCURRED		

*Table G. Processor Errors*

#	Code	Description	Error Condition
11	EMERGENCY_STOP	Emergency stop pressed	
12	HMI_FREE_TIMEOUT	HMI regularly sends 'free' signals to all rack-internal devices such that they are allowed to activate their output stages (if enabled)	No signal received for more than one second

*Table H. HMI Errors (when TEC is mounted into an LTR-1200 rack enclosure)*

#	Code	Description	Error, Remedy
20	PARAMETER_READ	Internal parameter system malfunction	
21	PARAMETER_WRITE		
22	PAR_LOAD_CRC	Parameter set corrupt	Configuration flash empty or defect (Remedy cf. error #23)
23	PAR_LOAD_PAR_VERSION	Parameter set incompatible with current firmware version	Load .ini file saved prior to FW update, or Default.ini
24	UNKNOWN_DEVICE_TYPE	Firmware does not recognize valid device	
25	WRONG_INSTANCE	Internal parameter system malfunction	Access to a non-existing instance
26	LIMIT_SET_GET	Internal limit system malfunction	
27	WRONG_TYPE	Parameter write or read wrong datatype function used	
28	OUT_OF_RANGE	Parameter write value out of range	
29	PAR_FROM_ISR	Parameter save to flash called from interrupt	

Table I. Parameter Errors

#	Code	Description	Error Condition
30	UNDERVOL_PWR	Input voltage net out of range	< 10.5 V
31	OVERVOL_PWR		> 27 V
32	UNDERVOL_10V	Internal 10V power net out of range	< 9 V
33	OVERVOL_10V		> 11 V
36	UNDERVOL_33V	Internal 3.3V power net out of range	< 3.1 V
37	OVERVOL_33V		> 3.5 V

Table J. Power Supply Errors

#	Code	Description	Error Condition
50	FLASH_WRITE_TIMEOUT	On-board flash failure	Write Timeout
51	FLASH_ERASE_TIMEOUT		Erase Timeout
52	FLASH_INVALID_ADDR		Invalid Address

Table K. Flash Errors

#	Code	Description	Error Condition
53	USART_TX_FIFO_OVER	Send buffer overflow error	

Table L. Com (UART) Error

#	Code	Description	Error Condition
60	OVERTEMPERATURE	Device running too hot (@ base plate)	> 60 °C
61	EXT_HW_TEST_FAILURE	Communication error with I/O hardware during factory test	

Table M. Temperature and External Hardware Errors

## Error Numbers 100 - ... (Specific, for TEC-Family devices)

#	Code	Description	Error, Remedy
100	OVERCUR_OUTP_POS	Overcurrent, Driver CHx OUT+	> 'Current Error Threshold'
101	OVERCUR_OUTP_NEG		
102	OVERCUR_OUTN_POS	Overcurrent, Driver CHx OUT-	> 'Current Error Threshold'
103	OVERCUR_OUTN_NEG		
104	OVERVOL_OUTP	Overvoltage, Driver CHx OUT+	> 'Voltage Error Threshold'
105	OVERVOL_OUTN	Overvoltage, Driver CHx OUT-	
106	ERROR_SUPPLY_RCD	Residual current too high	Leakage current > 2A, Check output cables for insulation defects
107	GLOBAL_OVERCUR_WATCHDOG	Overall current monitoring, triggers fast switchoff (within 10 $\mu$ s)	TEC-1089, TEC-1122: +/-14 A TEC-1090, TEC-1123: +/-22 A
108	PID_LIMIT	PWM saturation error (e.g. saturation reached more than 10 consecutive times)	Typ. PWM saturation time > 1ms (10x100us), Check input current is sufficient and $V_{out}$ not set too close to $V_{in}$
109	OVER_SYMMETRY	Currents through CHx Drivers OUT+ and OUT- too unequal	Leak current at output, faulty current detection
110	ERROR_OUT_POWER_LIMITATION	TEC Power Output Error: Allowed total output power reached	Reduce Output Power

Table N. TEC Power Output Errors

#	Code	Description	Error Condition
120	IxA_OFFSET_HIGH	Offset during initialization of current monitor out of range, Driver CHx OUT+	TEC-1089, TEC-1122: +/-500 mA
121	IxA_OFFSET_LOW		
122	IxB_OFFSET_HIGH	Offset during initialization of current monitor out of range, Driver CHx OUT-	TEC-1090, TEC-1123: +/-1000 mA
123	IxB_OFFSET_LOW		

Table O. Current Measurement Errors

#	Code	Description	Error Condition
130	TMEAS_INIT_NOT_READY	External ADC initialization took too long	Timeout: 150 ms
131	TMEAS_INIT_WRONG_READY	External ADC 'Ready' flag missing during initialization	
132	TMEAS_INIT_AVDD	External ADC supply voltage out of range	-5% < AVDD < +5%
133	TMEAS_AD_VALUE_UNDER	23bit ADC raw value below safety margin	< 500000 (6%)
134	TMEAS_AD_VALUE_OVER	23bit ADC raw value above safety margin	> 8350000 (99.5%)
137	TMEAS_TEMP_UNDER	Measured object temperature out of permitted range	< 'Lower Error Threshold'
138	TMEAS_TEMP_OVER		> 'Upper Error Threshold'
139	TMEAS_RAMP_ERROR	Change in measured object temperature too fast (outpacing thermal inertia)	> 'Max Temp Change'

Table P. Object Temperature Measurement Errors

#	Code	Description	Error Condition
140	TSINK_AD_VALUE_UNDER	12bit ADC raw value below safety margin	< 40 (1%)
141	TSINK_AD_VALUE_OVER	12bit ADC raw value above safety margin	> 4050 (99%)
142	TSINK_TEMP_UNDER	Measured sink temperature out of permitted range	< 'Lower Error Threshold'
143	TSINK_TEMP_OVER		> 'Upper Error Threshold'
144	TSINK_RAMP_ERROR	Change in measured sink temperature too fast (outpacing thermal inertia)	> 'Max Temp Change'

Table Q. Sink Temperature Measurement Errors

#	Code	Description	Error Condition
170	ATUNE_NO_PROGRESS	Progress Error	Less than 3% of progress advancement in 5 minutes
171	ATUNE_TEMP_DEVIATION	Auto tuning failures at three consecutive attempts	More than 20% discrepancy in temperature
172	ATUNE_PERIOD_DEVIATION	Auto tuning failures at three consecutive attempts	More than 20% discrepancy in waveform period

Table R. Auto Tune Errors

#	Code	Description	Error Condition
175	ERROR_FAN_CONTROL_LIMIT	The FAN does not reach the desired rotation speed.	FAN PWM Signal is 100% and the reached Speed is < 60% of the nominal speed while 12s
176	ERROR_FAN_BLOCKED	The FAN does not rotate	FAN Speed = 0 and PWM Level > 10% while 10s

Table S. FAN Control Errors

#	Code	Description	Error Condition
180	LUT_UNKNOWN_INSTR	Unknown Instruction	
181	LUT_TABLE_INFO_MISUSE	Misuse of an Instruction	

Table T. Lookup Table Errors